

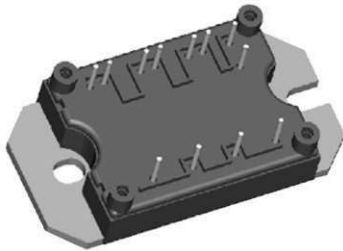

“Half Bridge” IGBT MTP (Warp 2 Speed IGBT), 70 A

MTP

PRIMARY CHARACTERISTICS	
V_{CES}	600 V
$V_{CE(on)}$ typical at $V_{GE} = 15$ V	2.1 V
I_C at $T_C = 78$ °C	70 A
Speed	30 kHz to 150 kHz
Package	MTP
Circuit configuration	Half bridge

FEATURES

- NPT warp 2 speed IGBT technology with positive temperature coefficient
- HEXFRED® antiparallel diodes with ultrasoft reverse recovery
- SMD thermistor (NTC)
- Al_2O_3 BDC
- Very low stray inductance design for high speed operation
- UL approved file E78996 
- Designed and qualified for industrial level
- Material categorization: for definitions of compliance please see www.vishay.com/doc?99912

RoHS
COMPLIANT

BENEFITS

- Optimized for welding, UPS and SMPS applications
- Lower conduction losses and switching losses
- Low EMI, requires less snubbing
- Direct mounting to heatsink
- PCB solderable terminals

ABSOLUTE MAXIMUM RATINGS				
PARAMETER	SYMBOL	TEST CONDITIONS	MAX.	UNITS
Collector to emitter voltage	V_{CES}		600	V
Continuous collector current	I_C	$T_C = 25$ °C	100	A
		$T_C = 78$ °C	70	
Pulsed collector current	I_{CM}		300	
Peak switching current	I_{LM}		300	
Diode continuous forward current	I_F	$T_C = 78$ °C	53	
Peak diode forward current	I_{FM}		200	
Gate to emitter voltage	V_{GE}		± 20	V
RMS isolation voltage	V_{ISOL}	Any terminal to case, $t = 1$ min	2500	
Maximum power dissipation, IGBT	P_D	$T_C = 25$ °C	347	W
		$T_C = 100$ °C	139	

ELECTRICAL SPECIFICATIONS ($T_J = 25$ °C unless otherwise specified)						
PARAMETER	SYMBOL	TEST CONDITIONS	MIN.	TYP.	MAX.	UNITS
Collector to emitter breakdown voltage	$V_{(BR)CES}$	$V_{GE} = 0$ V, $I_C = 500$ μ A	600	-	-	V
Collector to emitter voltage	$V_{CE(on)}$	$V_{GE} = 15$ V, $I_C = 70$ A	-	2.1	2.4	V
		$V_{GE} = 15$ V, $I_C = 140$ A	-	2.8	3.4	
		$V_{GE} = 15$ V, $I_C = 70$ A, $T_J = 150$ °C	-	2.7	3	
Gate threshold voltage	$V_{GE(th)}$	$I_C = 0.5$ mA	3	-	6	
Collector to emitter leaking current	I_{CES}	$V_{GE} = 0$ V, $I_C = 600$ V	-	-	0.7	mA
		$V_{GE} = 0$ V, $I_C = 600$ V, $T_J = 150$ °C	-	-	10	
Gate to emitter leakage current	I_{GES}	$V_{GE} = \pm 20$ V	-	-	± 250	nA



SWITCHING CHARACTERISTICS (T _J = 25 °C unless otherwise specified)						
PARAMETER	SYMBOL	TEST CONDITIONS	MIN.	TYP.	MAX.	UNITS
Total gate charge (turn-on)	Q _g	I _C = 70 A	-	460	690	nC
Gate to emitter charge (turn-on)	Q _{ge}	V _{CC} = 480 V	-	160	250	
Gate to collector charge (turn-on)	Q _{gc}	V _{GE} = 15 V	-	70	130	
Turn-on switching loss	E _{on}	R _g = 10 Ω	-	1.1	-	mJ
Turn-off switching loss	E _{off}	I _C = 70 A, V _{CC} = 480 V, V _{GE} = 15 V, L = 200 μH	-	0.9	-	
Total switching loss	E _{ts}	energy losses include tail and diode reverse recovery, T _J = 25 °C	-	2	-	
Turn-on switching loss	E _{on}	R _g = 10 Ω	-	1.27	-	
Turn-off switching loss	E _{off}	I _C = 70 A, V _{CC} = 480 V, V _{GE} = 15 V, L = 200 μH	-	1.13	-	ns
Total switching loss	E _{ts}	energy losses include tail and diode reverse recovery, T _J = 150 °C	-	2.4	-	
Turn-on delay time	t _{d(on)}	R _g = 10 Ω	-	314	-	
Rise time	t _r	I _C = 70 A, V _{CC} = 480 V, V _{GE} = 15 V, L = 200 μH	-	49	-	
Turn-off delay time	t _{d(off)}	energy losses include tail and diode reverse recovery	-	308	-	ns
Fail time	t _f		-	68	-	
Turn-on delay time	t _{d(on)}	R _g = 10 Ω	-	312	-	
Rise time	t _r	I _C = 70 A, V _{CC} = 480 V, V _{GE} = 15 V, L = 200 μH	-	50	-	
Turn-off delay time	t _{d(off)}	energy losses include tail and diode reverse recovery, T _J = 150 °C	-	320	-	pF
Fail time	t _f		-	78	-	
Input capacitance	C _{ies}	V _{GE} = 0 V	-	8000	-	
Output capacitance	C _{oes}	V _{CC} = 30 V	-	790	-	
Reverse transfer capacitance	C _{res}	f = 1.0 MHz	-	110	-	
Reverse BIAS safe operating area	RBSOA	T _J = 150 °C, I _C = 300 A V _{CC} = 400 V, V _P = 600 V R _g = 22 Ω, V _{GE} = + 15 V to 0 V	Fullsquare			

THERMISTOR SPECIFICATIONS						
PARAMETER	SYMBOL	TEST CONDITIONS	MIN.	TYP.	MAX.	UNITS
Resistance	R ₀ ⁽¹⁾	T ₀ = 25 °C	-	30	-	kΩ
Sensitivity index of the thermistor material	β ⁽¹⁾⁽²⁾	T ₀ = 25 °C T ₁ = 85 °C	-	4000	-	K

Notes

(1) T₀, T₁ are thermistor's temperatures

(2) $\frac{R_0}{R_1} = \exp\left[\beta\left(\frac{1}{T_0} - \frac{1}{T_1}\right)\right]$, temperature in Kelvin

DIODE SPECIFICATIONS (T _J = 25 °C unless otherwise specified)						
PARAMETER	SYMBOL	TEST CONDITIONS	MIN.	TYP.	MAX.	UNITS
Diode forward voltage drop	V _{FM}	I _C = 70 A, V _{GE} = 0 V	-	1.64	2.1	V
		I _C = 140 A, V _{GE} = 0 V	-	2.1	2.4	
		I _C = 70 A, V _{GE} = 0 V, T _J = 150 °C	-	1.69	1.9	
Diode reverse recovery time	t _{rr}	V _{CC} = 200 V, I _C = 70 A dl/dt = 200 A/μs	-	96	126	ns
Diode peak reverse current	I _{rr}		-	9.4	12.8	A
Diode recovery charge	Q _{rr}		-	440	750	nC
Diode reverse recovery time	t _{rr}	V _{CC} = 200 V, I _C = 70 A dl/dt = 200 A/μs T _J = 125 °C	-	140	194	ns
Diode peak reverse current	I _{rr}		-	14	19	A
Diode recovery charge	Q _{rr}		-	950	1700	nC



THERMAL AND MECHANICAL SPECIFICATIONS							
PARAMETER		SYMBOL	TEST CONDITIONS	MIN.	TYP.	MAX.	UNITS
Operating junction temperature range	IGBT, Diode	T_J		-40	-	150	°C
	Thermistor			-40	-	125	
Storage temperature range		T_{Stg}		-40	-	125	
Junction to case	IGBT	R_{thJC}		-	-	0.36	°C/W
	Diode			-	-	0.8	
Case to sink per module		R_{thCS}	Heatsink compound thermal conductivity = 1 W/mK	-	0.06	-	
Mounting torque to heatsink			A mounting compound is recommended and the torque should be checked after 3 hours to allow for the spread of the compound. Lubricated threads.	3 ± 10 %			Nm
Weight				66			g

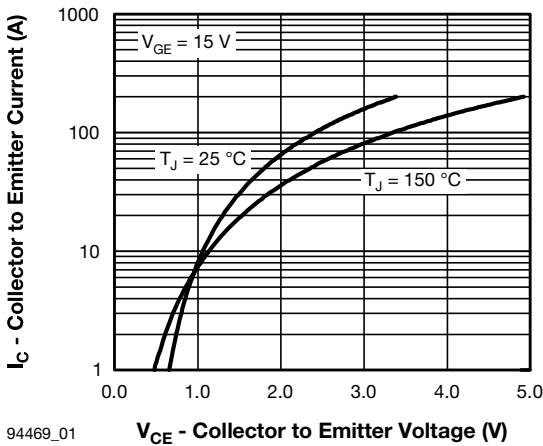

Fig. 1 - Typical Output Characteristics

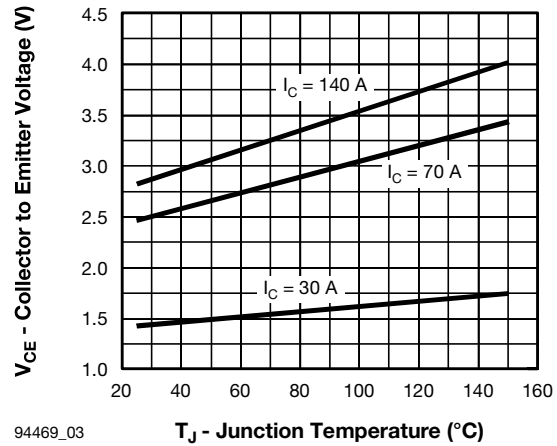

Fig. 3 - Typical Collector to Emitter Voltage vs. Junction Temperature

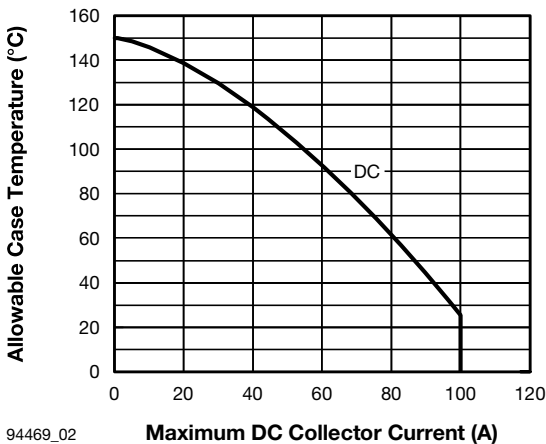

Fig. 2 - Maximum Collector Current vs. Case Temperature

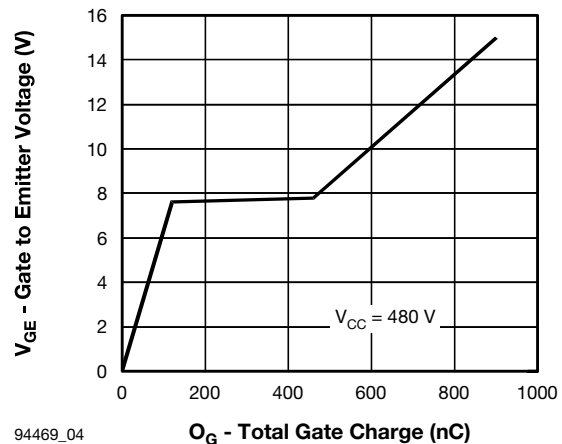
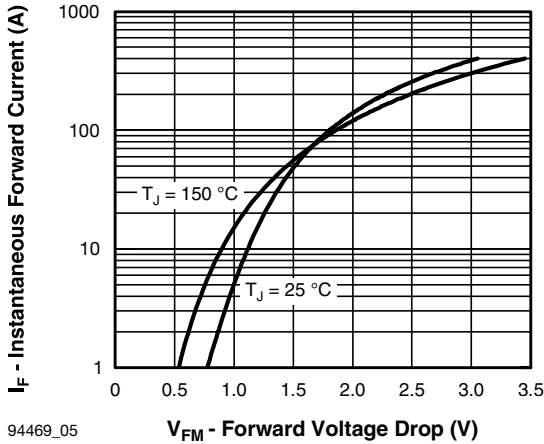
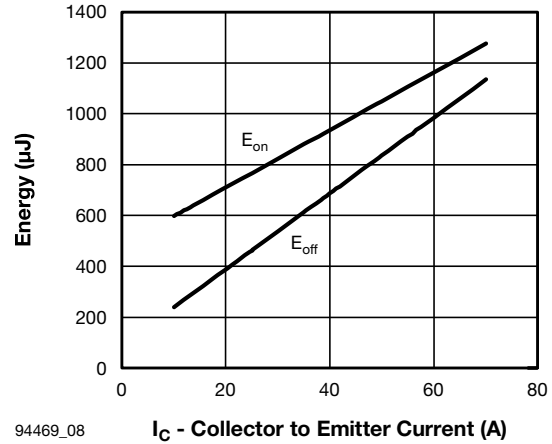

Fig. 4 - Typical Gate Charge vs. Gate to Emitter Voltage



94469_05

Fig. 5 - Maximum Forward Voltage Drop vs. Instantaneous Forward Current



94469_08

Fig. 8 - Typical Energy Losses vs. I_C ($T_J = 150\text{ }^\circ\text{C}$)

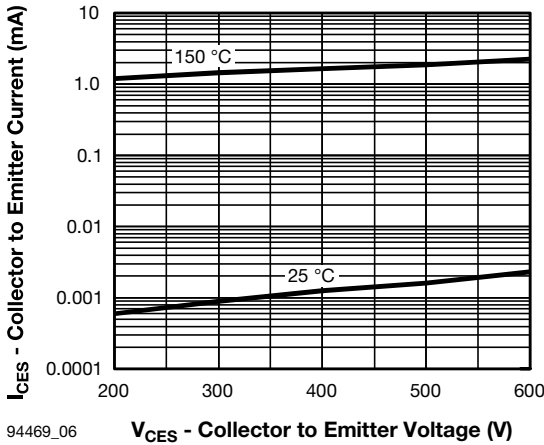

94469_06

Fig. 6 - Typical Zero Gate Voltage Collector Current

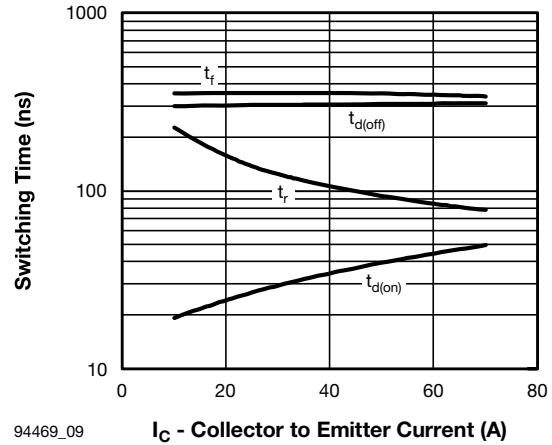

94469_09

Fig. 9 - Switching Time vs. I_C

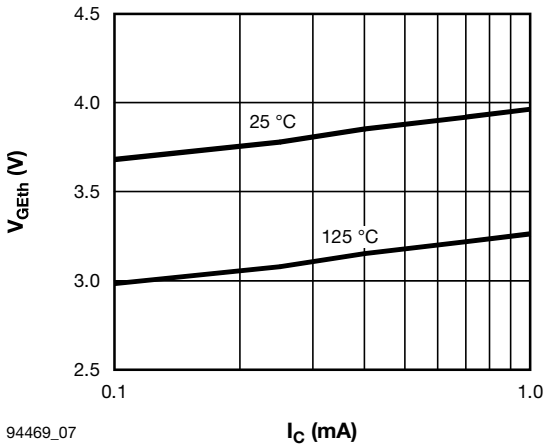

94469_07

Fig. 7 - Typical Gate Threshold Voltage

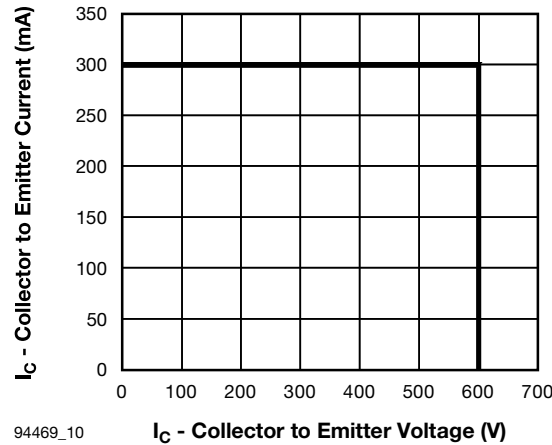

94469_10

Fig. 10 - Reverse BIAS SOA, $T_J = 150\text{ }^\circ\text{C}$

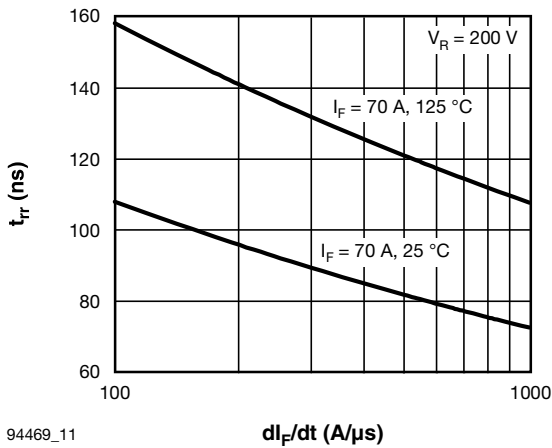

94469_11

Fig. 11 - Typical Reverse Recovery Time vs. di_F/dt

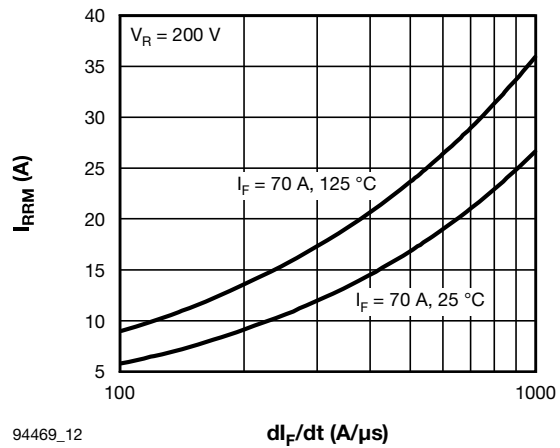

94469_12

Fig. 12 - Typical Reverse Recovery Current vs. di_F/dt

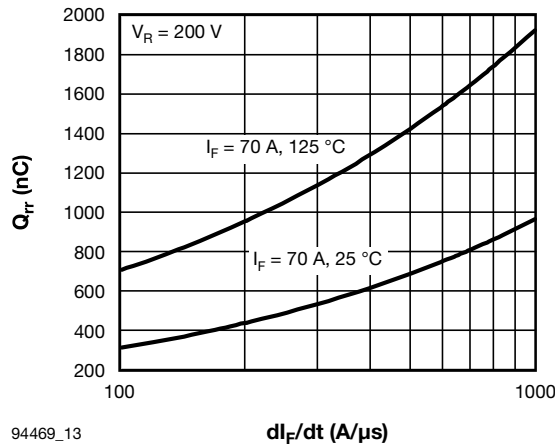

94469_13

Fig. 13 - Typical Stored Charge vs. di_F/dt

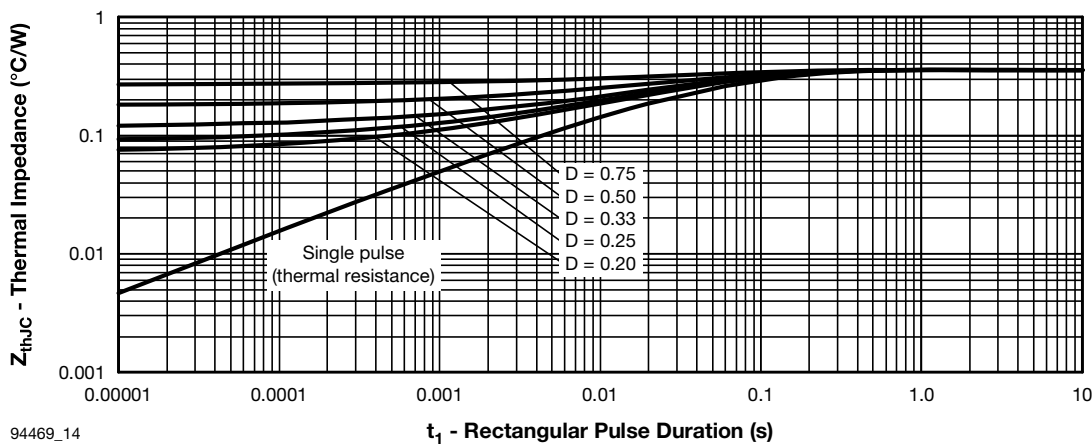

94469_14

Fig. 14 - Maximum Thermal Impedance Z_{thJC} Characteristics (IGBT)

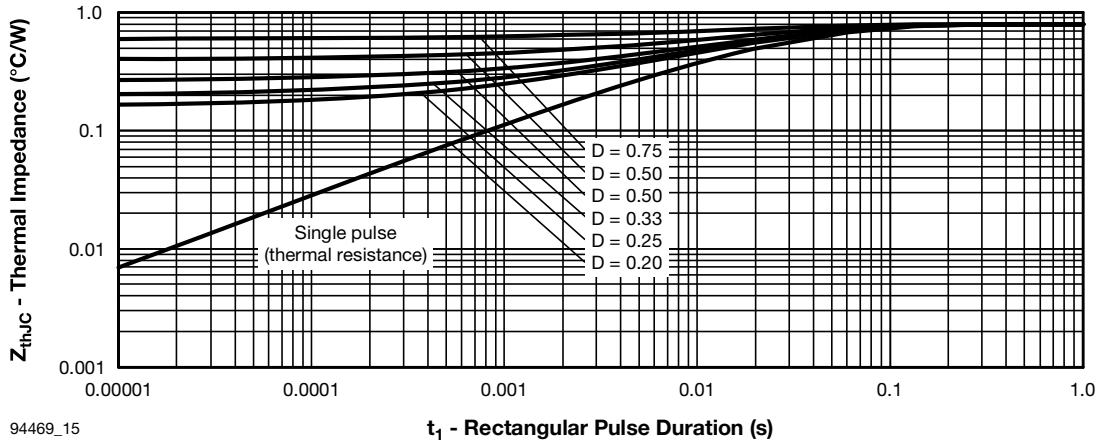

Fig. 15 - Maximum Thermal Impedance Z_{thJC} Characteristics (Diode)

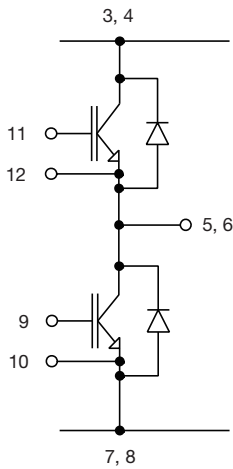

Fig. 16 - Electrical Diagram

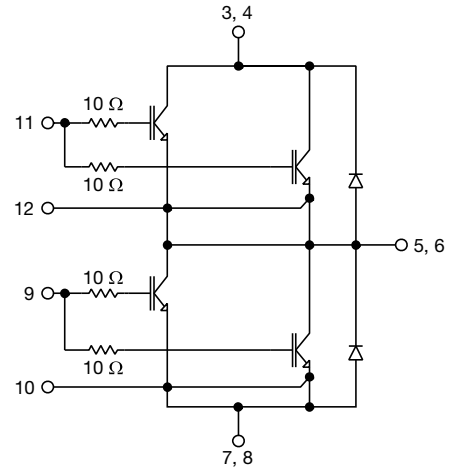
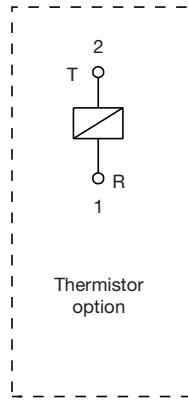

Fig. 17 - Functional Diagram

ORDERING INFORMATION TABLE

Device code	VS-	70	MT	060	W	H	T	A	PbF
	①	②	③	④	⑤	⑥	⑦	⑧	⑨

- 1** - Vishay Semiconductors product
- 2** - Current rating (70 = 70 A)
- 3** - Essential part number
- 4** - Voltage rating (060 = 600 V)
- 5** - Speed/type (W = warp IGBT)
- 6** - Circuit configuration (H = half bridge)
- 7** - T = thermistor
- 8** - A = Al₂O₃ DBC substrate
- 9** - Lead (Pb)-free



CIRCUIT CONFIGURATION

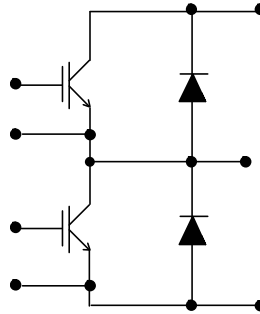

LINKS TO RELATED DOCUMENTS

Dimensions	www.vishay.com/doc?95175
------------	--



MTP

DIMENSIONS in millimeters

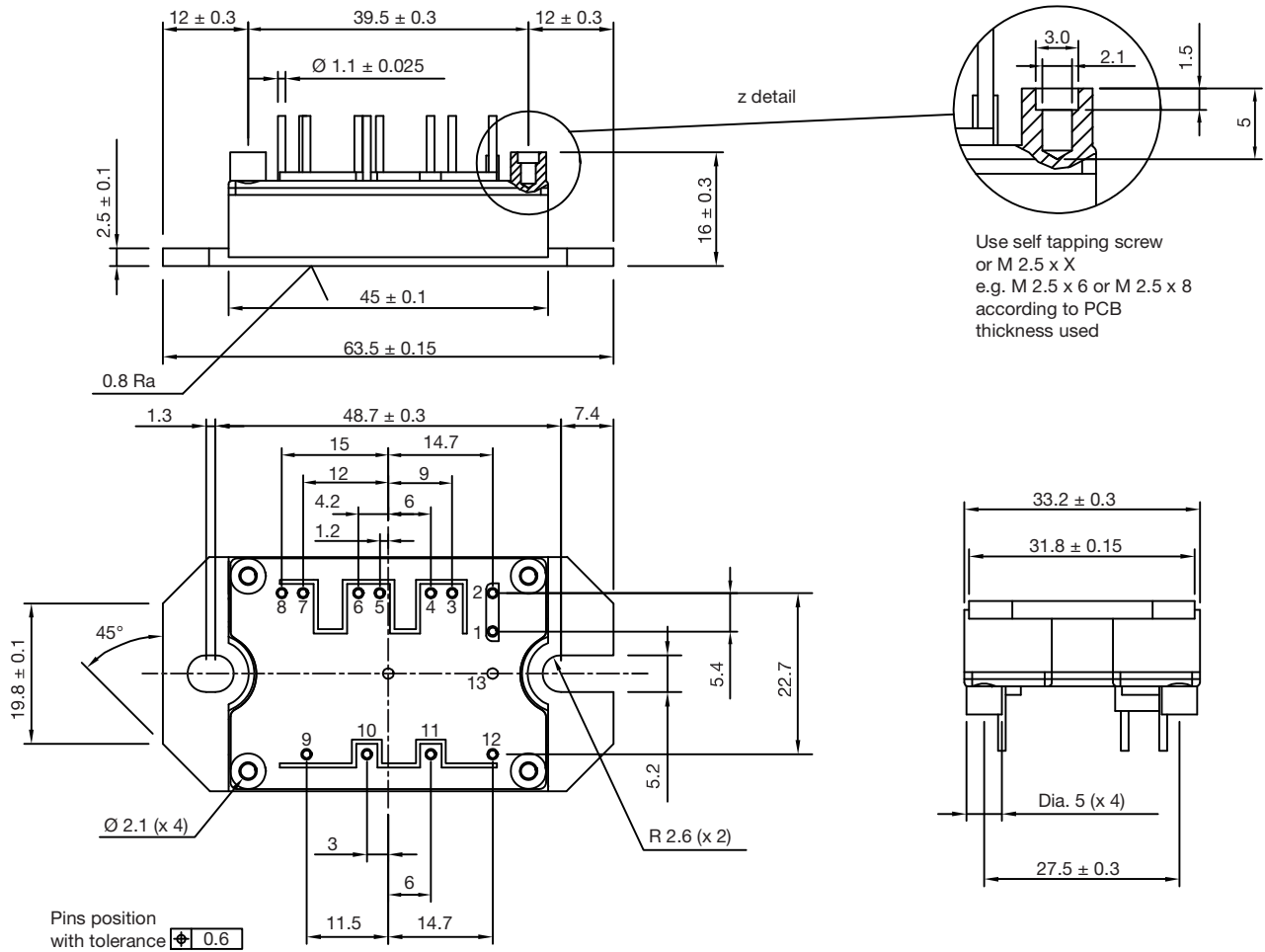

Use self tapping screw or M 2.5 x X e.g. M 2.5 x 6 or M 2.5 x 8 according to PCB thickness used

Note

- Unused terminals are not assembled in the package



Disclaimer

ALL PRODUCT, PRODUCT SPECIFICATIONS AND DATA ARE SUBJECT TO CHANGE WITHOUT NOTICE TO IMPROVE RELIABILITY, FUNCTION OR DESIGN OR OTHERWISE.

Vishay Intertechnology, Inc., its affiliates, agents, and employees, and all persons acting on its or their behalf (collectively, "Vishay"), disclaim any and all liability for any errors, inaccuracies or incompleteness contained in any datasheet or in any other disclosure relating to any product.

Vishay makes no warranty, representation or guarantee regarding the suitability of the products for any particular purpose or the continuing production of any product. To the maximum extent permitted by applicable law, Vishay disclaims (i) any and all liability arising out of the application or use of any product, (ii) any and all liability, including without limitation special, consequential or incidental damages, and (iii) any and all implied warranties, including warranties of fitness for particular purpose, non-infringement and merchantability.

Statements regarding the suitability of products for certain types of applications are based on Vishay's knowledge of typical requirements that are often placed on Vishay products in generic applications. Such statements are not binding statements about the suitability of products for a particular application. It is the customer's responsibility to validate that a particular product with the properties described in the product specification is suitable for use in a particular application. Parameters provided in datasheets and / or specifications may vary in different applications and performance may vary over time. All operating parameters, including typical parameters, must be validated for each customer application by the customer's technical experts. Product specifications do not expand or otherwise modify Vishay's terms and conditions of purchase, including but not limited to the warranty expressed therein.

Except as expressly indicated in writing, Vishay products are not designed for use in medical, life-saving, or life-sustaining applications or for any other application in which the failure of the Vishay product could result in personal injury or death. Customers using or selling Vishay products not expressly indicated for use in such applications do so at their own risk. Please contact authorized Vishay personnel to obtain written terms and conditions regarding products designed for such applications.

No license, express or implied, by estoppel or otherwise, to any intellectual property rights is granted by this document or by any conduct of Vishay. Product names and markings noted herein may be trademarks of their respective owners.