

Federkontakte am Band  
spring contact on carrier strip

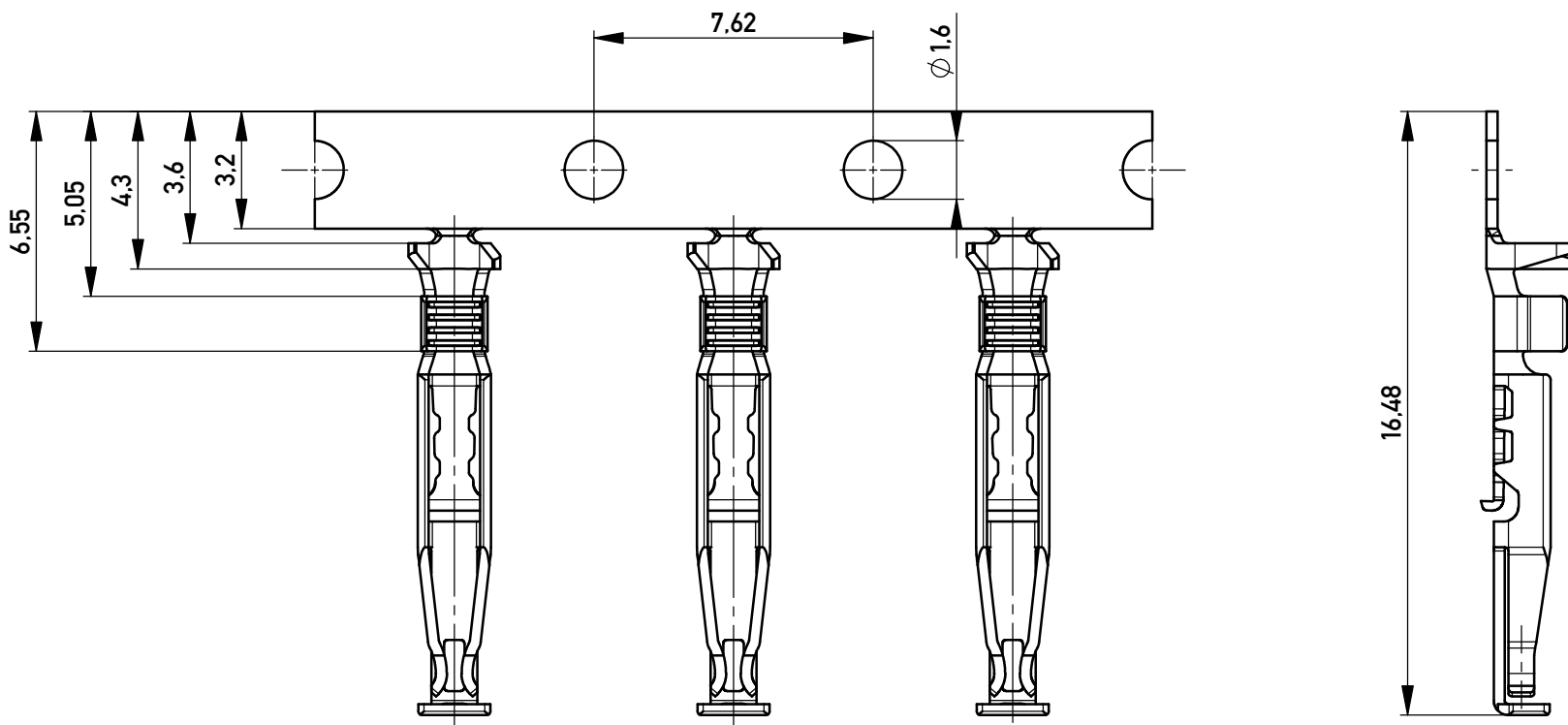

Federkontakt vereinzelt  
spring contact isolated

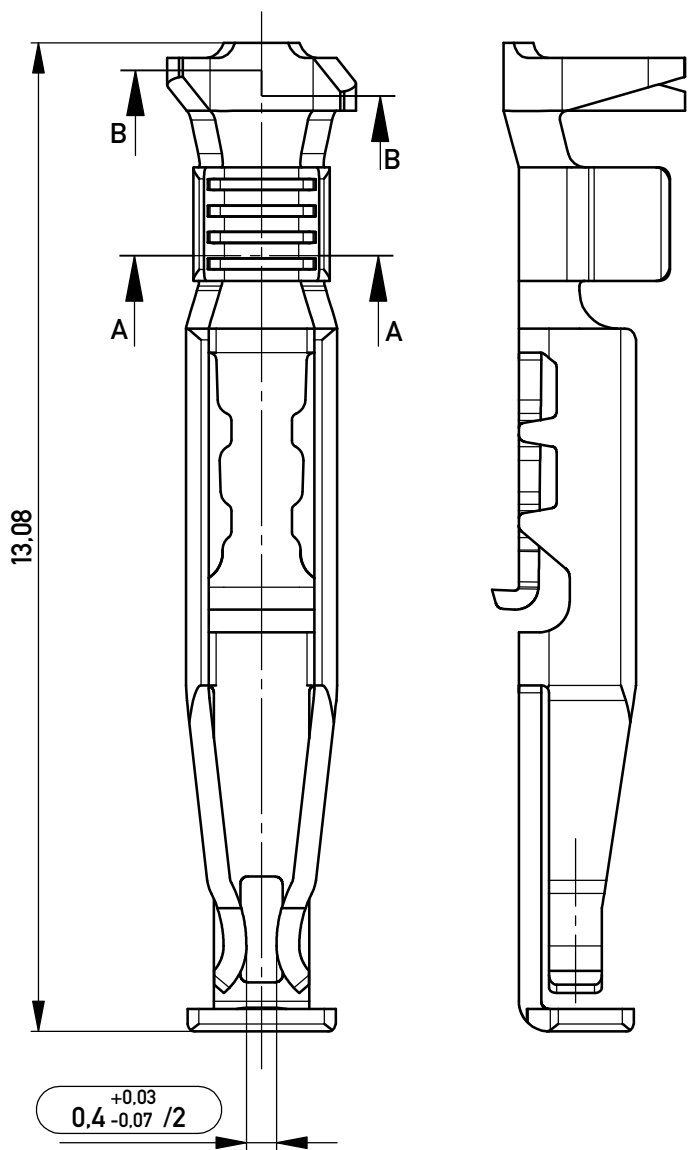

Schnitt A-A  
cross section A-A  
M 10:1

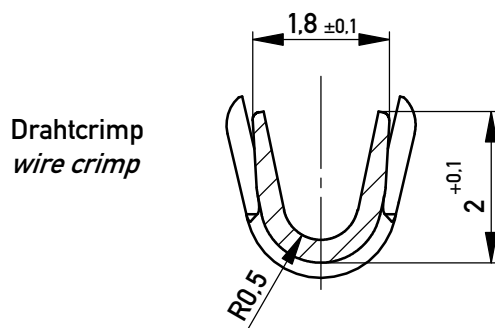

Schnitt B-B  
cross section B-B  
M 10:1

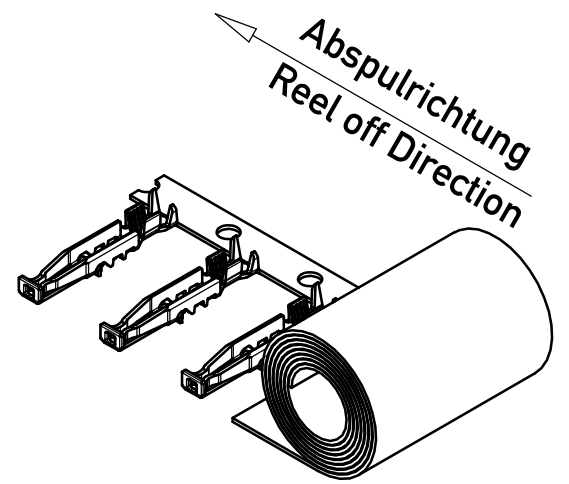
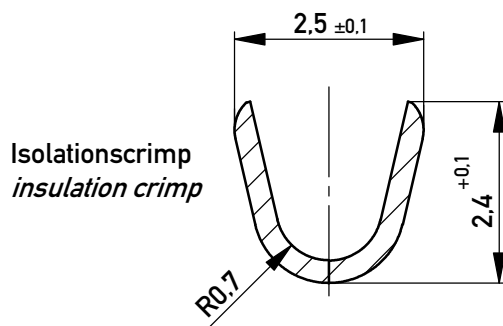

SPC-Maß: Prüfmerkmale der Kategorie /1

/1 Für SPC-Maße muss eine x/s Regelkarte geführt werden mit Nachweis der Prozessfähigkeit in der Serie (Cpk) oder 100% - Prüfung

Prüfmerkmal: Prüfmerkmale der Kategorie /2 und /3

/2 Für Prüfmerkmale muss eine x/s Regelkarte geführt werden

/3 Prüfmerkmale werden serienbegleitend geprüft

<sup>1</sup>AWG 20 für Isolationsdurchmesser < 1,5mm

AWG 20-22 <sup>1</sup>	500	Ø 130	137	
Leiterquerschnitt wire cross section	Menge quantity	Spulendurchmesser reel diameter	Anforderungsstufe class	Bemerkung remark

Information:  All rights reserved. Only for Information. To ensure that this is the latest version of this drawing, please contact one of the ERNI companies before using.	Tolerances	 All Dimensions in mm	Scale 2:1	Material CuNi 2 Si
	Subject to modification without prior notice. Drawing will not be updated.		Designation <b>Federkontakte 2,54 SRC-A BA 2</b> <i>Spring contact 2,54 SRC-A</i>	
Copyright by ERNI Production GmbH & Co. KG Proprietary notice pursuant to ISO 16016 to be observed.	www.ERNI.com	<b>100103200060</b>		K A3
b Index	17.02.2016 Date	Class SRCROL		