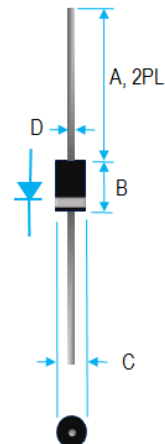

5A ULTRA FAST RECOVERY RECTIFIER

 <table border="1" data-bbox="357 399 698 609"> <thead> <tr> <th rowspan="2">Dim.</th> <th colspan="2">Value Inch[mm]</th> </tr> <tr> <th>Min.</th> <th>Max.</th> </tr> </thead> <tbody> <tr> <td>A</td> <td>1.000[25.40]</td> <td>---</td> </tr> <tr> <td>B</td> <td>0.335[8.51]</td> <td>0.375[9.52]</td> </tr> <tr> <td>C</td> <td>0.197[5.00]</td> <td>0.220[5.59]</td> </tr> <tr> <td>D</td> <td>0.048[1.22]</td> <td>0.052[1.32]</td> </tr> </tbody> </table>	Dim.	Value Inch[mm]		Min.	Max.	A	1.000[25.40]	---	B	0.335[8.51]	0.375[9.52]	C	0.197[5.00]	0.220[5.59]	D	0.048[1.22]	0.052[1.32]	<h3>PRODUCT FEATURES</h3> <ol style="list-style-type: none"> 1. FLAMMABILITY CLASSIFICATION: 94V-0 2. LOW LEAKAGE 3. LOW FORWARD VOLTAGE DROP 4. HIGH SURGE CURRENT CAPABILITY 5. ULTRA FAST SWITCHING 6. CASE: MOLDED PLASTIC, DO-201AD 7. POLARITY: INDICATED BY CATHODE BAND 8. WEIGHT: 1.2 GRAMS 9. LEADS: SOLDERABILITY PER MIL-STD-202 METHOD 208 10. PULLING TEST: 2.3 KG 11. RoHS
Dim.		Value Inch[mm]																
	Min.	Max.																
A	1.000[25.40]	---																
B	0.335[8.51]	0.375[9.52]																
C	0.197[5.00]	0.220[5.59]																
D	0.048[1.22]	0.052[1.32]																

MAXIMUM RATINGS AND ELECTRICAL CHARACTERISTICS RATINGS AT 25°C AMBIENT TEMPERATURE UNLESS OTHERWISE SPECIFIED STORAGE AND OPERATING TEMPERATURE RANGE -55°C TO +150°C. SINGLE PHASE, HALF WAVE, 60 HZ, RESISTIVE OR INDUCTIVE LOAD. FOR CAPACITIVE LOAD, DERATE CURRENT BY 20%.

RATINGS	SYMBOL	VALUE	UNITS
MAXIMUM AVERAGE FORWARD RECTIFIED CURRENT 0.375"(9.5mm) LEAD LENGTH @ TA=50°C	I_o	5	A
PEAK FWD SURGE CURRENT, 8.3ms HALF SINE-WAVE SUPERIMPOSED ON RATED LOAD	I_{FSM}	200	A
TYPICAL THERMAL RESISTANCE (NOTE 2)	$R_{\theta ja}$	15	°C/W
MAXIMUM REVERSE CURRENT @ 25°C	I_R	5	uA
MAXIMUM REVERSE CURRENT @ 100°C	I_R	100	uA

1. C_j MEASURED @ 1 MHZ AND APPLIED REVERSE VOLTAGE OF 4.0 VOLTS
2. BOTH LEADS ATTACHED TO HEAT SINK 63.5x63.5x1t(mm) COPPER PLATE @ LEAD LENGTH 5mm
3. REVERSE RECOVERY TEST CONDITIONS: $I_F=0.5A$, $I_R=1.0A$, $I_{RR}=0.25A$
4. MAXIMUM FORWARD VOLTAGE @ I_o DC

PART NUMBER	MAX RECURRENT PEAK REV VOLTAGE V_{RRM} (V)	MAX RMS VOLTAGE V_{RMS} (V)	MAX DC BLOCKING VOLTAGE V_{DC} (V)	MAX FWD VOLTAGE V_F (V)	TYPICAL CAP. C_j (PF)	MAX REVERSE RECOVERY TIME T_{RR} (nS)
HER501G	50	35	50	1.0	70	50
HER502G	100	70	100	1.0	70	50
HER503G	200	140	200	1.0	70	50
HER504G	300	210	300	1.3	70	50
HER505G	400	280	400	1.3	70	50
HER506G	600	420	600	1.85	50	75
HER507G	800	560	800	1.85	50	75
HER508G	1000	700	1000	1.85	50	75

RATING AND CHARACTERISTIC CURVES

FIG. 1 - TEST CIRCUIT DIAGRAM AND REVERSE RECOVERY TIME CHARACTERISTIC

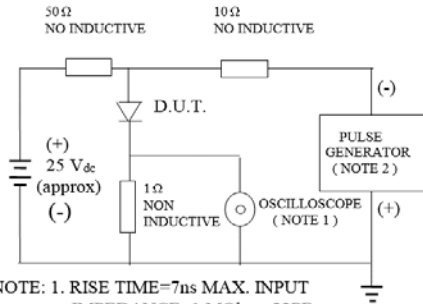

NOTE: 1. RISE TIME=7ns MAX. INPUT IMPEDANCE=1 MOhms 22PF
2. RISE TIME =10 ns MAX. SOURCE IMPEDANCE=50 OHMS

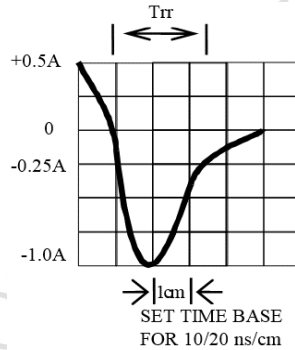

FIG. 2-TYPICAL FORWARD CURRENT DERATING CURVE

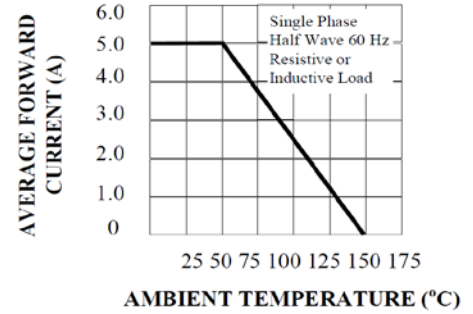

FIG. 3-TYPICAL REVERSE CHARACTERISTICS

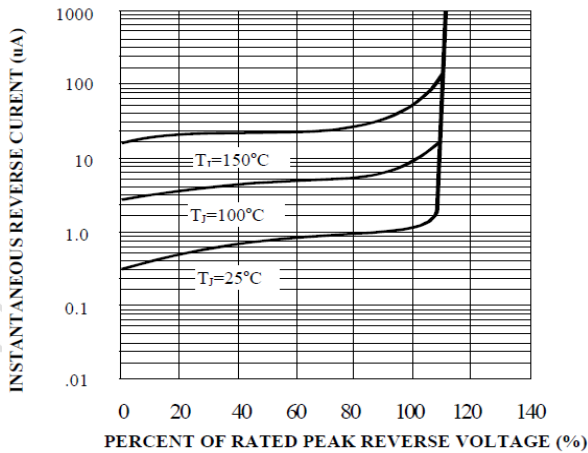

FIG. 4-TYPICAL INSTANTANEOUS FORWARD CHARACTERISTICS

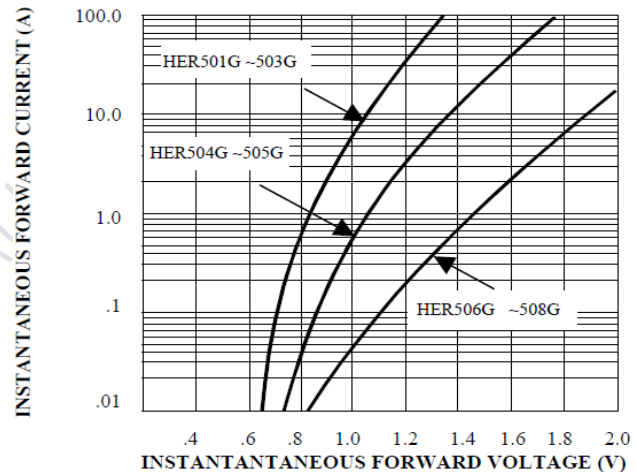

FIG. 5-MAXIMUM NON-REPETITIVE FORWARD SURGE CURRENT

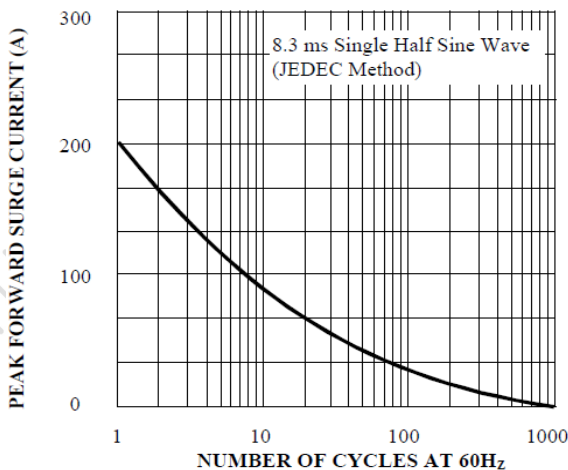

FIG. 6-TYPICAL JUNCTION CAPACITANCE

