Microprocessor power management with Watchdog Timer

NO.EA-136-070201

OUTLINE

The R5104V Series are high voltage tolerance CMOS-based microprocessor power management ICs with high accuracy output voltage and detector threshold and with ultra low supply current. Each of these ICs consists of a voltage regulator, a voltage detector and a watchdog timer. Thus, the R5104V Series have the function of a power management for microprocessor, a monitor of the voltage of a power source and a microprocessor supervisor.

The built-in voltage regulator with an external driver transistor can supply Min.1A current to a system. Therefore these ICs are very suitable for various power supply systems for microprocessors. The output voltage is monitored by the voltage detector which is built-in these ICs.

The built-in voltage detector has an output delay function and the delay time can be set by an external capacitor (C_D).

The output voltage and the detector threshold voltage can be set individually for each IC by laser trimming.

Furthermore, when a microprocessor works incorrectly, the watchdog timer which checks over microprocessor generates reset signals intermittently to prevent a whole system from being malfunction.

The timeout periods for watchdog and reset can also be set individually by an external capacitor (C_{TW}).

There are two kinds of power down function: "A" version turns off the supervisor of clock input for the watchdog timer, while the "B" version turns off all the circuits and realizes the standby mode.

FEATURES

- Low supply current..... Typ. $60\mu\text{A}$ ($I_{OUT}=0\text{mA}$)
- Standby Current (B version)..... Typ. $0.1\mu\text{A}$
- Output Voltage 3.3V to 5.0V
- Detector Threshold Voltage 2.8V to 4.0V
- Maximum Operating Input Voltage..... Max. 36V
- High Accuracy Output Voltage of Voltage Regulator and Detector Threshold $\pm 2.0\%$
- Built-in a watchdog timer
- Timeout period for watchdog and generating a reset signal can be set by an external capacitor
- Watchdog timer can be stopped individually by CE Pin
- Power-on Reset Delay Time can be set by an external capacitor
- Small Package SSOP-10

APPLICATION

- Power source for microprocessors

BLOCK DIAGRAMS

R5104VxxxA

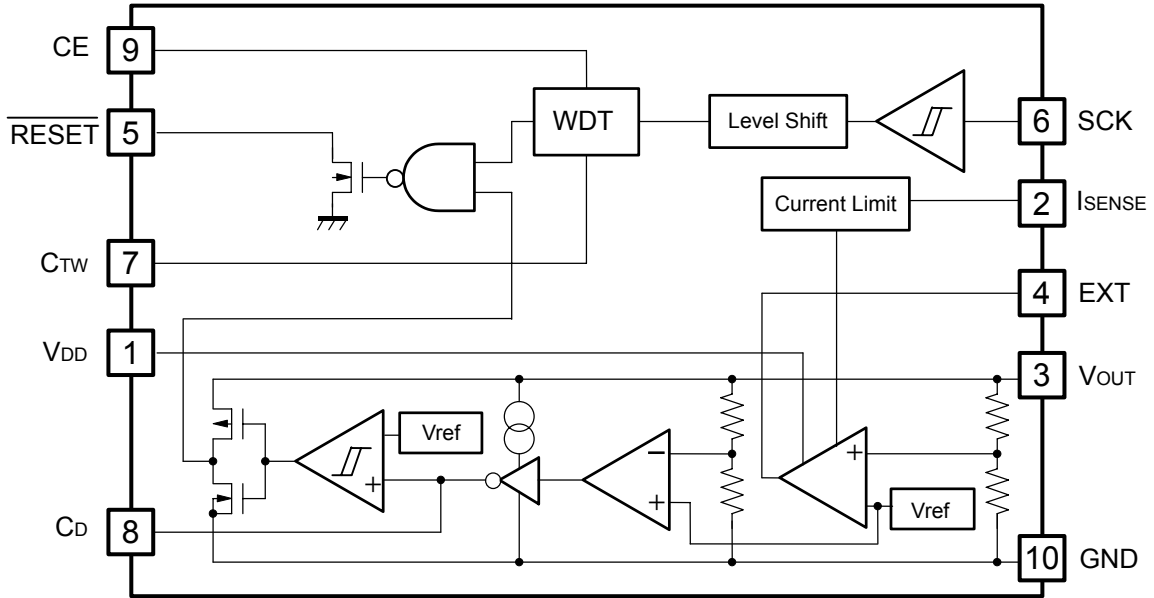

R5104VxxxB

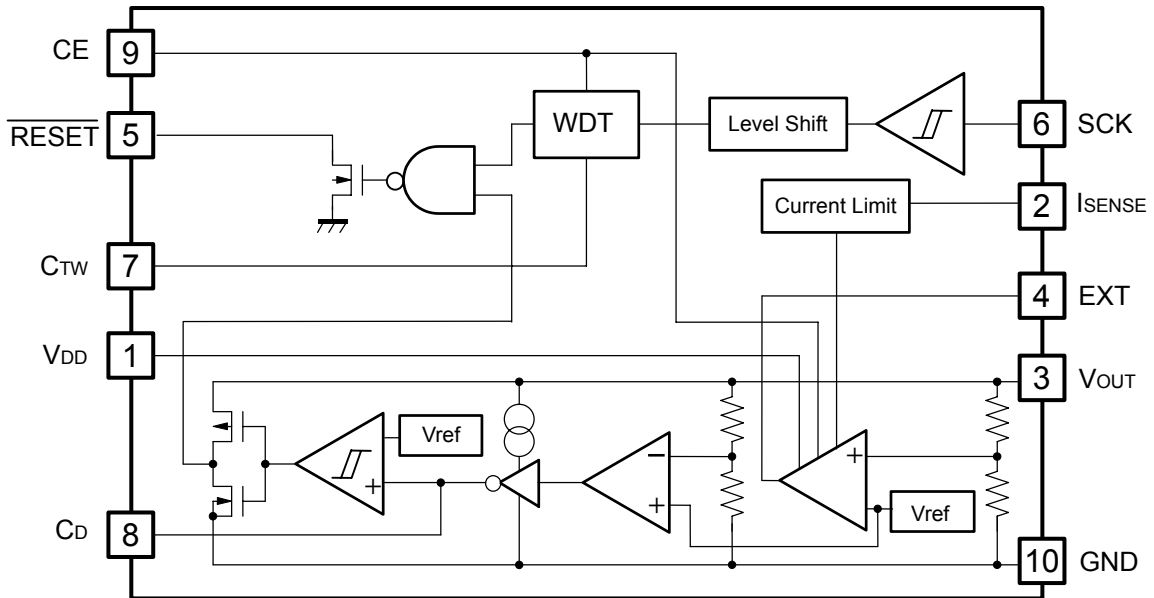

SELECTION GUIDE

The selection can be made with designating the part number as shown below:

R5104V XXXX-XX-X ← Part Number
 ↑ ↑ ↑ ↑ ↑
 a b c d e

Code	Contents
a	Designation of Package Type; V: SSOP-10 (3.1mm×6.4mm)
b	Serial Number for Voltage setting combination from 001
c	Alphabetical Code for Mask Versions (Power-down mode) A: Watchdog timer off type B: Standby mode type
d	Designation of Taping Type E2 is described as standard.
e	Designation of composition of Pin Plating. -F: Lead free Plating

PIN CONFIGURATION

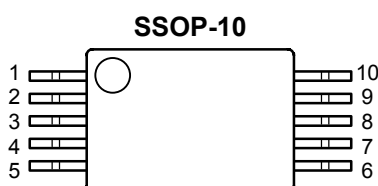

PIN DESCRIPTIONS

Pin No	Symbol	Pin Description
1	V _{DD}	Power supply Pin Clock
2	I _{SENSE}	Sense Pin for Current Limit of VR. Monitoring the dropout voltage generated at an external resistor between pin 1 and pin 2, if the dropout exceeds 0.3V (Typ.), the current limit works.
3	V _{OUT}	Output Pin for Voltage Regulator
4	EXT	External Transistor Drive Pin
5	RESET	Output Pin for Reset signal of Watchdog timer and Voltage Detector. (Output Type is Nch Open Drain, Output "L" at detecting Detector Threshold and Watchdog Timer Reset.)
6	SCK	Clock Input Pin from Microprocessor
7	C _{TW}	External Capacitor Pin for Setting Reset and Watchdog Timeout Periods
8	C _D	External Capacitor Pin for Setting Delay Time of Voltage Detector
9	CE	Control Switch Pin for halting Watchdog timer (A version), or Chip Enable Pin (B version)
10	GND	Ground Pin

ABSOLUTE MAXIMUM RATINGS

Symbol	Item	Rating	Unit	
V_{DD}	Supply Voltage	-0.3~50	V	
V_{PEAK}	Peak Input Voltage (*Note 1)	60	V	
V_{CD}	Output Voltage	Voltage of C_D Pin	$V_{SS}-0.3$ to 7.5	V
V_{CTW}		Voltage of C_{TW} Pin	$V_{SS}-0.3$ to 7.5	V
V_{OUT}		Voltage of V_{OUT} Pin	$V_{SS}-0.3$ to 7.5	V
V_{RESET}		Voltage of \overline{RESET} Pin	$V_{SS}-0.3$ to 7.5	V
V_{CE}	Input Voltage	Voltage of CE Pin	$V_{SS}-0.3\sim V_{IN}+0.3$	V
V_{ISENSE}		Voltage of I_{SENSE} Pin	$V_{SS}-0.3\sim V_{IN}+0.3$	V
V_{SCK}		Voltage of SCK Pin	$V_{SS}-0.3\sim V_{IN}+0.3$	V
I_{EXT}	Output Current	Current of EXT Pin	10	mA
I_{RESET}		Current of \overline{RESET} Pin	20	mA
P_D	Power Dissipation	300	mW	
T_{opt}	Operating Temperature Range	-40~+125	°C	
T_{stg}	Storage Temperature Range	-55~+140	°C	

*Note 1 duration time=200ms

Do not force any voltage more than supply voltage to C_D , C_{TW} , V_{OUT} , and \overline{RESET} pins.

Operational Ratings (Electrical Characteristics)

Application circuits of semiconductors should be designed with operating within the operational ratings of the semiconductors. Even the noise or surge, if their level is beyond the operational ratings, normal operation of the semiconductor may not be expected. If the application circuits make the semiconductor operate beyond the condition of operational ratings, the quality assurance level of the semiconductor cannot be maintained.

Absolute Maximum Ratings

Absolute maximum ratings are threshold limit values that must not be exceeded even for any moment under any conditions. More over, such values for any two or more items of the ratings must not be reached simultaneously. Operation above these absolute maximum ratings may cause degradation or fatal damage to the device. These mean stress ratings and do not necessarily imply functional operation below these limits.

ELECTRICAL CHARACTERISTICS

(Unless otherwise specified, $V_{IN}=CE=V_{ISENSE}=12V$, $I_{OUT}=100mA$, $C_{CTW}=0.1\mu F$, $C_D=0.01\mu F$)

• R5104VxxxA(Overall)

$T_{opt}=25^{\circ}C$

Symbol	Item	Conditions	Min.	Typ.	Max.	Unit
V_{IN}	Operating Voltage				36	V
I_{SS}	Supply Current	$I_{OUT}=0mA$		60	100	μA
I_{off}	Supply Current (WDT inactive)	$V_{IN}=12V$, $CE=0V$		50	90	μA
V_{CEH}	CE Input Voltage "H"		2.0		$V_{IN}+0.3$	V
V_{CEL}	CE Input Voltage "L"		0.00		0.25	V

VR part

Symbol	Item	Conditions	Min.	Typ.	Max.	Unit
V_{OUT}	Output Voltage		$\times 0.98$		$\times 1.02$	V
I_{OUT}	Output Current(*1)	$V_{IN}=12V$	1.0			A
V_{DIF}	Dropout Voltage(*1)	$I_{OUT}=300mA$		50		mV
$\Delta V_{OUT}/\Delta I_{OUT}$	Load Regulation(*1)	$V_{IN}=12V$, $1mA \leq I_{OUT} \leq 1A$		15	60	mV
$\frac{\Delta V_{OUT}}{\Delta V_{IN}}$	Line Regulation(*1)	$I_{OUT}=100mA$ $V_{OUT}+1V \leq V_{IN} \leq 36V$		0.05	0.10	%/V
$\frac{\Delta V_{OUT}}{\Delta T_{opt}}$	Output Voltage Temperature Coefficient (*1)	$-40^{\circ}C \leq T_{opt} \leq 125^{\circ}C$		± 50		ppm/ $^{\circ}C$
I_{SINK1}	EXT Output Sink Current Limit	$V_{IN}=12V$, $V_{OUT}=V_{OUT}-0.2V$	9	14	20	mA
I_{SINK2}	EXT Output Sink Current Limit (Output short)	$V_{IN}=12V$, $V_{OUT}=0V$	0.20	0.50	0.85	mA
V_{ISENSE}	Current Limit Detector Threshold		0.23	0.30	0.37	V
RR	Ripple Rejection	$V_{IN}=V_{OUT}+1V$, $f=1kHz$, $500mVp-p$		55		dB

*1) Depending on the capability of an external PNP transistor. Use an hFE with approximately 100 to 300. The output current does not always mean continuous current because of the limit of power dissipation of PNP transistor.

VD part

Symbol	Item	Conditions	Min.	Typ.	Max.	Unit
$-V_{DET}$	Detector Threshold		$\times 0.98$		$\times 1.02$	V
V_{HYS}	Hysteresis Range		$(-V_{DET}) \times 0.01$	$(-V_{DET}) \times 0.02$	$(-V_{DET}) \times 0.03$	V
$\frac{\Delta -V_{DET}}{\Delta T_{opt}}$	Detector Threshold Temperature Coefficient	$-40^{\circ}C \leq T_{opt} \leq 125^{\circ}C$		± 50		ppm/ $^{\circ}C$
V_{TCD}	C_D pin detector threshold		2.35	2.50	2.65	V
I_{CD}	Internal Current value for Delay Time Setting		0.12	0.30	0.47	μA
V_{INL}	Minimum Operating Voltage	V_{OUT} pin voltage			2.0	V

WDT part

Symbol	Item	Conditions	Min.	Typ.	Max.	Unit
t_{WD}	Watchdog Timeout period	$C_{TW}=0.1\mu F$	200	300	510	ms
t_{WR}	Reset Hold Time of WDT	$C_{TW}=0.1\mu F$	35	70	120	ms
V_{IHCK}	SCK Input Voltage "H"		$0.8 \times V_{OUT}$		$V_{DD}+0.3$	V
V_{ILCK}	SCK Input Voltage "L"		0.0		0.1	V
T_{SCKW}	SCK Input Pulse Width	$-V_{DET} \geq 3.0V$	500			ns
		$-V_{DET} \leq 2.9V$	5000			

R5104V

(Unless otherwise specified, $V_{IN}=CE=V_{ISENSE}=12V$, $I_{OUT}=100mA$, $C_{CTW}=0.1\mu F$, $C_D=0.01\mu F$)

● R5104VxxxB (Overall)

$T_{opt}=25^{\circ}C$

Symbol	Item	Conditions	Min.	Typ.	Max.	Unit
V_{IN}	Operating Voltage				36	V
I_{SS}	Supply Current	$I_{OUT}=0mA$		60	100	μA
I_{off}	Supply Current (Standby)	$V_{IN}=12V$, $CE=0V$		0.1	0.5	μA
V_{CEH}	CE Input Voltage "H"		2.0		$V_{IN}+0.3$	V
V_{CEL}	CE Input Voltage "L"		0.0		0.25	V

VR part

Symbol	Item	Conditions	Min.	Typ.	Max.	Unit
V_{OUT}	Output Voltage		$\times 0.98$		$\times 1.02$	V
I_{OUT}	Output Current(*Note 1)	$V_{IN}=12V$	1.0			A
V_{DIF}	Dropout Voltage(*Note 1)	$I_{OUT}=300mA$		50		mV
$\Delta V_{OUT}/\Delta I_{OUT}$	Load Regulation(*Note 1)	$V_{IN}=12V$, $1mA \leq I_{OUT} \leq 1A$		15	60	mV
$\frac{\Delta V_{OUT}}{\Delta V_{IN}}$	Line Regulation(*Note 1)	$I_{OUT}=100mA$ $V_{OUT}+1V \leq V_{IN} \leq 36V$		0.05	0.10	%/V
$\frac{\Delta V_{OUT}}{\Delta T_{opt}}$	Output Voltage Temperature Coefficient (*Note 1)	$-40^{\circ}C \leq T_{opt} \leq 125^{\circ}C$		± 50		ppm/ $^{\circ}C$
I_{SINK1}	EXT Output Sink Current Limit	$V_{IN}=12V$, $V_{OUT}=V_{OUT}-0.2V$	9	14	20	mA
I_{SINK2}	EXT Output Sink Current Limit (Output short)	$V_{IN}=12V$, $V_{OUT}=0V$	0.20	0.50	0.85	mA
V_{ISENSE}	Current Limit Detector Threshold		0.23	0.30	0.37	V
RR	Ripple Rejection	$V_{IN}=V_{OUT}+1V$, $f=1kHz$, $500mVp-p$		55		dB

*1) Depending on the capability of an external PNP transistor. Use an hFE with approximately 100 to 300. The output current does not always mean continuous current because of the limit of power dissipation of PNP transistor.

VD part

Symbol	Item	Conditions	Min.	Typ.	Max.	Unit
$-V_{DET}$	Detector Threshold		$\times 0.98$		$\times 1.02$	V
V_{HYS}	Hysteresis Range		$(-V_{DET}) \times 0.01$	$(-V_{DET}) \times 0.02$	$(-V_{DET}) \times 0.03$	V
$\frac{\Delta -V_{DET}}{\Delta T_{opt}}$	Detector Threshold Temperature Coefficient	$-40^{\circ}C \leq T_{opt} \leq 125^{\circ}C$		± 50		ppm/ $^{\circ}C$
V_{TCD}	C_D pin detector threshold		2.35	2.50	2.65	V
I_{CD}	Internal Current value for Delay Time Setting		0.12	0.30	0.47	μA
V_{INL}	Minimum Operating Voltage	V_{OUT} pin Voltage			2.0	V

WDT part

Symbol	Item	Conditions	Min.	Typ.	Max.	Unit
t_{WD}	Watchdog Timeout period	$C_{TW}=0.1\mu F$	200	300	510	ms
t_{WR}	Reset Hold Time of WDT	$C_{TW}=0.1\mu F$	35	70	130	ms
V_{IHCK}	SCK Input Voltage "H"		$0.8 \times V_{OUT}$		$V_{DD}+0.3$	V
V_{ILCK}	SCK Input Voltage "L"		0.0		0.1	V
T_{SCKW}	SCK Input Pulse Width	$-V_{DET} \geq 3.0V$	500			ns
		$-V_{DET} \leq 2.9V$	5000			

(Unless otherwise specified, $V_{IN}=CE=V_{ISENSE}=12V$, $I_{OUT}=100mA$, $C_{CTW}=0.1\mu F$, $C_D=0.01\mu F$)

● R5104V007A (Overall)

$T_{opt}=25^{\circ}C$

Symbol	Item	Conditions	Min.	Typ.	Max.	Unit
V_{IN}	Operating Voltage				36	V
I_{SS}	Supply Current	$I_{OUT}=0mA$		45	80	μA
I_{off}	Supply Current (WDT inactive)	$V_{IN}=12V$, $CE=0V$		45	80	μA
V_{CEH}	CE Input Voltage "H"		2.0		$V_{IN}+0.3$	V
V_{CEL}	CE Input Voltage "L"		0.00		0.25	V

VR part

Symbol	Item	Conditions	Min.	Typ.	Max.	Unit
V_{OUT}	Output Voltage		$\times 0.98$		$\times 1.02$	V
I_{OUT}	Output Current(*1)	$V_{IN}=12V$	1.0			A
V_{DIF}	Dropout Voltage(*1)	$I_{OUT}=300mA$		50		mV
$\frac{\Delta V_{OUT}}{\Delta I_{OUT}}$	Load Regulation(*1)	$V_{IN}=12V$, $1mA \leq I_{OUT} \leq 1A$		15	60	mV
$\frac{\Delta V_{OUT}}{\Delta V_{IN}}$	Line Regulation(*1)	$I_{OUT}=100mA$ $V_{OUT}+1V \leq V_{IN} \leq 36V$		0.05	0.10	%/V
$\frac{\Delta V_{OUT}}{\Delta T_{opt}}$	Output Voltage Temperature Coefficient (*1)	$-40^{\circ}C \leq T_{opt} \leq 125^{\circ}C$		± 50		ppm/ $^{\circ}C$
I_{SINK1}	EXT Output Sink Current Limit	$V_{IN}=12V$, $V_{OUT}=V_{OUT}-0.2V$	9	14	20	mA
I_{SINK2}	EXT Output Sink Current Limit (Output short)	$V_{IN}=12V$, $V_{OUT}=0V$	0.20	0.50	0.85	mA
V_{ISENSE}	Current Limit Detector Threshold		0.23	0.30	0.37	V
RR	Ripple Rejection	$V_{IN}=V_{OUT}+1V$, $f=1kHz$, $500mV_{p-p}$		55		dB

*1) Depending on the capability of an external PNP transistor. Use an hFE with approximately 100 to 300. The output current does not always mean continuous current because of the limit of power dissipation of PNP transistor.

VD part

Symbol	Item	Conditions	Min.	Typ.	Max.	Unit
$-V_{DET}$	Detector Threshold		$\times 0.98$		$\times 1.02$	V
V_{HYS}	Hysteresis Range		$(-V_{DET}) \times 0.01$	$(-V_{DET}) \times 0.02$	$(-V_{DET}) \times 0.03$	V
$\frac{\Delta -V_{DET}}{\Delta T_{opt}}$	Detector Threshold Temperature Coefficient	$-40^{\circ}C \leq T_{opt} \leq 125^{\circ}C$		± 50		ppm/ $^{\circ}C$
V_{TCD}	C_D pin detector threshold		2.35	2.50	2.65	V
I_{CD}	Internal Current value for Delay Time Setting		0.12	0.30	0.47	μA
V_{INL}	Minimum Operating Voltage	V_{OUT} pin Voltage			2.0	V

WDT part

Symbol	Item	Conditions	Min.	Typ.	Max.	Unit
t_{WD}	Watchdog Timeout period	$C_{TW}=0.1\mu F$	200	300	510	ms
t_{WR}	Reset Hold Time of WDT	$C_{TW}=0.1\mu F$	35	70	130	ms
V_{IHCK}	SCK Input Voltage "H"		$0.8 \times V_{OUT}$		$V_{DD}+0.3$	V
V_{ILCK}	SCK Input Voltage "L"		0.0		0.1	V
T_{SCKW}	SCK Input Pulse Width	$-V_{DET} \geq 3.0V$	500			ns
		$-V_{DET} \leq 2.9V$	5000			

TIMING CHART

R5104VxxxA

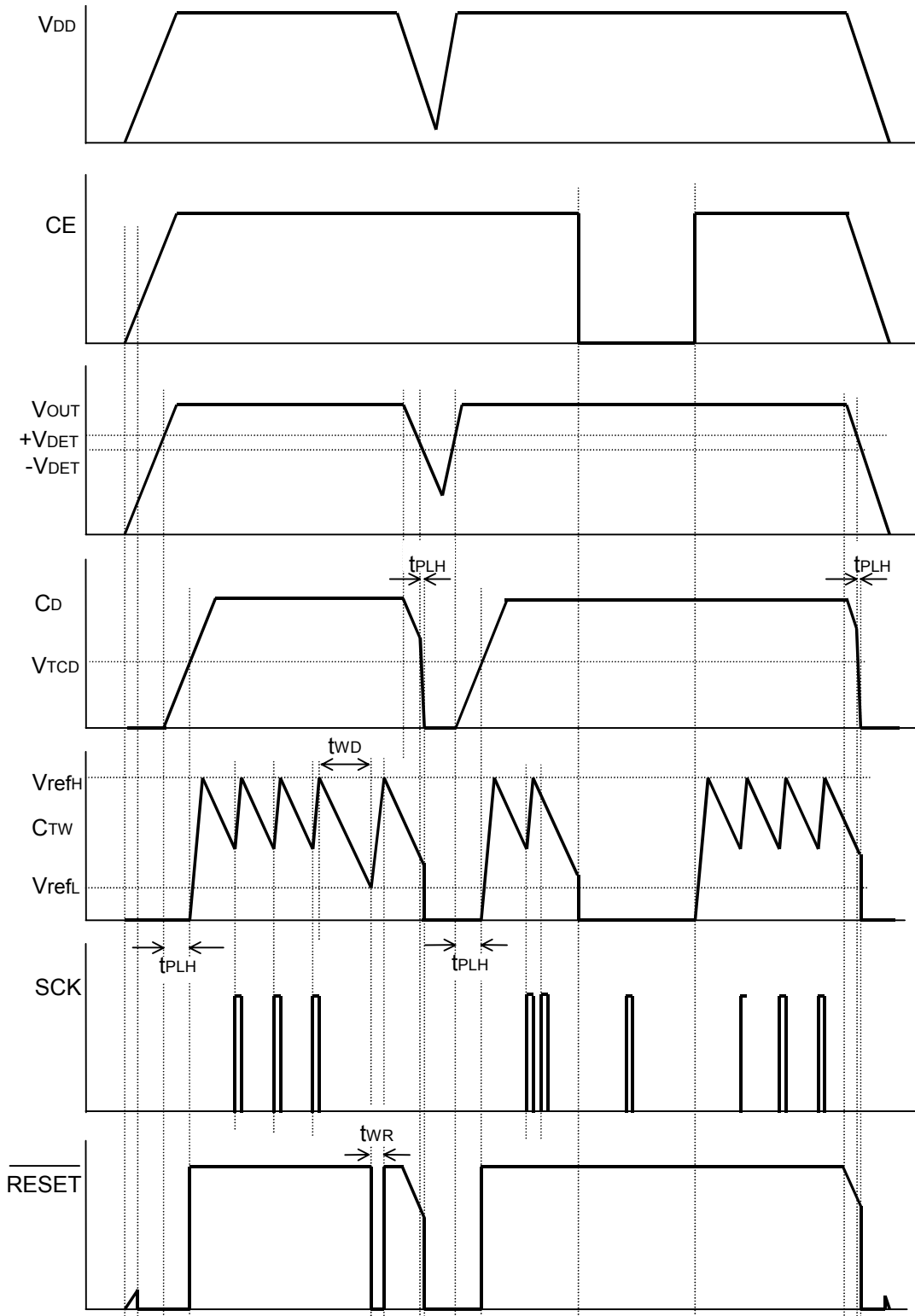

R5104VxxxB

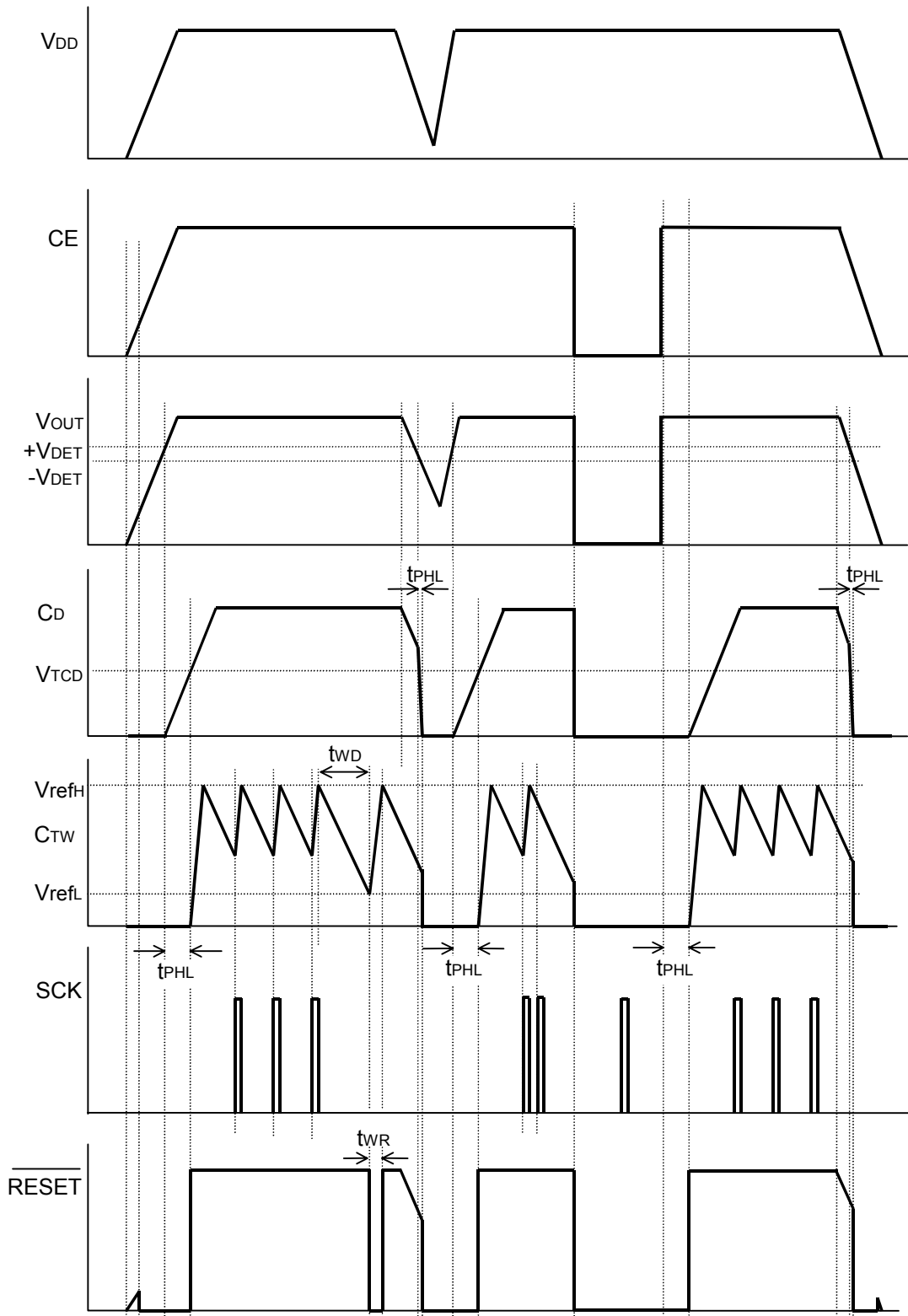

OPERATION

R5104VxxxA (Watchdog Timer On/Off type)

The R5104VxxxA have the function that turns off the clock input of the watchdog timer. When the watchdog timer is enabled (CE="H"), the output of the internal regulator and SCK input pulse are supervised, while the watchdog timer is disabled (CE="L"), only the regulator is supervised.

R5104VxxxB (Standby Function)

Since the standby function is included in the R5104VxxxB, the consumption current of the system can be reduced. The supply current at the standby mode is very small, typically 0.1μA.

Output Delay Time Setting of the built-in voltage detector

The released delay time from reset of the voltage detector (t_{PLH}) can be calculated with the external capacitor value C_D and the next formula.

$$t_{PLH} = V_{TCD} \times C_D / I_{CD} \text{ (S)}$$

On the other hand, output delay time for detecting voltage (t_{PHL}) is not specified, the time depends on the capacitance value of C_D .

TYPICAL APPLICATION

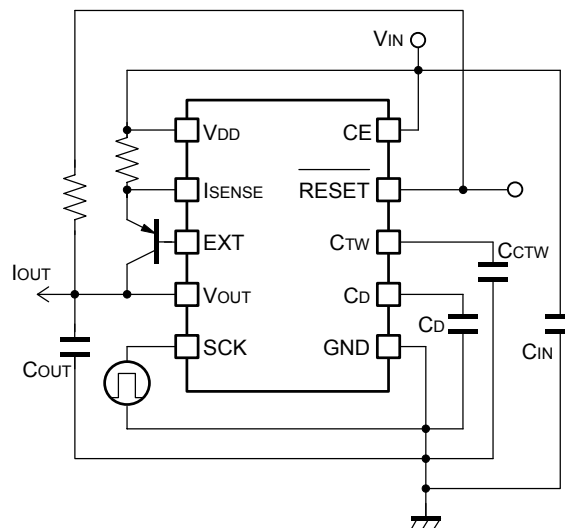

TEST CIRCUITS

Standard Test Circuit

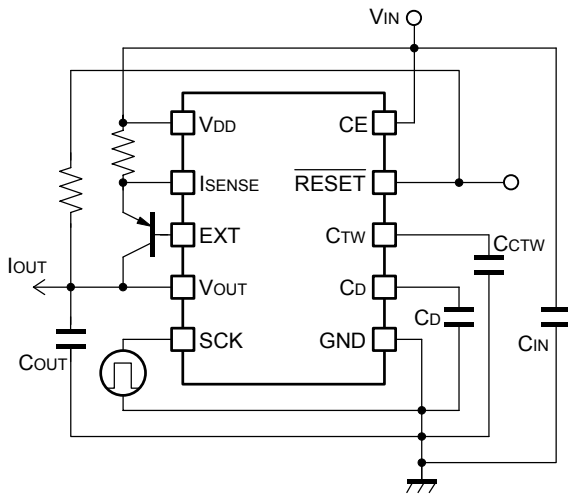

Test Circuit of Supply Current

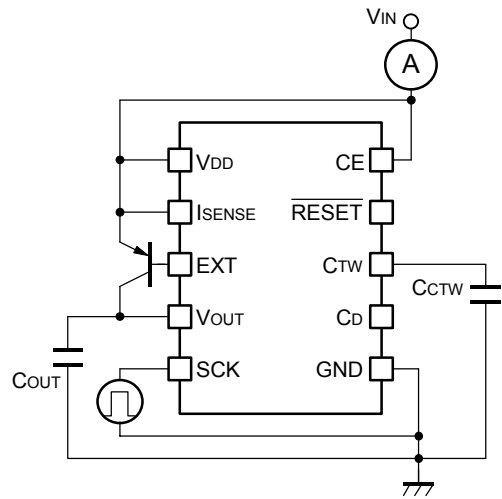

Test Circuit of Standby Current

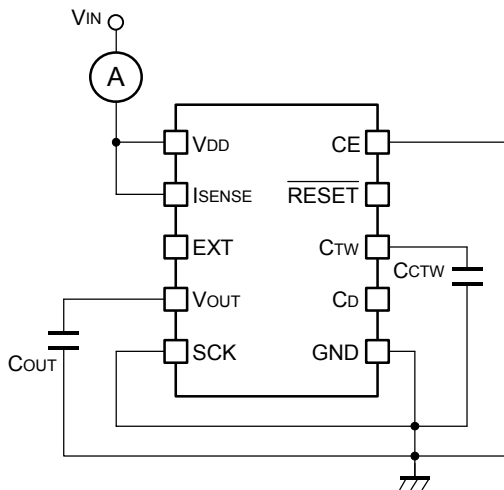

Test Circuit of EXT Sink Current

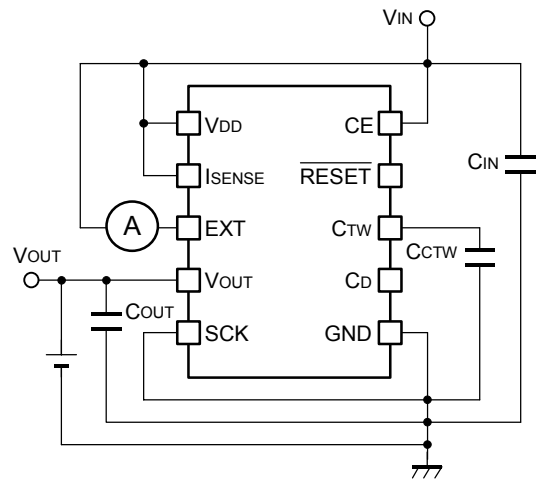

Test Circuit of Ripple Rejection

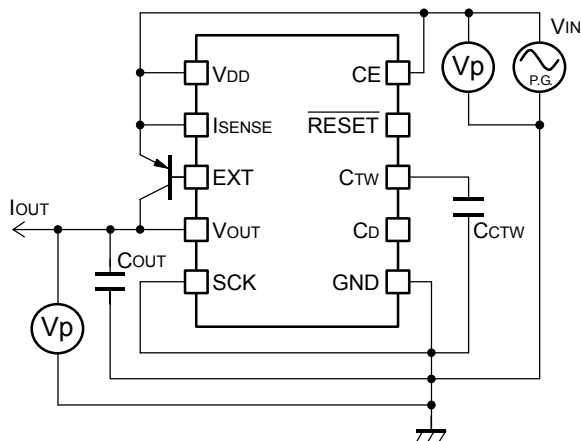

TYPICAL CHARACTERISTICS

(Unless otherwise provided, $V_{IN}=V_{ISENSE}=CE=12V$, $C_{IN}=0.1\mu F$, $C_{OUT}=10\mu F$, $C_{TW}=0.1\mu F$, $C_D=10\mu F$, $T_{opt}=25^\circ C$)

1) Output Voltage vs. Output Current

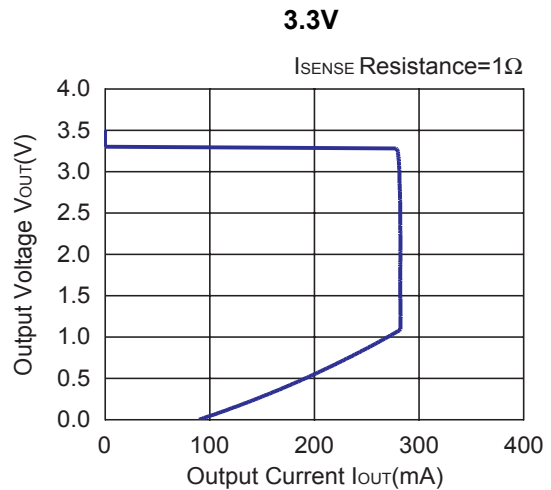
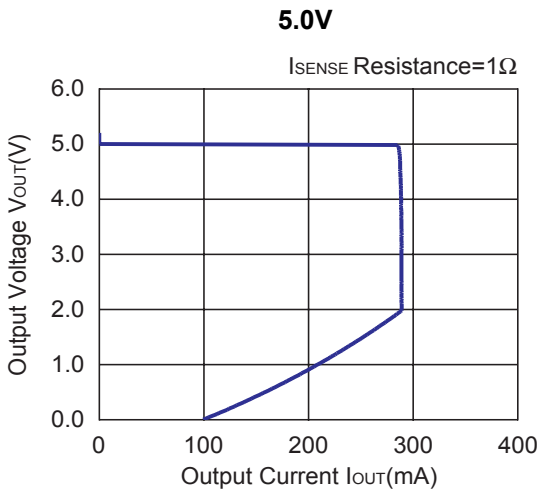
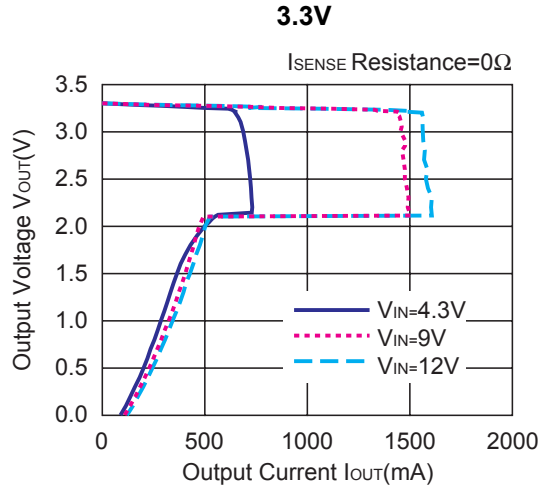
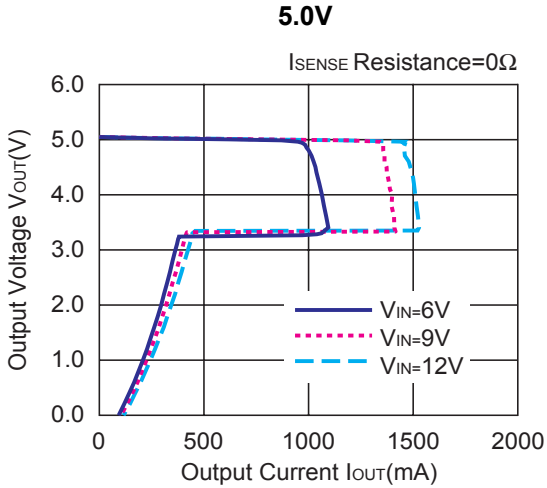

2) Output Voltage vs. Input Voltage

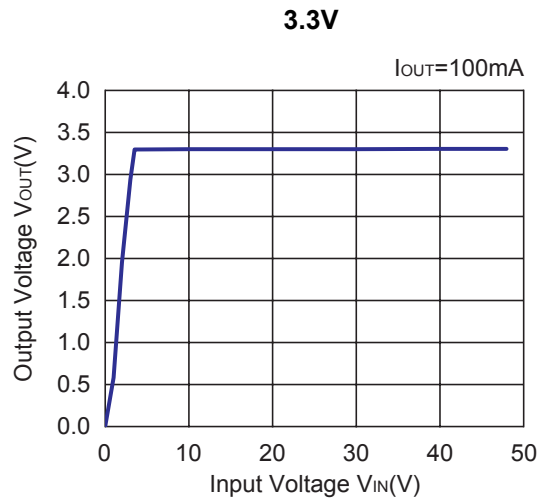
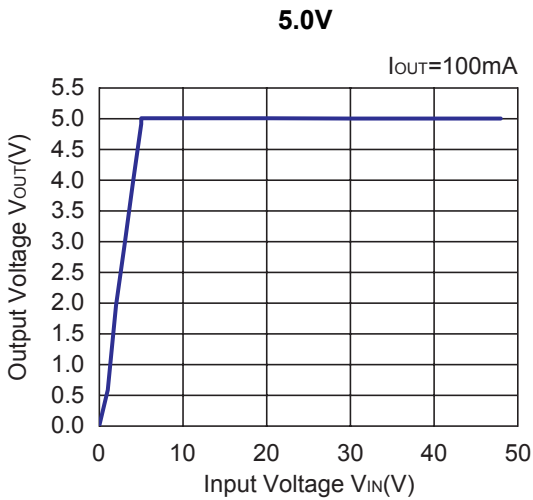

3) Output Voltage vs. Temperature

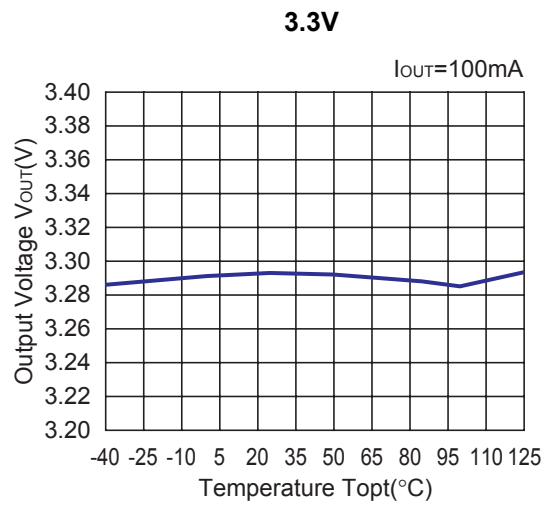
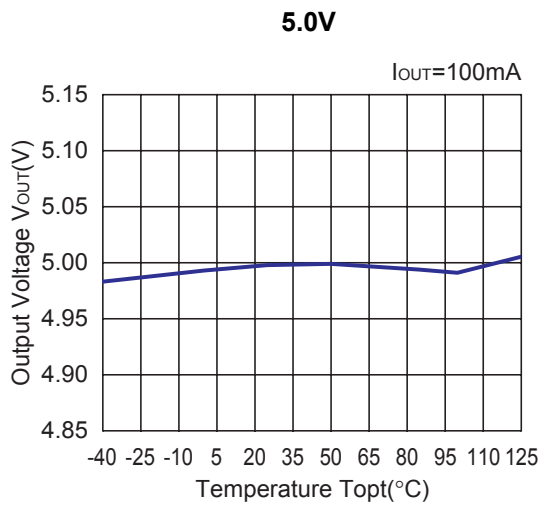

4) Base Current Limit vs. Output Voltage

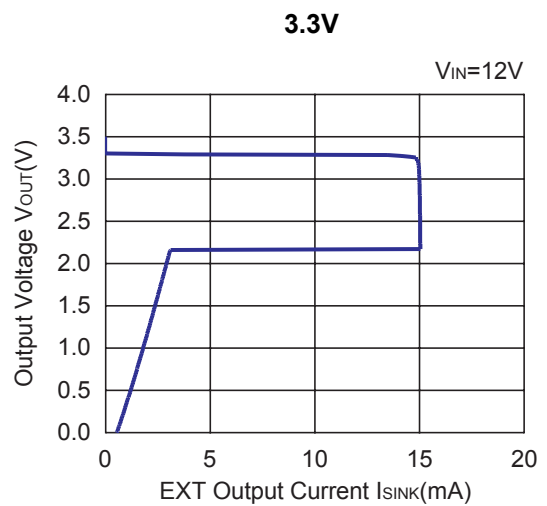
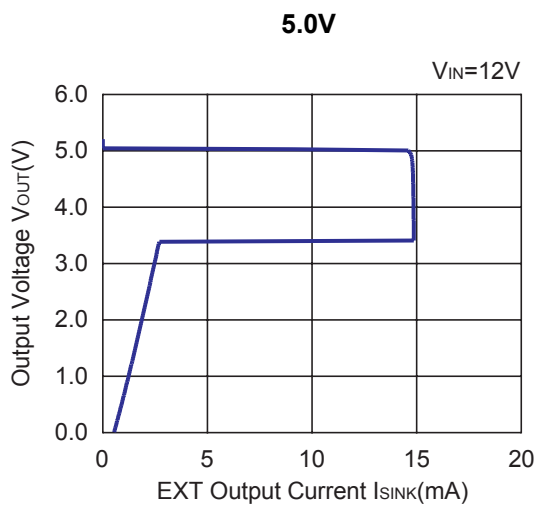

5) Ripple Rejection vs. Frequency

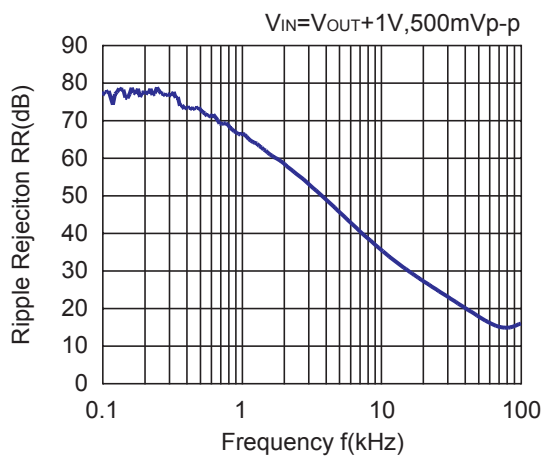

6) Input Transient Response

5.0V

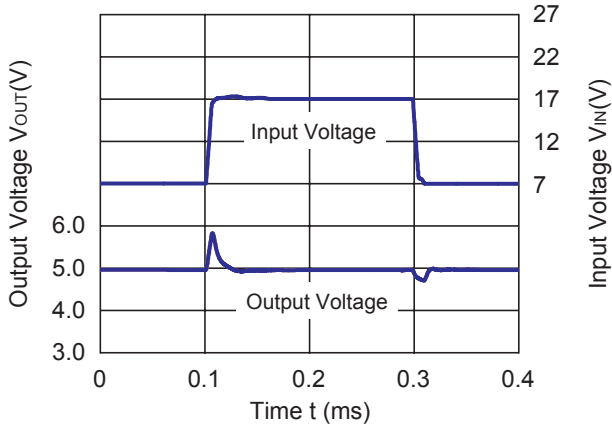

3.3V

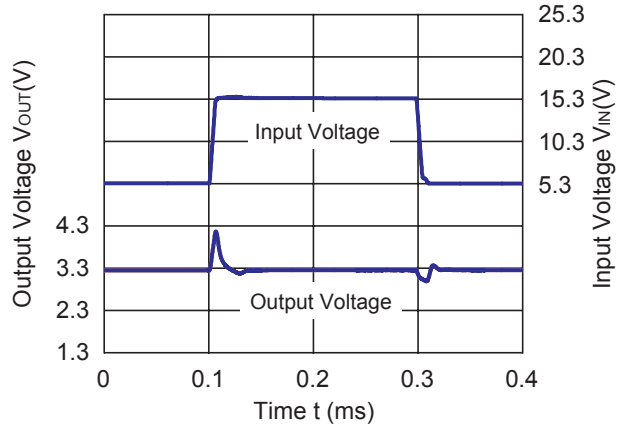

7) Load Transient Response

5.0V

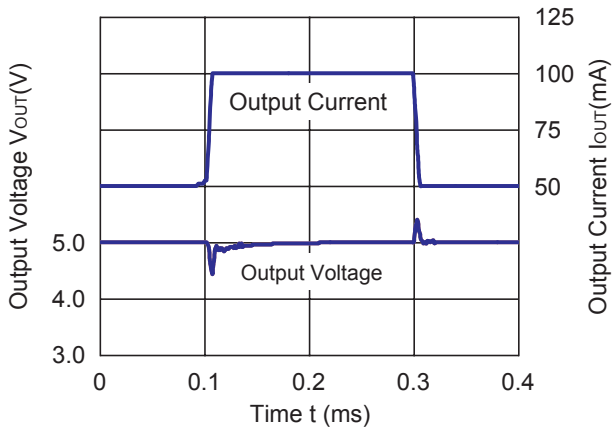

3.3V

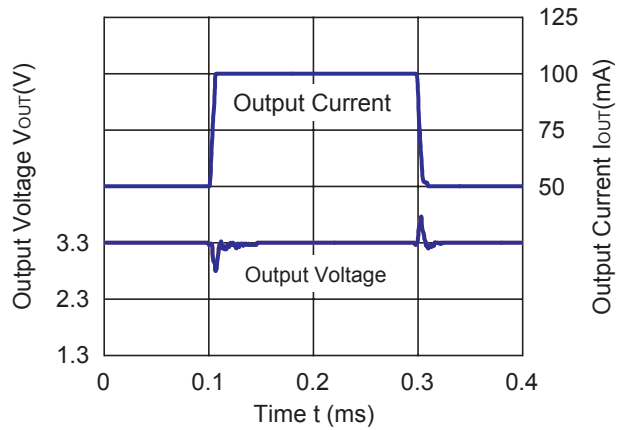

8) Detector Threshold vs. Temperature

4.0V

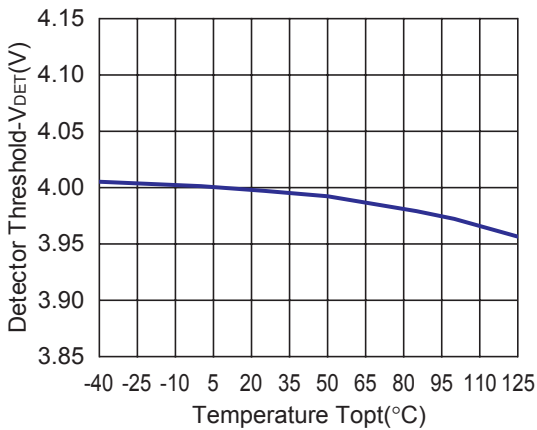

2.8V

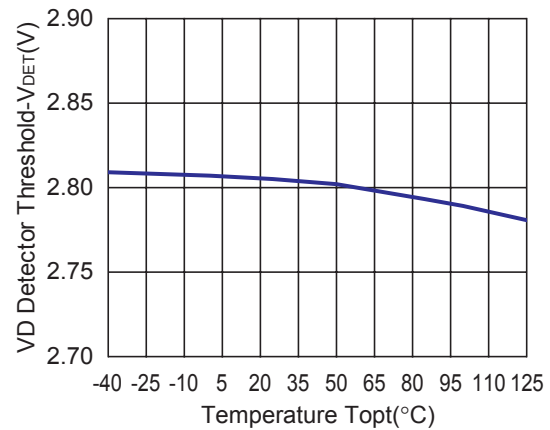

9) Output Voltage vs. Output Current

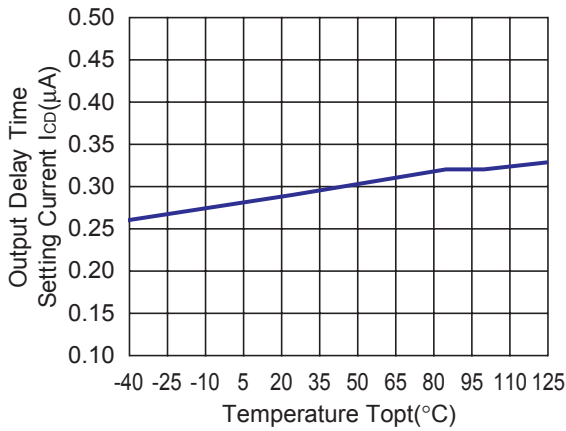

10) C_D Pin Threshold vs. Temperature

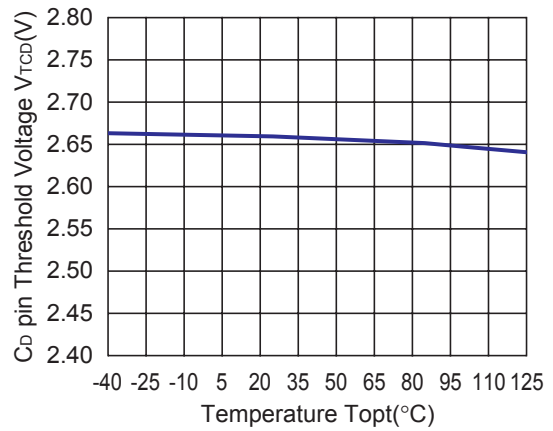

11) C_D Pin External Capacitance vs. Delay Time

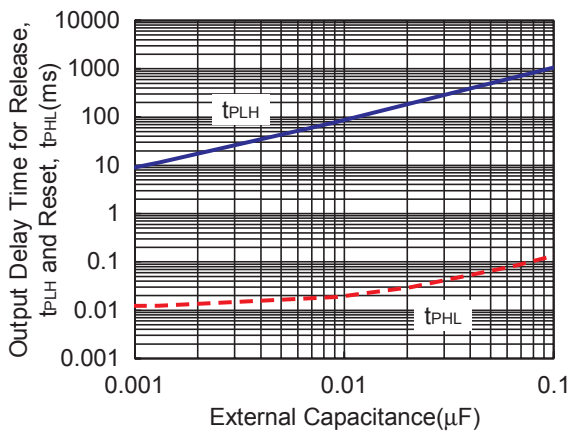

12) WDT monitoring Time vs. Temperature

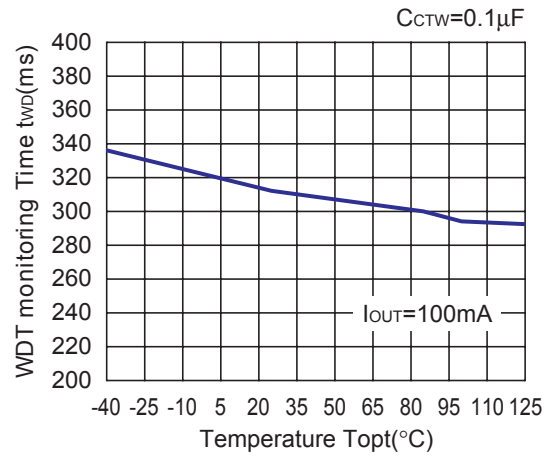

13) WDT Reset Time vs. Temperature

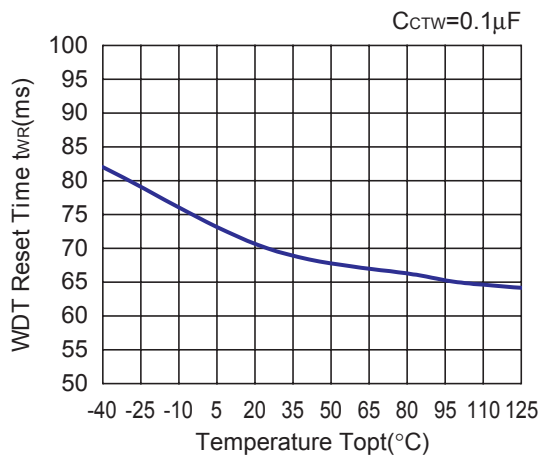

14) External Capacitance vs. WDT monitoring/Reset Time

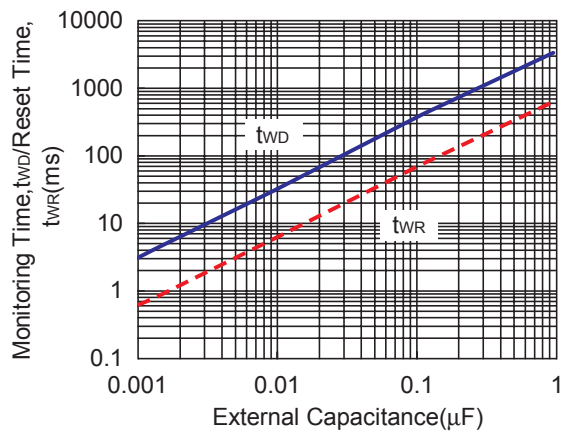

15) Supply Current vs. Temperature

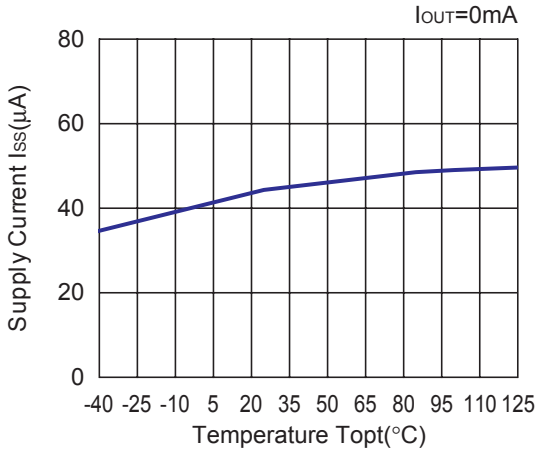

16) Supply Current vs. Input Voltage

5.0V

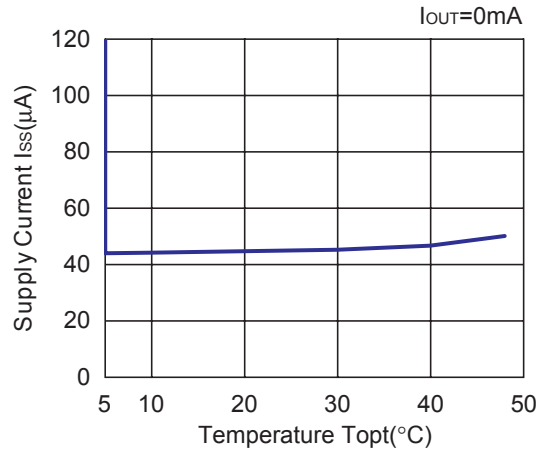

17) Current limit detector threshold vs. Temperature

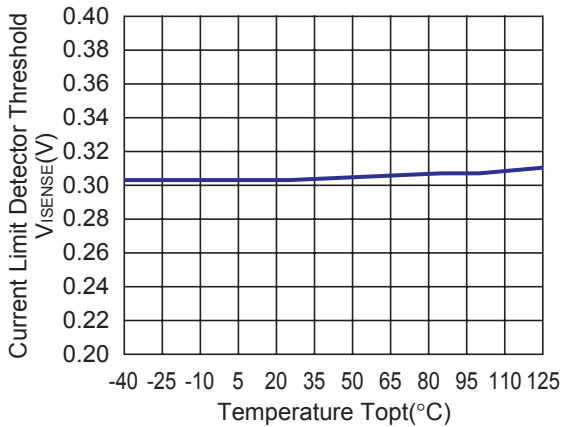

18) Nch Driver Output Current vs. V_{DS}

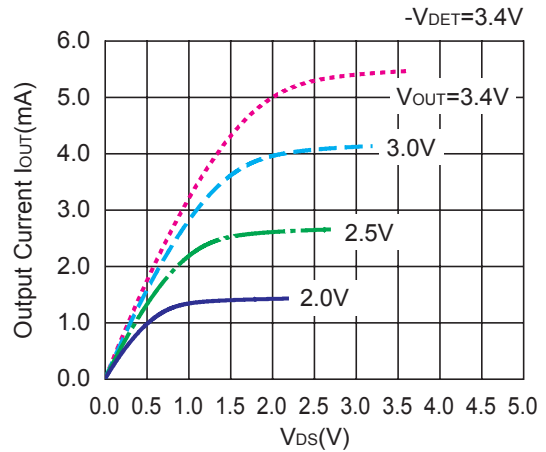

19) Nch Driver Output Current vs. V_{GS}

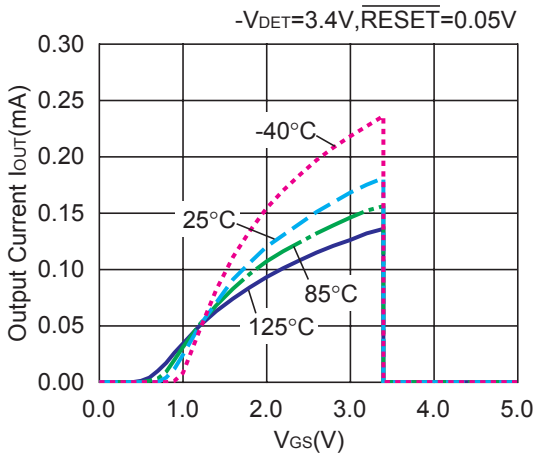

TECHNICAL NOTES

The phase compensation is made with the phase compensation circuit in the IC and the ESR of the output capacitor to make the operation stable. Therefore connect a 10 μ F or more value capacitor between V_{OUT} and GND. The ESR range of the output capacitor should be approximately 1 Ω to 10 Ω .

The fluctuation and the noise of the supply voltage, or a drastic change of the output voltage by the load transition of the regulator might be the reason of the mis-operation of the watchdog timer. If the SCK input pulse frequency is beyond 10kHz, or if the capacitance value of C_{TW} pin is large, the watchdog timer is easily affected by the fluctuation or noise of the supply voltage, or the fluctuation of the regulator output voltage, and it may cause an unstable operation.

If V_{IN} (supply voltage) may swing momentary, the regulator output is also swings. If the output of the voltage regulator becomes lower than detector voltage threshold, the built-in detector may generate the reset signal.

Built-in over-current limit works as monitoring the sink current of EXT pin and limits the current. Considering the over-current of the corrector current caused by short of EXT pin and GND externally, set a resistor between EXT pin and the base of the external driver transistor to limit the base current.

Use a 100pF or more value capacitor for C_{TW} pin.

Use a 10pF or more capacitor for C_D pin. A capacitor must be connected to C_D pin to use R5104VxxxA.

To avoid the mis-operation, during watchdog timer monitoring time, there is some ignoring time against clock pulse. Therefore, during the ignoring time, input clock pulse (rising edge trigger) is ignored. The ignoring time V_{REF2H} is approximately as follows:

The time interval for C_{TW} pin voltage from V_{REF2H} to V_{REF2H}-(V_{REF2H}-V_{REF2L})/4

• SSOP-10

Unit: mm

PACKAGE DIMENSIONS

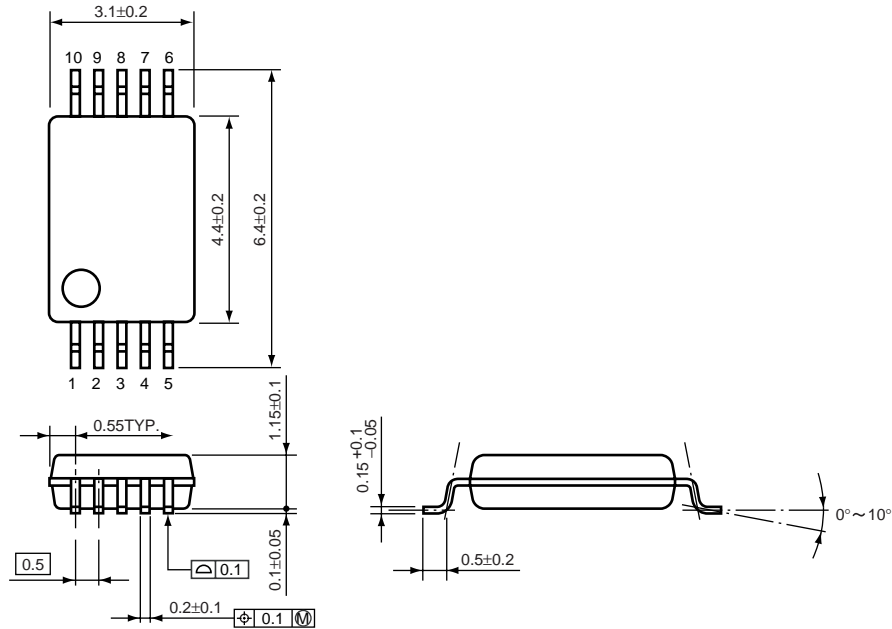

TAPING SPECIFICATION

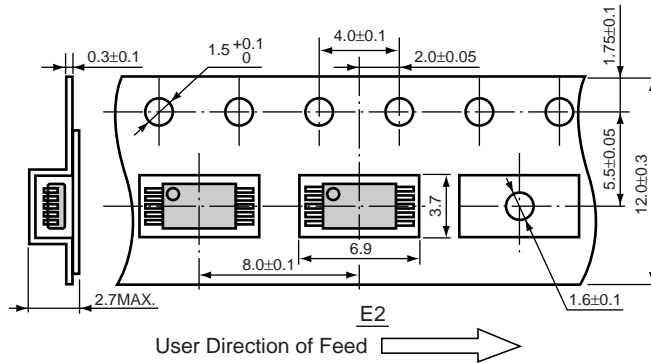

TAPING REEL DIMENSIONS

(1reel=2000pcs)

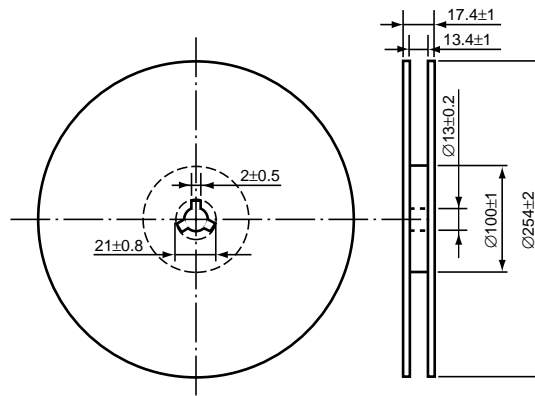

POWER DISSIPATION (SSOP-10)

This specification is at mounted on board. Power Dissipation (P_D) depends on conditions of mounting on board. This specification is based on the measurement at the condition below:

Measurement Conditions

	Standard Land Pattern
Environment	Mounting on Board (Wind velocity=0m/s)
Board Material	Glass cloth epoxy plactic (Single sided)
Board Dimensions	10mm × 10mm × 1.6mm
Copper Ratio	Approx. 10%
Through-hole	–

Measurement Result

($T_{opt}=25^{\circ}\text{C}$, $T_{jmax}=125^{\circ}\text{C}$)

	Standard Land Pattern	Free Air
Power Dissipation	450mW	300mW
Thermal Resistance	$\theta_{ja}=(125-25^{\circ}\text{C})/0.45\text{W}=222^{\circ}\text{C/W}$	333 $^{\circ}\text{C/W}$

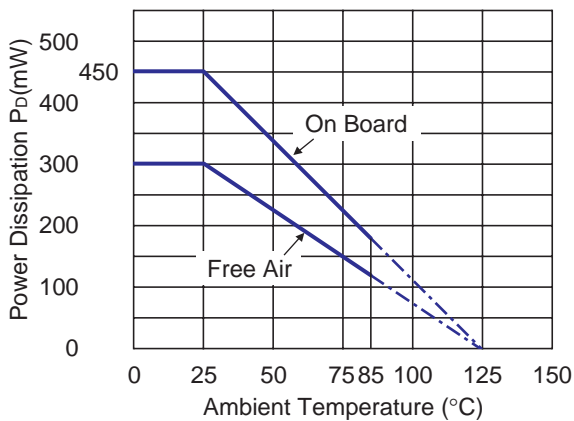

Power Dissipation

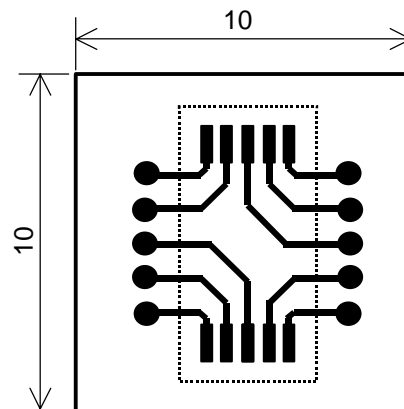

Measurement Board Pattern

○ IC Mount Area (Unit : mm)

RECOMMENDED LAND PATTERN

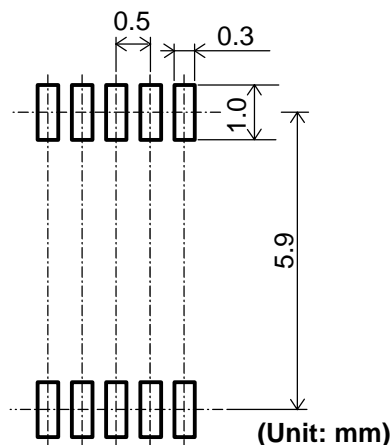

R5104V SERIES MARK SPECIFICATION

● **SSOP-10 (0.5mm pitch)**

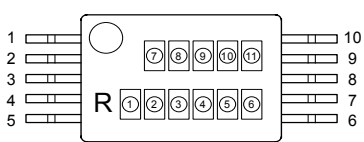

- ① to ④ : 5104 (Fixed)
- ⑤ to ⑦ : Product Code (refer to Part Number vs. Product Code)
- ⑧ to 11 : Lot No.

● **Part Number vs. Product Code**

Part Number	Product Code						
	①	②	③	④	⑤	⑥	⑦
R5104V002A	5	1	0	4	0	2	A
R5104V002B	5	1	0	4	0	2	B
R5104V003A	5	1	0	4	0	3	A
R5104V003B	5	1	0	4	0	3	B
R5104V004A	5	1	0	4	0	4	A
R5104V004B	5	1	0	4	0	4	B
R5104V007A	5	1	0	4	0	7	A
R5104V007B	5	1	0	4	0	7	B
R5104V008A	5	1	0	4	0	8	A
R5104V008B	5	1	0	4	0	8	B