



PRODUCT SPECIFICATION

Part Number

PT322435D-TLMWD-EH25

CUSTOMER	
CUSTOMER PART NUMBER	
DESCRIPTION	
APPROVED BY	
DATE	

**P-TEC****MODEL NO.**

PT322435D-TLMWD-EH25

SPEC & SAMPLE

PAGE

2

1. Table of Contents

No.	Contents	Page
1	Table of Contents	2
2	Record of Revisions	3
3	Module Numbering System	4
4	Application	5
5	Features	5
6	General Specifications	5
7	Absolute Maximum Ratings	6
8	Electrical Characteristics	7
9	Block Diagram	9
10	Input / Output Terminals Pin Assignment	10
11	Interface Timing	13
12	Instruction Description	17
13	Optical Characteristics	18
14	Reliability Test	21
15	Packaging	22
16	Precautions	23
17	Outline Drawing	25
18	Definition of Labels	26
19	Incoming Inspection Standards	28



3. Module Numbering System

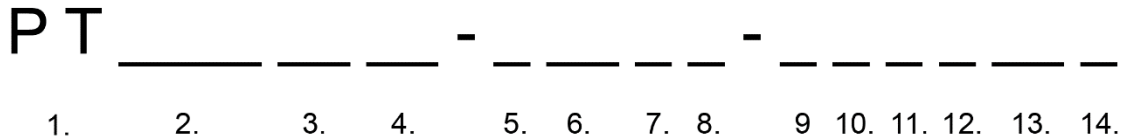

1. P-TEC TFT

8. VIEWING DIRECTION

D: 6 o'clock
U: 12 o'clock
F: Full Viewing Angle

2. LENGTH x WIDTH PIXELS

If third character is a zero, it is removed to shorten part number. Example: 240 x 320 = PT3224

9. A ~ Z CODE

Assigned by P-tec

3. DIAGONAL DIMENSIONS

Example: 3.5" display = 35 in part number

11. TEMPERATURE RANGE

Normal: Left Blank
Wide: X

4. PRODUCT VERSION

Series assigned by P-tec

12. LUMINANCE

Blank: Normal (<300 nit)
M: Middle (>= 300 nit)
H: High (> 600 nit)

5. LCD MODE

T: TN
I: IPS
V: VA

13. TOUCH PANEL OPTION

No TP: Left Blank
C: Capacitive TP
R: Resistive TP

6. POLARIZER

LM: Transmissive
LF: Transflective

14. SPECIAL CHARACTERS

Customer special requirements

7. BACKLIGHT COLOR

No Backlight: Left Blank
W: White
B: Blue/Green
S: Yellow/Green



4. Application

This specification is applied to the 3.5 inch QVGA supported TFT-LCD module, and can display 262k colors. The module is designed for PMP, GPS application and other electronic products which require flat panel display of digital signal interface.

5. Features

- QVGA (320×240 pixels) resolution
- Display in 262k colors
- Digital 24 bit parallel RGB + Serial Peripheral Interface (SPI)
- Line inversion mode with stripe type
- On-chip voltage generator
- SYNC mode is supported for digital RGB input data format
- This display has extended temperature range.

6. General Specifications

Item	Specifications	Unit
Screen Size	3.5 (Diagonal)	inch
Display Format	320RGB(H)×240(V)	dot
Active Area	70.08(H)×52.56(V)	mm
Dot Pitch	0.073(H)×0.219(V)	mm
Pixel Configuration	RGB Vertical Stripe	-
Display Mode	TN Type Transmissive Mode Normally White	-
Surface Treatment	Anti-Glare and Hard Coating(3H)	-
Viewing Direction	6 O'clock (The Gray Inversion will appear at this direction)	-
Outline Dimension	76.9(W)×63.9(H)×3.3(D)	mm
DC to DC circuit	Build-in	-
Weight	(32)	g
RoHS Compliance	P-tec certifies this product to be in compliance with European Union Directive 2002/95/EC on the restriction of certain hazardous substances in electrical and electronic equipment.	-



7. Absolute Maximum Ratings

7.1 Absolute Ratings of Environment

Item	Symbol	Value		Unit	Note
		Min.	Max.		
Storage Temperature	T _{ST}	-40	+80	°C	(1)(2)
Operating Temperature	T _{OP}	-30	+80	°C	(1)(2)

Note1: Background color changes slightly depending on ambient temperature.

This phenomenon is reversible.

Note2: Please refer to item of RELIABILITY.

7.2 Electrical Absolute Ratings

7.2.1 TFT-LCD Module

(Ta=25±2°C, GND=V_{SS}=0V)

Item	Symbol	Value		Unit	Note
		Min.	Max.		
Digital Power Supply Voltage	V _{CC}	V _{SS} -0.3	5.0	V	-

7.2.2 Backlight Unit

(Ta=25±2°C)

Item	Symbol	Value		Unit	Note
		Min.	Max.		
Forward current	I _f	-	(50)	mA	(1)
Reverse voltage	V _r	-	(25)	V	(1)

Note (1) Permanent damage to the device may occur if maximum values are exceeded or reverse voltage is loaded.



8. Electrical Characteristics

8.1 TFT-LCD Module

(Ta=25±2°C)

Item	Symbol	Value			Unit	Note
		Min.	Typ.	Max.		
Digital Power Supply Voltage	V _{CC}	2.5	3.3	3.6	V	-
Input High Threshold Voltage	V _{IH}	0.8V _{CC}	-	V _{CC}	V	-
Input Low Threshold Voltage	V _{IL}	0	-	0.2V _{CC}	V	-

(GND=V_{SS}=0V)

Parameter	SYMBOL	Condition	Min	Typ	Max	Unit	Remarks
Digital Current	I _{VCC}	V _{CC} = 3.3V	-	15.6	22.0	mA	(1)
Total Power Consumption	PC	V _{CC} = 3.3V	-	51.48	72.6	mW	(1)

Note (1) The specified power consumption is under the conditions at V_{CC}=3.3V, F_V=60Hz, whereas a power dissipation check pattern below is displayed.

Black Pattern / 0 Gray

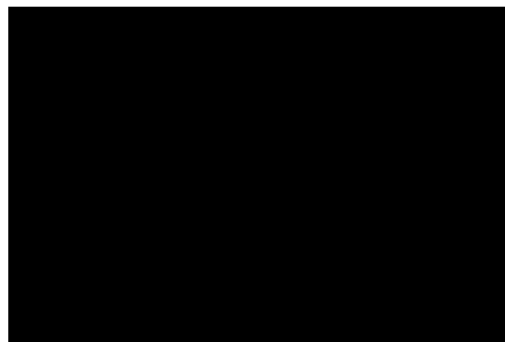

Active Area



8.2 Backlight Unit

(Ta=25±2°C)

Item	Symbol	Value			Unit	Note
		Min.	Typ.	Max.		
LED Voltage	VL	-	(16.5)	-	V	(1)
LED Current	IL	-	(40)	-	mA	(1)
Power Consumption	P _{BL}	-	(660)	-	mW	(1)
LED Life Time(25°C)	-	10000	30000	-	hr	(2)

Note (1) The driving design of backlight unit is dependent on serial consideration of 5S2P LEDs.

Note (2) LED life time is defined as under 25±2°C, when the average brightness decrease to 50% of original brightness



9. Block Diagram

TFT-LCD Module with Backlight Unit

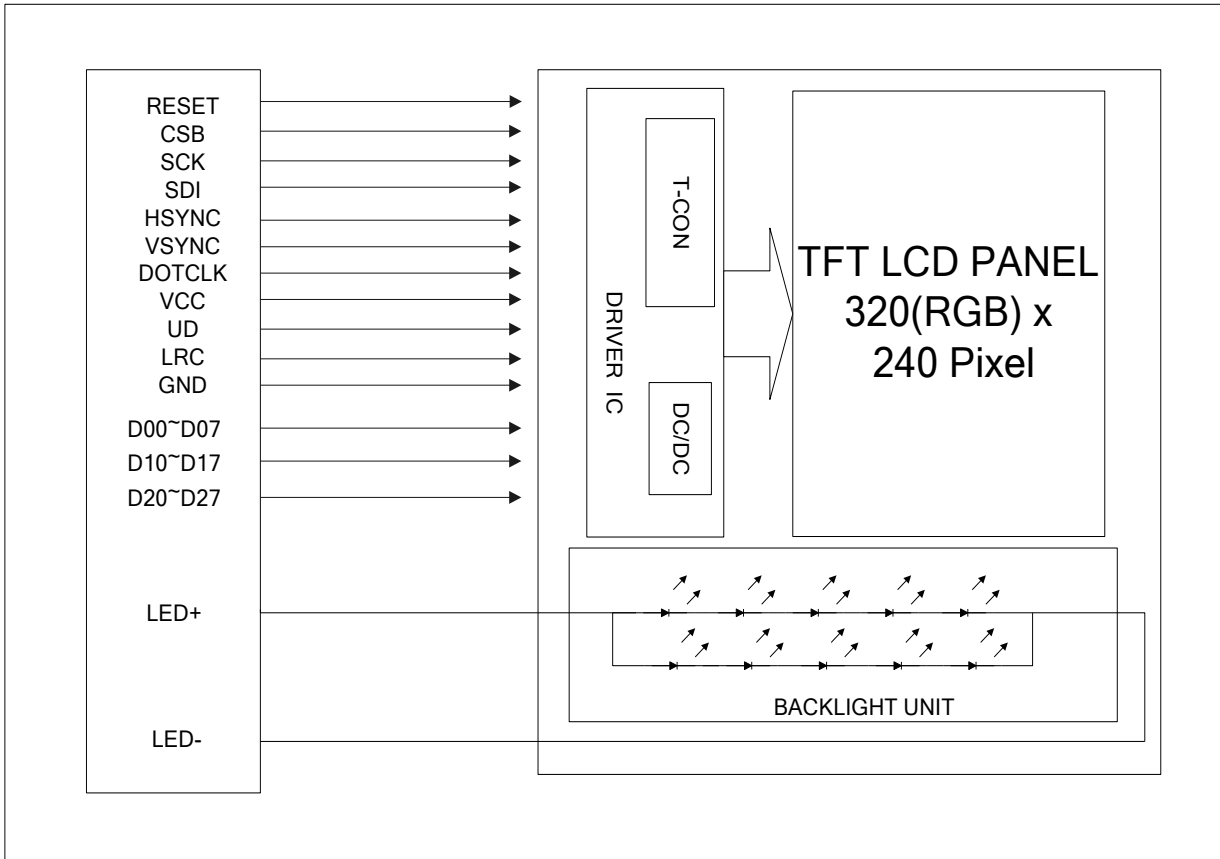



10. Input / Output Terminals Pin Assignment

10.1 TFT-LCD Module

Pin No.	Symbol	I/O	Description
1	LED-	I	LED_cathode
2	LED-	I	LED_cathode
3	LED+	I	LED_anode
4	LED+	I	LED_anode
5	NC	I	No connection
6	NC	I	No connection
7	NC	I	No connection
8	RESET	I	Reset
9	CSB	I	CHIP SELECT
10	SCK	I	Serial Clock
11	SDI	I	Serial Data input
12	D20	I	Blue data(LSB)
13	D21	I	Blue data
14	D22	I	Blue data
15	D23	I	Blue data
16	D24	I	Blue data
17	D25	I	Blue data
18	D26	I	Blue data
19	D27	I	Blue data(MSB)
20	D10	I	Green data(LSB)
21	D11	I	Green data
22	D12	I	Green data
23	D13	I	Green data
24	D14	I	Green data
25	D15	I	Green data
26	D16	I	Green data
27	D17	I	Green data(MSB)
28	D00	I	Red data(LSB)
29	D01	I	Red data
30	D02	I	Red data



Pin No.	Symbol	I/O	Description
31	D03	I	Red data
32	D04	I	Red data
33	D05	I	Red data
34	D06	I	Red data
35	D07	I	Red data(MSB)
36	HSYNC	I	Horizontal synchronous signal(IHS)
37	VSYNC	I	Vertical synchronous signal(IVS)
38	DOTCLK	I	Data Colck(CLK)
39	NC	I	No connection
40	NC	I	No connection
41	V _{CC}	I	Vdigital
42	V _{CC}	I	Vdigital
43	NC	I	No connection
44	NC	I	No connection
45	NC	I	No connection
46	UD	I	Up/down scan setting. ("H": normal scan. "L": Up-and-Down reversal.)
47	NC	I	No connection
48	LRC	I	Right-and-Left scan setting. ("H" : Normally , "L" : Right-and-Left reversal)
49	GND	I	Ground
50	NC	I	No connection
51	NC	I	No connection
52	NC	I	No connection
53	GND	I	Ground
54	GND	I	Ground



10.2 Color Data Input Assignment

The brightness of each primary color(red, green and blue) is based on the 8 bit gray scale data input for the color. The higher the binary input, the brighter the color. The table provides the assignment of color versus data input.

Color		Data Signal																							
		Red								Green								Blue							
		D07	D06	D05	D04	D03	D02	D01	D00	D17	D16	D15	D14	D13	D12	D11	D10	D27	D26	D25	D24	D23	D22	D21	D20
Basic Colors	Black	0	0	0	0	0	0	0	0	0	0	0	0	0	0	0	0	0	0	0	0	0	0	0	
	Red	1	1	1	1	1	1	1	1	0	0	0	0	0	0	0	0	0	0	0	0	0	0	0	
	Green	0	0	0	0	0	0	0	0	1	1	1	1	1	1	1	1	0	0	0	0	0	0	0	
	Blue	0	0	0	0	0	0	0	0	0	0	0	0	0	0	0	0	1	1	1	1	1	1	1	
	Cyan	0	0	0	0	0	0	0	0	1	1	1	1	1	1	1	1	1	1	1	1	1	1	1	
	Magenta	1	1	1	1	1	1	1	1	0	0	0	0	0	0	0	0	1	1	1	1	1	1	1	
	Yellow	1	1	1	1	1	1	1	1	1	1	1	1	1	1	1	1	0	0	0	0	0	0	0	
	White	1	1	1	1	1	1	1	1	1	1	1	1	1	1	1	1	1	1	1	1	1	1	1	
Gray Scale Of RED	Red(0) / Dark	0	0	0	0	0	0	0	0	0	0	0	0	0	0	0	0	0	0	0	0	0	0		
	Red(1)	0	0	0	0	0	0	0	1	0	0	0	0	0	0	0	0	0	0	0	0	0	0		
	Red(2)	0	0	0	0	0	0	1	0	0	0	0	0	0	0	0	0	0	0	0	0	0	0		
	:	:	:	:	:	:	:	:	:	:	:	:	:	:	:	:	:	:	:	:	:	:	:		
	:	:	:	:	:	:	:	:	:	:	:	:	:	:	:	:	:	:	:	:	:	:	:		
	Red(253)	1	1	1	1	1	1	0	1	0	0	0	0	0	0	0	0	0	0	0	0	0	0		
	Red(254)	1	1	1	1	1	1	1	0	0	0	0	0	0	0	0	0	0	0	0	0	0	0		
	Red(255)	1	1	1	1	1	1	1	1	0	0	0	0	0	0	0	0	0	0	0	0	0	0		
Gray Scale Of Green	Green(0) / Dark	0	0	0	0	0	0	0	0	0	0	0	0	0	0	0	0	0	0	0	0	0	0		
	Green(1)	0	0	0	0	0	0	0	0	0	0	0	0	0	0	1	0	0	0	0	0	0	0		
	Green(2)	0	0	0	0	0	0	0	0	0	0	0	0	0	1	0	0	0	0	0	0	0	0		
	:	:	:	:	:	:	:	:	:	:	:	:	:	:	:	:	:	:	:	:	:	:	:		
	:	:	:	:	:	:	:	:	:	:	:	:	:	:	:	:	:	:	:	:	:	:	:		
	Green(253)	0	0	0	0	0	0	0	0	1	1	1	1	1	1	0	1	0	0	0	0	0	0		
	Green(254)	0	0	0	0	0	0	0	0	1	1	1	1	1	1	1	0	0	0	0	0	0	0		
	Green(255)	0	0	0	0	0	0	0	0	1	1	1	1	1	1	1	0	0	0	0	0	0	0		
Gray Scale Of Blue	Blue(0) / Dark	0	0	0	0	0	0	0	0	0	0	0	0	0	0	0	0	0	0	0	0	0	0		
	Blue(1)	0	0	0	0	0	0	0	0	0	0	0	0	0	0	0	0	0	0	0	0	0	1		
	Blue(2)	0	0	0	0	0	0	0	0	0	0	0	0	0	0	0	0	0	0	0	0	0	1		
	:	:	:	:	:	:	:	:	:	:	:	:	:	:	:	:	:	:	:	:	:	:	:		
	:	:	:	:	:	:	:	:	:	:	:	:	:	:	:	:	:	:	:	:	:	:	:		
	Blue(253)	0	0	0	0	0	0	0	0	0	0	0	0	0	0	0	1	1	1	1	1	1	0		
	Blue(254)	0	0	0	0	0	0	0	0	0	0	0	0	0	0	0	1	1	1	1	1	1	0		
	Blue(255)	0	0	0	0	0	0	0	0	0	0	0	0	0	0	0	1	1	1	1	1	1	1		



11. Interface Timing

11.1 Input Signal Characteristics

11.1.1 Digital Parallel RGB Interface (960×240 resolution)

Characteristics	Symbol	Min.	Typ.	Max.	Unit
		24 bit	24 bit	24 bit	
DOTCLK Frequency	fDOTCLK	-	6.5	10	MHz
DOTCLK Period	tDOTCLK	100	154	-	ns
Horizontal Frequency (Line)	fH	-	14.9	22.35	KHz
Vertical Frequency (Refresh)	fV	-	60	90	Hz
Horizontal Back Porch	tHBP	-	68	-	tDOTCLK
Horizontal Front Porch	tHFP	-	20	-	tDOTCLK
Horizontal Data Start Point	tHBP	-	68	-	tDOTCLK
Horizontal Blanking Period	tHBP + tHFP	-	88	-	tDOTCLK
Horizontal Display Area	HDISP	-	320	-	tDOTCLK
Horizontal Cycle	Hcycle	-	408	450	tDOTCLK
Vertical Back Porch	tVBP	-	18	-	Lines
Vertical Front Porch	tVFP	-	4	-	Lines
Vertical Data Start Point	tVBP	-	18	-	Lines
Vertical Blanking Period	tVBP + tVFP	-	22	-	Lines
Vertical Display Area	NTSC	-	240	-	Lines
	PAL		280(PALM=0)		
			288(PALM=1)		
Vertical Cycle	NTSC	-	262	350	Lines
	PAL		313		

11.1.2 SPI Interface

Characteristics	Symbol	Min.	Typ.	Max.	Unit
Serial Clock Frequency	fclk	-	-	20	MHz
Serial Clock Cycle Time	tclk	50	-	-	ns
Clock Low Width	tsl	25	-	-	ns
Clock High Width	tsh	25	-	-	ns
Clock Rising Time	trs	-	-	30	ns
Clock Falling Time	tfl	-	-	30	ns
Chip Select Setup Time	tcss	0	-	-	ns
Chip Select Hold Time	tcsh	10	-	-	ns
Chip Select High Delay Time	tcsd	20	-	-	ns
Data Setup Time	tds	5	-	-	ns
Data Hold Time	tdh	10	-	-	ns



11.2 Waveform

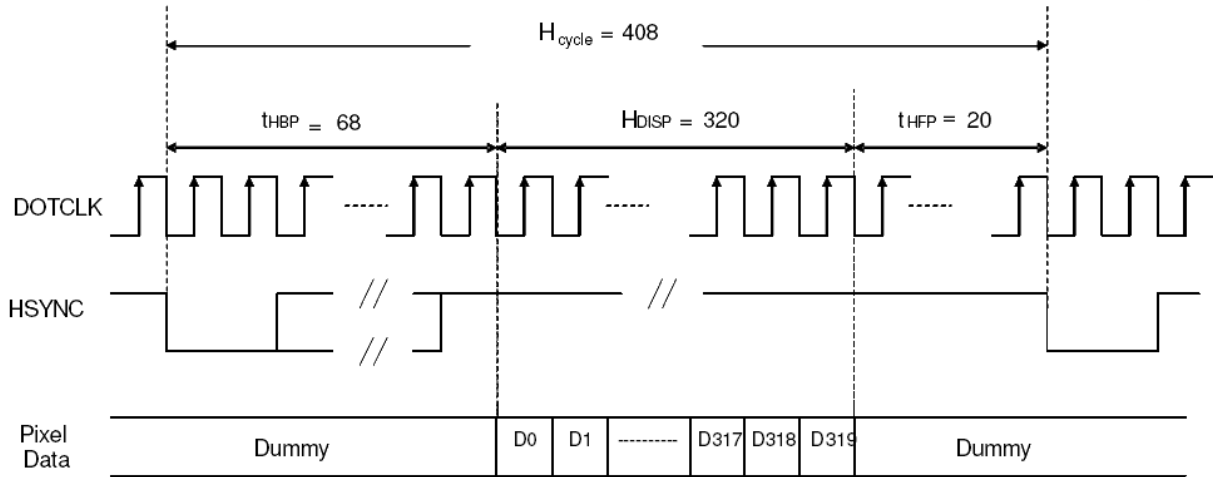

Horizontal Data Transaction Timing

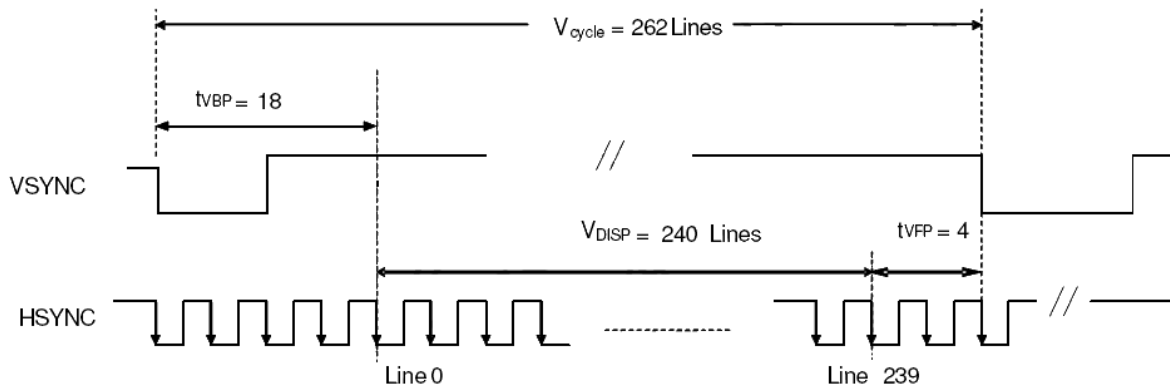

Vertical Data Transaction Timing

Figure 11.2 Data Transaction Timing in Parallel RGB (24 bit) Interface (SYNC Mode)



11.2.1 SPI

R/S	R/W	status
0	0	Write SPI address
1	0	Write SPI data

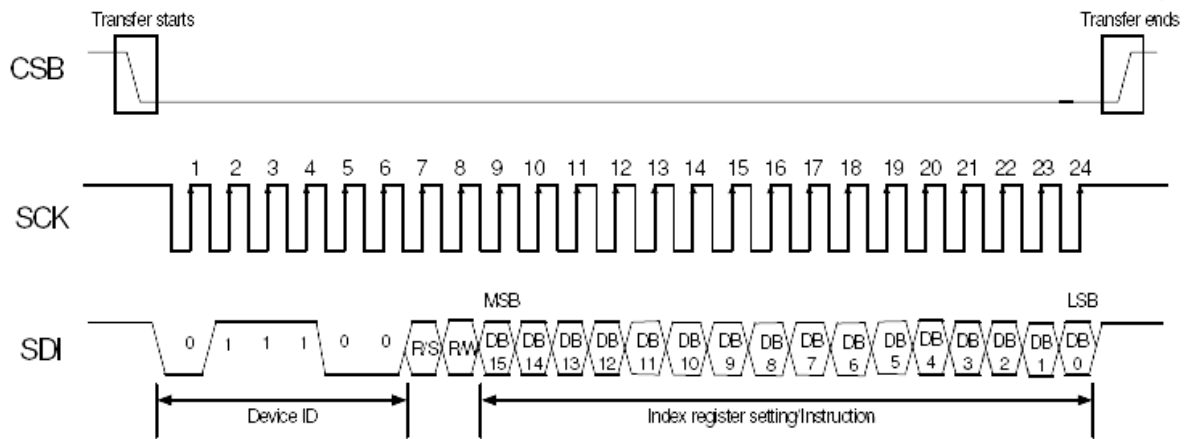

First Transmission (Register)

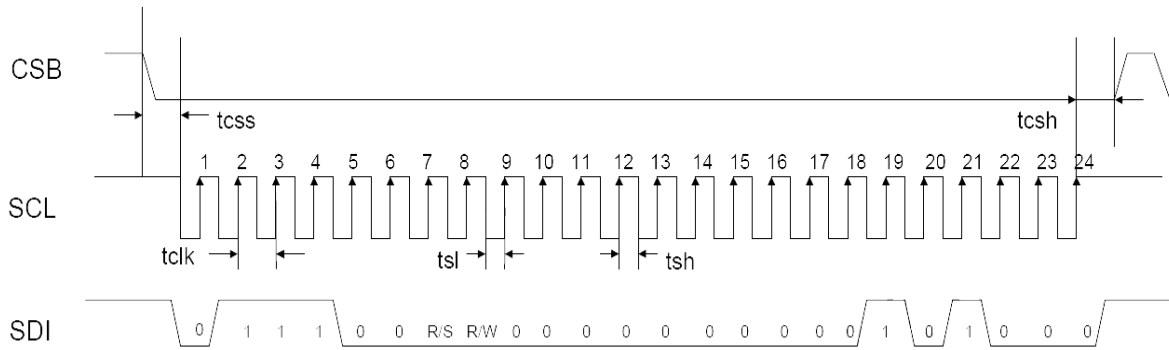

Second Transmission (Data)

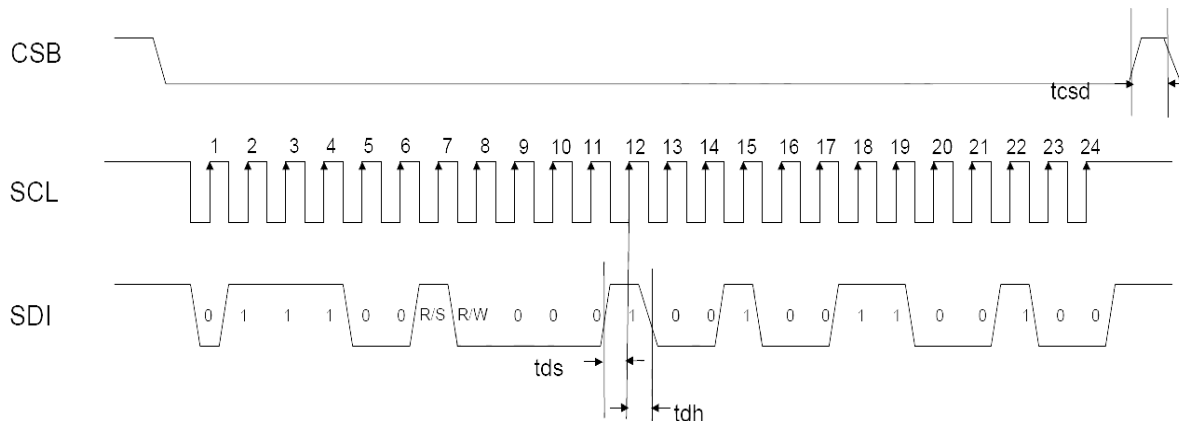



11.3 Power On / Off Sequence

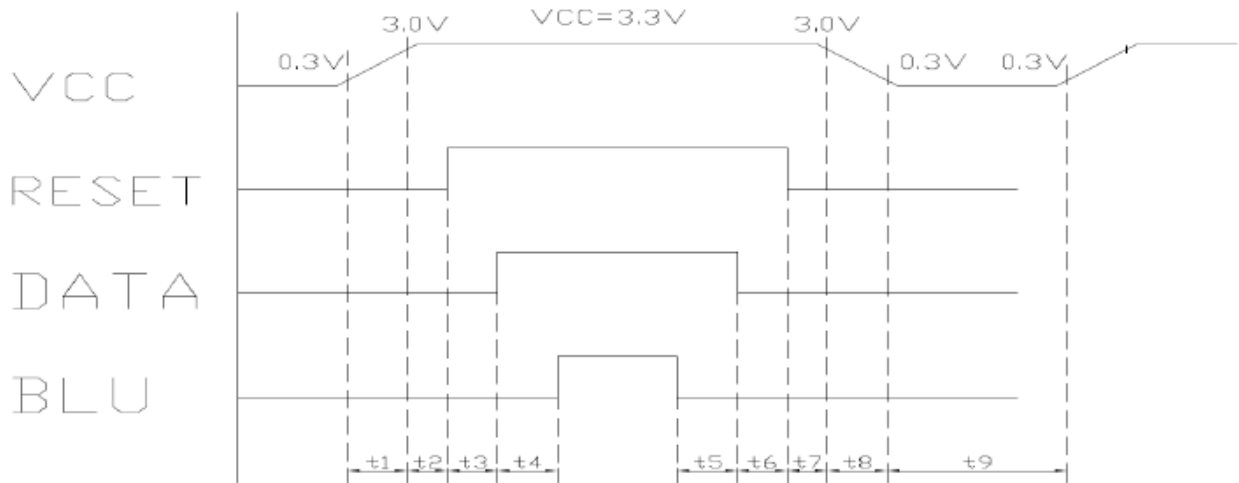

- | | | |
|-------------------|-------------------|-------------------------|
| $T1 \leq 10ms$ | $200ms \leq T5$ | $1 \text{ sec} \leq T9$ |
| $10\mu s \leq T2$ | $50ms \leq T6$ | |
| $50ms \leq T3$ | $10\mu s \leq T7$ | |
| $200ms \leq T4$ | $T8 \leq 10ms$ | |



12. Instruction Description

SPI Command Table

Reg#	Register	R/W	R/S	IB15	IB14	IB13	IB12	IB11	IB10	IB9	IB8	IB7	IB6	IB5	IB4	IB3	IB2	IB1	IB0	
SP	Status Read	1	0	L7	L6	L5	L4	L3	L2	L1	L0	0	0	0	0	0	0	0	0	
R01h	Driver output control	0	1	0	RL	REV	PINV	BGR	SM	TB	CPE	0	0	0	0	0	0	0	0	
R02h	LCD driver AC control	0	1	0	0	0	0	0	0	B/C	0	0	0	0	0	0	0	0	0	
R03h	Power control (1)	0	1	DCT3	DCT2	DCT1	DCT0	BTF	BT2	BT1	BT0	DC3	DC2	DC1	DC0	AP2	AP1	AP0	0	
R04h	Data and color filter control	0	1	0	0	0	0	0	PALM	BLT1	BLT0	OEA1	OEA0	SEL2	SEL1	SEL0	SWD2	SWD1	SWD0	
R05h	Function control	0	1	GHN	XDK	GDIS	LPF	DEP	CKP	VSP	HSP	DEO	DIT	0	PWM	0	FB2	FB1	FB0	
R06h	Reserved	Reserved																		
R07h	Reserved	Reserved																		
R0Ah	Contrast/Brightness control	0	1	0	BR6	BR5	BR4	BR3	BR2	BR1	BR0	0	0	0	CON4	CON3	CON2	CON1	CON0	
R0Bh	Frame cycle control	0	1	NO1	NO0	SDT1	SDT0	0	EQ2	EQ1	EQ0	0	0	0	0	0	0	0	0	
R0Dh	Power control (2)	0	1	0	VRC2	VRC1	VRC0	0	0	VDS1	VDS0	0	0	VRH5	VRH4	VRH3	VRH2	VRH1	VRH0	
R0Eh	Power control (3)	0	1	0	0	1	VDV6	VDV5	VDV4	VDV3	VDV2	VDV1	VDV0	0	0	0	0	0	0	
R0Fh	Gate scan starting Position	0	1	0	0	0	0	0	0	0	0	SCN7	SCN6	SCN5	SCN4	SCN3	SCN2	SCN1	SCN0	
R16h	Horizontal Porch	0	1	XLIM8	XLIM7	XLIM6	XLIM5	XLIM4	XLIM3	XLIM2	XLIM1	XLIM0	0	0	0	0	0	0	0	
R17h	Vertical Porch	0	1	STH1	STH0	HBP6	HBP5	HBP4	HBP3	HBP2	HBP1	HBP0	VBP6	VBP5	VBP4	VBP3	VBP2	VBP1	VBP0	
R1Eh	Power control (4)	0	1	0	0	0	0	0	0	0	0	nOTP	VCM6	VCM5	VCM4	VCM3	VCM2	VCM1	VCM0	
R27h	Reserved	Reserved																		
R28h	Reserved	Reserved																		
R29h	Reserved	Reserved																		
R2Bh	Reserved	Reserved																		
R30h	γ control (1)	0	1	0	0	0	0	0	PKP12	PKP11	PKP10	0	0	0	0	0	PKP02	PKP01	PKP00	
R31h	γ control (2)	0	1	0	0	0	0	0	PKP32	PKP31	PKP30	0	0	0	0	0	PKP22	PKP21	PKP20	
R32h	γ control (3)	0	1	0	0	0	0	0	PKP52	PKP51	PKP50	0	0	0	0	0	PKP42	PKP41	PKP40	
R33h	γ control (4)	0	1	0	0	0	0	0	PRP12	PRP11	PRP10	0	0	0	0	0	PRP02	PRP01	PRP00	
R34h	γ control (5)	0	1	0	0	0	0	0	PKN12	PKN11	PKN10	0	0	0	0	0	PKN02	PKN01	PKN00	
R35h	γ control (6)	0	1	0	0	0	0	0	PKN32	PKN31	PKN30	0	0	0	0	0	PKN22	PKN21	PKN20	
R36h	γ control (7)	0	1	0	0	0	0	0	PKN52	PKN51	PKN50	0	0	0	0	0	PKN42	PKN41	PKN40	
R37h	γ control (8)	0	1	0	0	0	0	0	PRN12	PRN11	PRN10	0	0	0	0	0	PRN02	PRN01	PRN00	
R3Ah	γ control (9)	0	1	0	0	0	VRP14	VRP13	VRP12	VRP11	VRP10	0	0	0	0	0	VRP03	VRP02	VRP01	VRP00
R3Bh	γ control (10)	0	1	0	0	0	VRN14	VRN13	VRN12	VRN11	VRN10	0	0	0	0	0	VRN03	VRN02	VRN01	VRN00

Note: * means don't care



13. Optical Characteristics

The optical characteristics should be measured in a dark environment (≤ 1 lux) or equivalent state with the methods shown in Note (4).

Item		Symbol	Conditions	Min.	Typ.	Max.	Unit	Note
Contrast Ratio		CR	$\theta_x=0^\circ, \theta_y=0^\circ$ Viewing Normal Angle	300	(450)	-	-	(2)
Response Time		T_{R+T_F}		-	50	-	ms	(3)
Luminance(Center)		Y		700	(800)	-	cd/m ²	(4)
Brightness uniformity		B _{UNI}		75	(80)	-	%	(5)
Color Chromaticity	Red	R _x		0.570	0.620	0.670	-	(1),(4)
		R _y		0.310	0.360	0.410	-	
	Green	G _x		0.295	0.345	0.395	-	
		G _y		0.535	0.585	0.635	-	
	Blue	B _x		0.090	0.140	0.190	-	
		B _y		0.035	0.085	0.135	-	
	White	W _x	0.250	0.300	0.350	-		
		W _y	0.270	0.320	0.370	-		
Viewing Angle	Horizontal	θ_{x+}	CR \geq 10	55	(70)	-	deg.	
		θ_{x-}		55	(70)	-		
	Vertical	θ_{y+}		40	(55)	-		
		θ_{y-}		50	(70)	-		



Note (1) Definition of Viewing Angle (θ_x, θ_y):

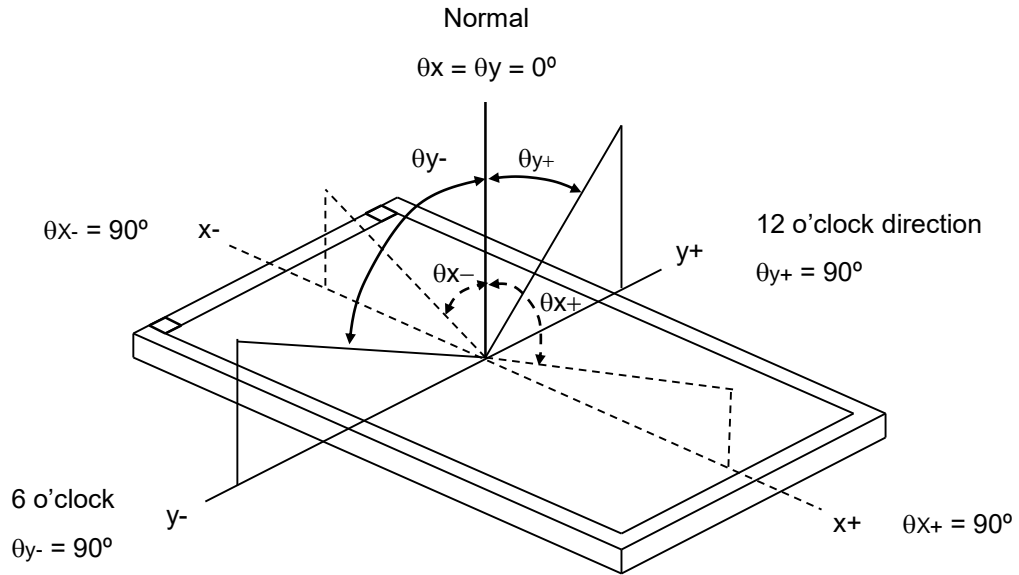

Note (2) Definition of Contrast Ratio (CR):

$$\text{Contrast ratio (CR)} = \frac{\text{Luminance measured when LCD on the "White" state}}{\text{Luminance measured when LCD on the "Black" state}}$$

Note (3) Definition of Response Time (T_R, T_F):

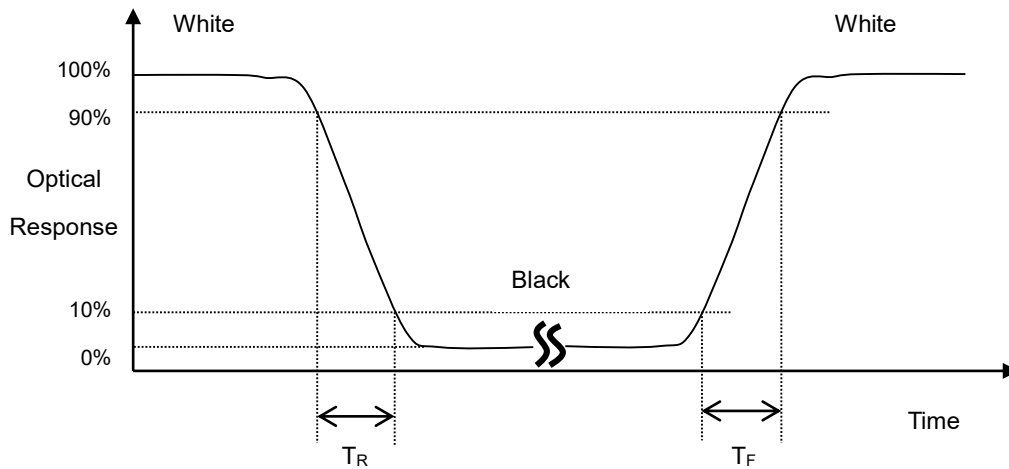



Note (4) Measurement Set-Up:

The LCD module should be stabilized at a given temperature for 30 minutes to avoid abrupt temperature change during measuring. In order to stabilize the luminance, the measurement should be executed after lighting Backlight for 30 minutes in a windless room.

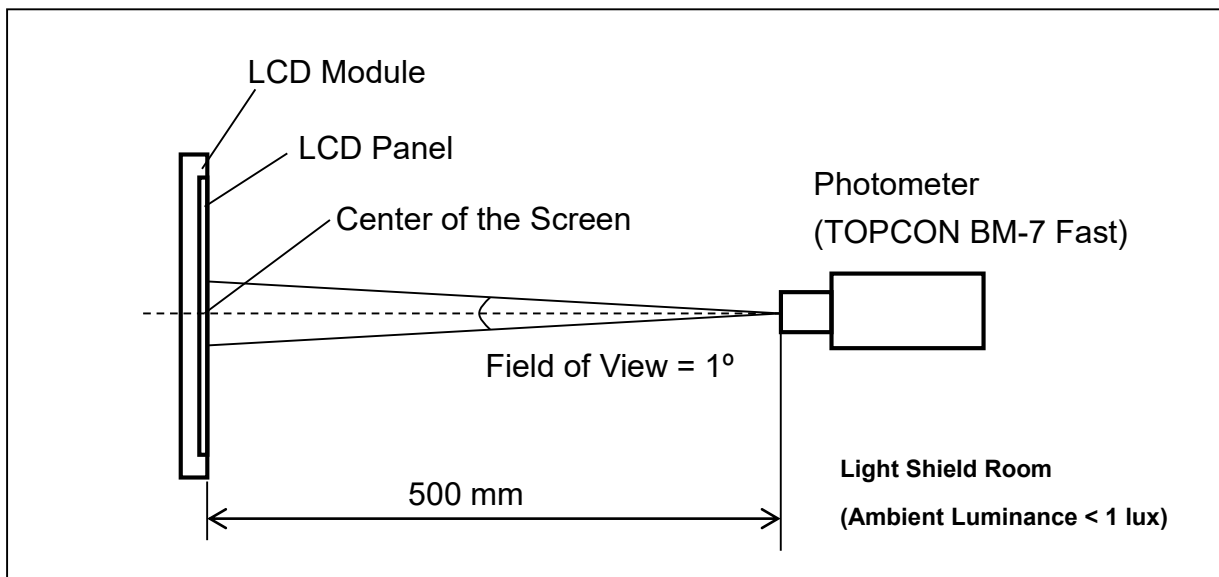

Note (5) Definition of brightness uniformity

$$\text{Brightness uniformity} = (\text{Min Luminance of 9 points}) / (\text{Max Luminance of 9 points}) \times 100\%$$

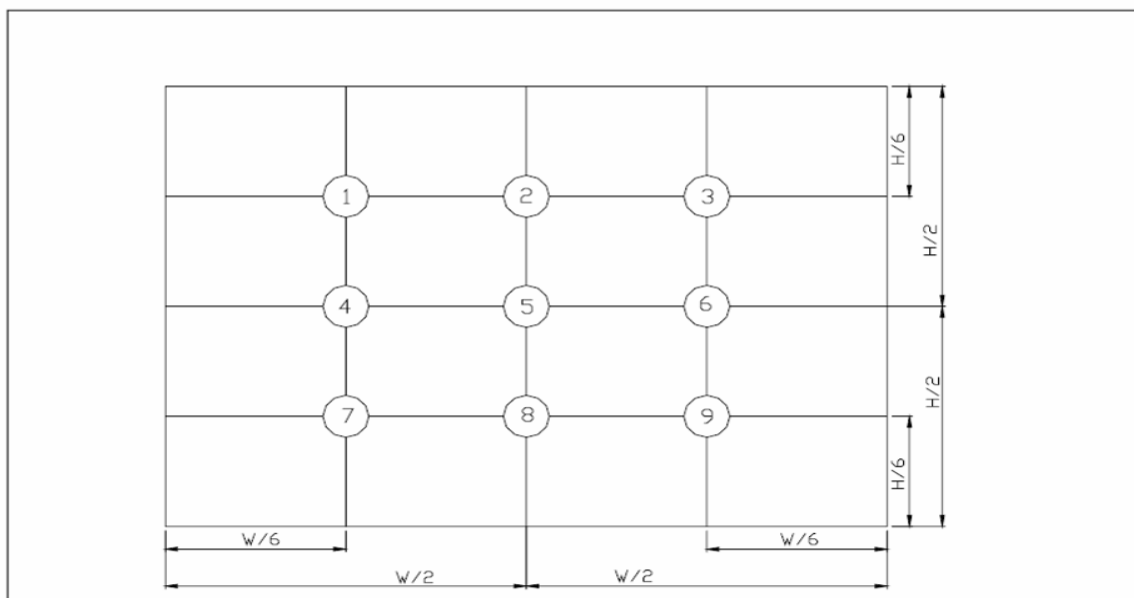

(單位 : mm)

**14. Reliability Test**

No.	Test Items	Test Condition	Remark
1	High Temperature Storage Test	T _a = 80°C 240 hours	(1),(3),(4)
2	Low Temperature Storage Test	T _a = -40°C 240 hours	(1),(3),(4)
3	High Temperature Operation Test	T _s = 80°C 240 hours	(2),(3),(4)
4	Low Temperature Operation Test	T _a = -30°C 240 hours	(1),(3),(4)
5	High Temperature and High Humidity Operation Test	T _a =60°C 90%RH 240 hours	(3),(4)
6	Electro Static Discharge Test (non-operating)	-Panel Surface/Top Case : 150pF, 330Ω Air: ±15kV, Contact: ±8kV	(3)
7	Mechanical Shock Test (non-operating)	Half sine wave, 100G, 6ms 3 times shock of each six surfaces	(3)
8	Vibration Test (non-operating)	Sine wave : 10 ~ 55 ~ 10Hz amplitude : 1.5mm 3 axis , 2 hours/axis	(3)
9	Thermal Shock Test (non-operating)	-20°C(30min) ~ 70°C(30min),100 cycles	(3),(4)
10	Drop Test(with Carton)	Height: 80cm 1 corner, 3 edges, 6 surfaces	(3)

Note 1: T_a is the ambient temperature of samples.

Note 2: T_s is the temperature of panel's surface.

Note 3: In the standard condition, there shall be no practical problem that may affect the display function. After the reliability test, the product only guarantees operation, but don't guarantee all of the cosmetic specification.

Note 4: Before cosmetic and function test, the product must have enough recovery time, at least 2 hours at room temperature.

NOTE5: When OP reaches -30 degree, the reaction of the display will be slower. However, this phenomenon is reversible after the ambient temperature returns to higher values.



15. Packaging

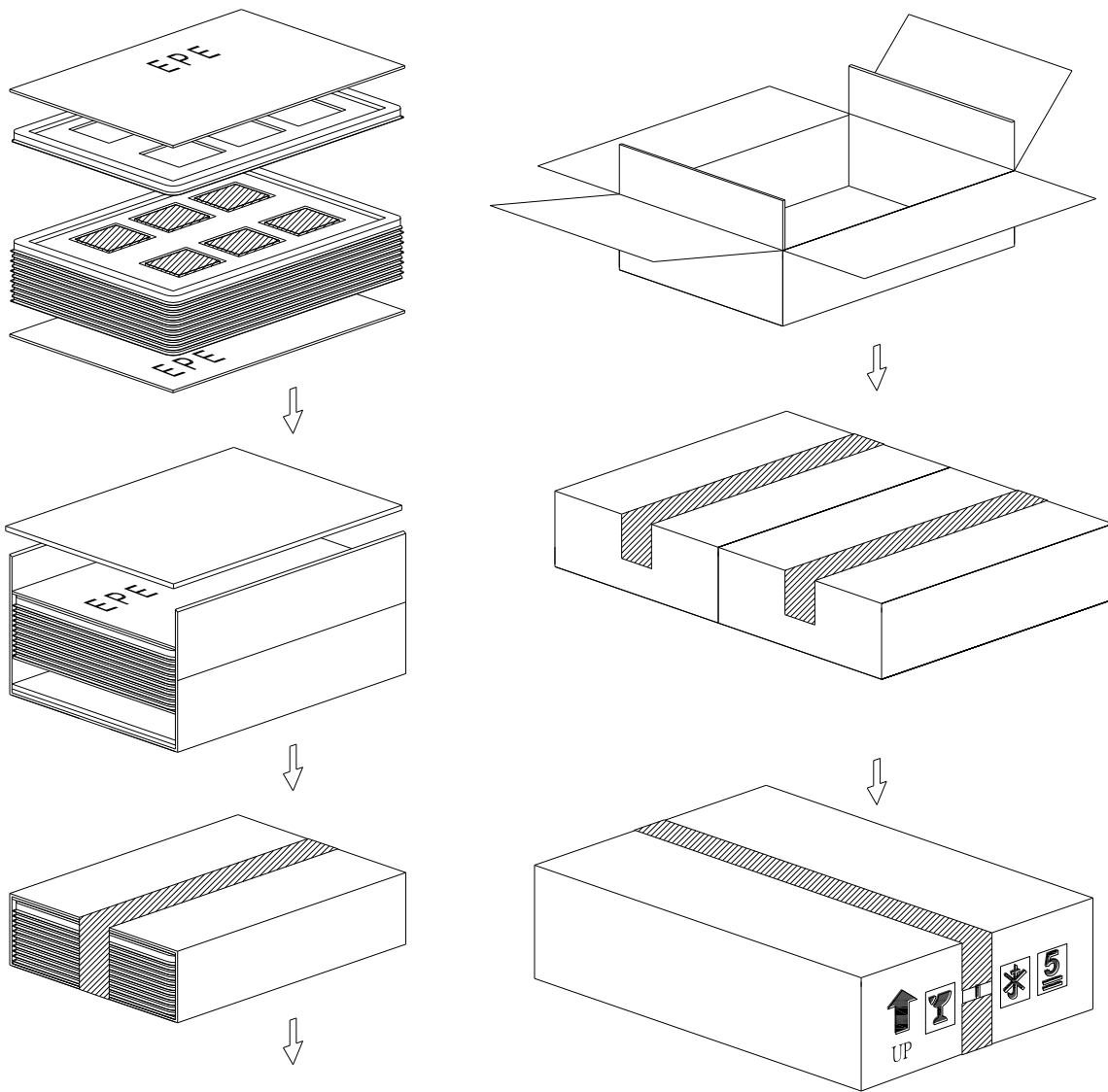

PARTS LIST					
	ITEM	SIZE(LxWxH) unit:mm	MATERIAL	Q.T.Y	NOTE
1	TRAY	372.0x262.0x16.0		28	
2	EPE(J46)	372.0x262.0x5.0	EPE	4	
3	CARD BOARD(P01)	816.0x375.0x3.5	CARTON	2	
4	CARD BOARD(P02)	945.0x275.0x3.5	CARTON	2	
5	CARD BOARD(P03)	375.0x265.0x3.5	CARTON	4	
6	INTERNAL BOX(S01)	400.0x290.0x150.0	CARTON	2	
7	EXTERNAL BOX(L28)	600.0x420.0x180.0		1	
8	PRODUCT	76.9x63.9x3.3		156	



16. Precautions

16.1 Assembly and Handling Precautions

- (1) Do not apply rough force such as bending or twisting to the module during assembly.
- (2) It's recommended to assemble or to install a module into the user's system in clean working areas. The dust and oil may cause electrical short or worsen the polarizer.
- (3) Don't apply pressure or impulse to the module to prevent the damage of LCD panel and Backlight.
- (4) Always follow the correct power-on sequence when the LCD module is turned on. This can prevent the damage and latch-up of the CMOS LSI chips.
- (5) Do not plug in or pull out the I/F connector while the module is in operation.
- (6) Do not disassemble the module.
- (7) Use a soft dry cloth without chemicals for cleaning, because the surface of polarizer is very soft and easily scratched.
- (8) Moisture can easily penetrate into LCD module and may cause the damage during operation.
- (9) High temperature or humidity may deteriorate the performance of LCD module. Please store LCD module in the specified storage conditions.
- (10) When ambient temperature is lower than 10°C, the display quality might be reduced. For example, the response time will become slow.

16.2 Safety Precautions

- (1) If the liquid crystal material leaks from the panel, it should be kept away from the eyes or mouth. In case of contact with hands, skin or clothes, it has to be washed away thoroughly with soap.
- (2) After the module's end of life, it is not harmful in case of normal operation and storage.

16.3 Terms of Warrant

- (1) Acceptance inspection period
The period is within one month after the arrival of contracted commodity at the buyer's factory site.
- (2) Applicable warrant period
The period is within eighteen months since the date of shipping out under normal using and storage conditions.



16.4 Cautions for LCM's installing and assembling

Please keep away the FPC while assembling or fixing the LCM to avoid FPC being damaged or extruded or other related problems. Please see below picture.

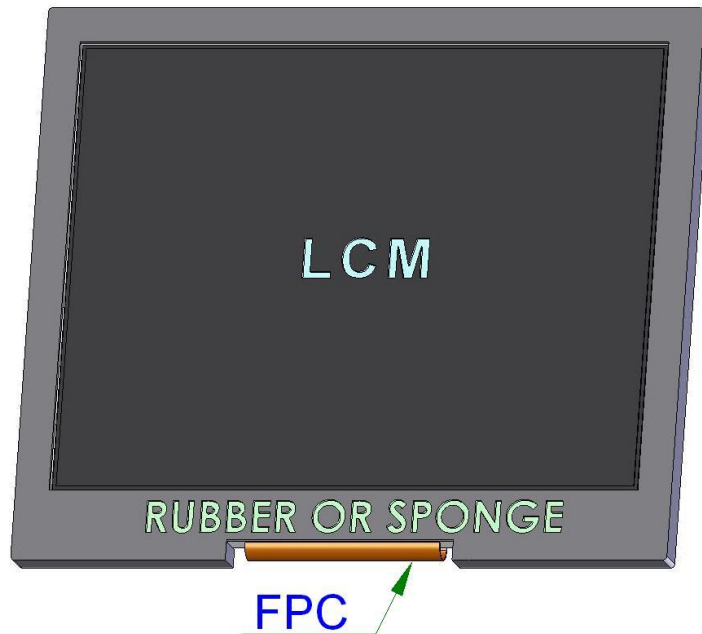



17.Outline Drawing

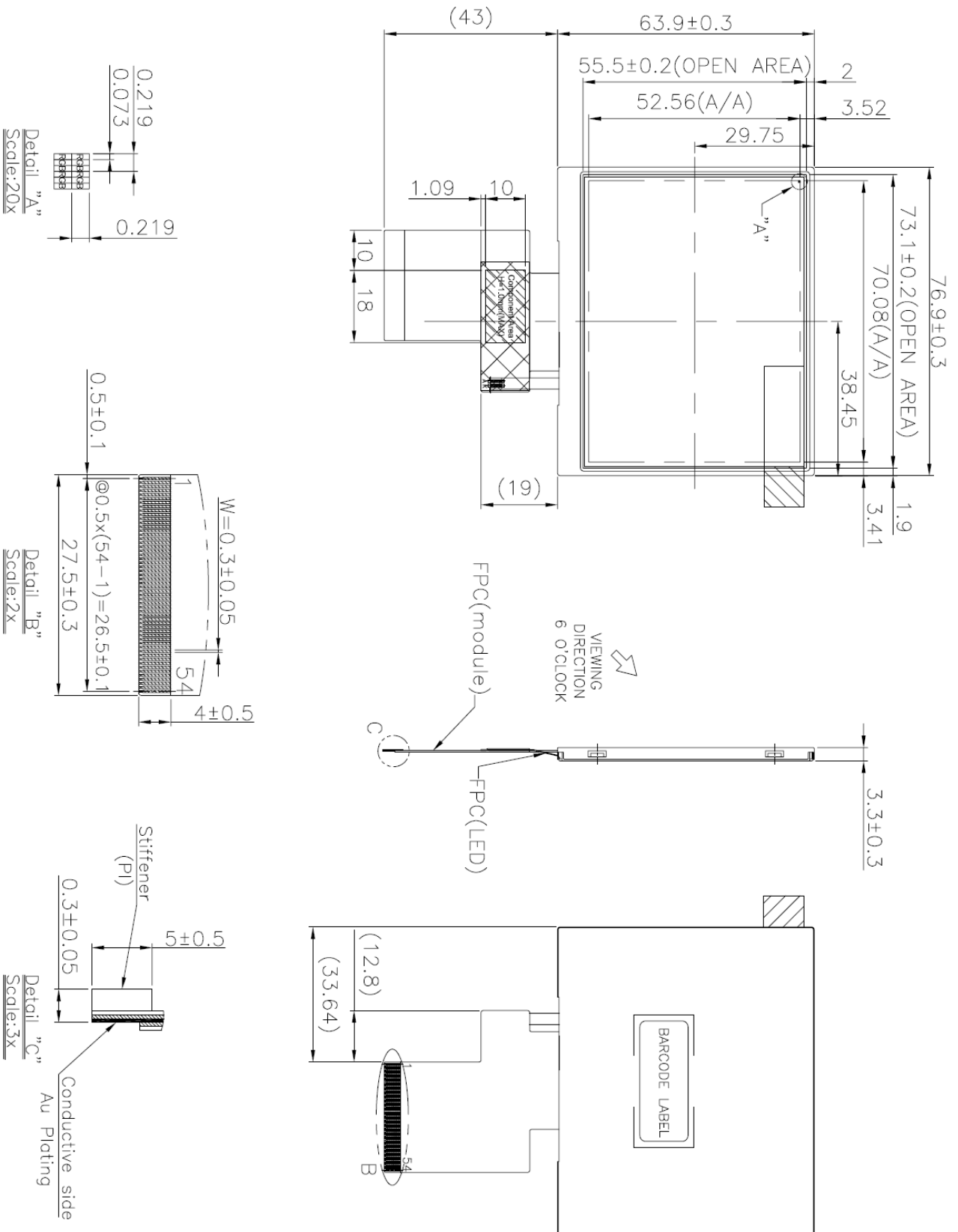



18. Definition of Labels

The bar code nameplate is pasted on each module as illustration, and its definitions are as following explanation.



(a) Module Name: PT322435D-TLMWD-EH25

(b) Serial ID:

A B C D E F G H I J K L M

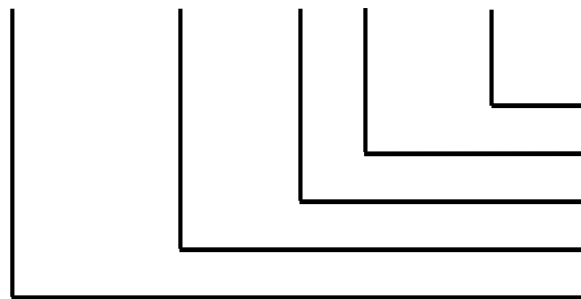

Serial No.
 Revision Code
 Factory Code
 Manufactured Date
 Screen Size

Serial ID includes the information as below:

(a) Screen size (Diagonal): Inch Code (ABCD)

3.5" → 0350

10.4" → 1040

(b) Manufactured Date: Year, Month, Day (EFG)

Year (E)

Year	2000	2001	2002	2003	2004	2005	2006	2007	2008	2009
Mark	0	1	2	3	4	5	6	7	8	9
Year	2010	2011	2012	2013	2014	2015	2016	2017	2018	2019
Mark	A	B	C	D	E	F	G	H	I	J



P-TEC

MODEL NO.

PT322435D-TLMWD-EH25

SPEC & SAMPLE

PAGE

27

Month (F)

Month	Jan.	Feb.	Mar.	Apr.	May	Jun.	Jul.	Aug.	Sep.	Oct.	Nov.	Dec.
Mark	1	2	3	4	5	6	7	8	9	A	B	C

Day (G)

Day	1	2	3	4	5	6	7	8	9	10	11	12	13	14	15	16
Mark	1	2	3	4	5	6	7	8	9	A	B	C	D	E	F	G
Day	17	18	19	20	21	22	23	24	25	26	27	28	29	30	31	
Mark	H	I	J	K	L	M	N	O	P	Q	R	S	T	U	V	

(c) Factory Code (H):

For P-TEC internal use.

(d) Revision Code (I):

Cover all the change, for example: 1: Rev.1, 2: Rev.2, 3: Rev.3...etc.

(e) Serial No. (JKLM):

Manufacturing sequence of product, for example: 0001~9999.



19. Incoming Inspection Standards

19.1 The environmental condition of inspection

The environmental condition and visual inspection shall be conducted as below.

- (1) Ambient temperature $25 \pm 5^{\circ}\text{C}$
- (2) Humidity: $60 \pm 5\%$ RH
- (3) Viewing distance is approximately 35 ~ 40 cm
- (4) Viewing angle is normal to the LCD panel as Fig _1(10°)
- (5) Ambient Illumination: 300 ~ 500 Lux for external appearance inspection

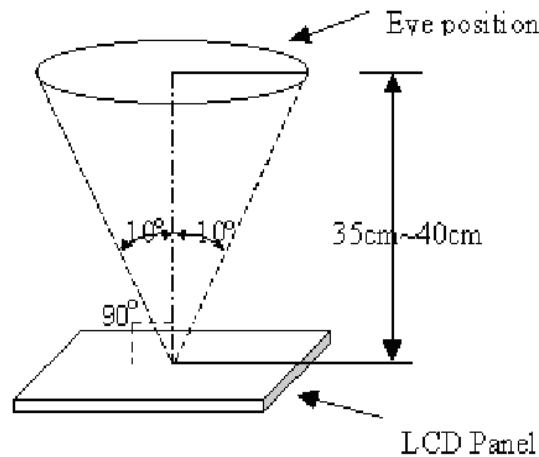

Fig _ 1

19.2 The defects classify of AQL as following:

- (1) Test method :According to [ANSI/ASQC Z 1.4](#) .General Inspection Level II take a single time
- (2) The defects classify of AQL as following:



Class of defects	AQL	Definition
Major	0.65%	It is defect that is likely to result in failure or to reduce materially the usability of the intended function.
Minor	1.5%	It is a defect that will not result in functioning problem with deviation classified.



19.3 Inspection Parameters

Item		Specification/Description			Note	
Display	Function	No Display			-	
		Malfunction			-	
Operating	Contrast ratio	Out of Spec			-	
	Line defect	No obvious Vertical and Horizontal line defect in bright , dark and colored.			-	
	Point Defect (red,green,blue,dark, white)	Item	Acceptable number			Note: 1、4、 5、6
			A	B	Total	
		BRIGHT DOT	$N \leq 0$	$N \leq 2$	$N \leq 6$	
		DARK DOT	$N \leq 2$	$N \leq 4$		
		TOTAL DOT	$N \leq 2$	$N \leq 4$		
TWO ADJACENT DOT		NOT ALLOWED				
THREE OR MORE ADJACENT DOT	NOT ALLOWED					
External Inspection (non-operating)	Scratch on the polarizer	L(mm)	W(mm)	Acceptable number	Note:2	
		$L \leq 2.5$	$W \leq 0.1$	3		
		$L > 2.5$	$W > 0.1$	0		
	Dent or bubble on the polarizer	Dimension(mm)		Acceptable number		Note:3
		$D \leq 0.3$		3		
		$D \leq 0.1$		Disregard		
	Foreign material on the polarizer	Dimension(mm)		Acceptable number		Note:3
		$D \leq 0.5$		2		
		$D \leq 0.1$		Disregard		

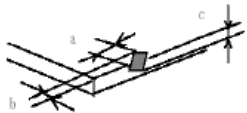
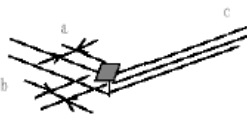

Item		Specification/Description			Note
Touch Panel	Scratch	L(mm)	W(mm)	Acceptable number	Note:2
		L ≤ 10	W < 0.05	Disregard	
			0.05 ≤ W < 0.1	N ≤ 4	
	Foreign Materials (Linear shape)	L ≤ 10	W < 0.05	Disregard	Note:2
			0.05 ≤ W < 0.1	N ≤ 3	
			W ≥ 0.1	0	
	Foreign Materials (Circular shape)	Dimension(mm)		Acceptable number	Note:3
		D ≤ 0.25		Disregard	
		0.25 < D ≤ 0.5		N ≤ 6	
	Glass chipping				a ≤ 5.0mm b ≤ 3.0mm c ≤ t (t : Glass think)
			a ≤ 3.0mm b ≤ 3.0mm c ≤ t (t : Glass think)	Note:7	
Newton-ring	(In case of doubtful situations) Observe on 60° from the product surface under a while Fluorescent lamp (3-wavelength lamp).		Average diameter ≤ 1/3 Touch Panel area Disregard.	Note:7	
Membrane Drum				H ≤ 0.3mm	



Note1. The definition of dot defect : The dot defect was judged after repair and the size of a defective dot over 1/2 of whole dot is regarded as one defective dot.

Note2.

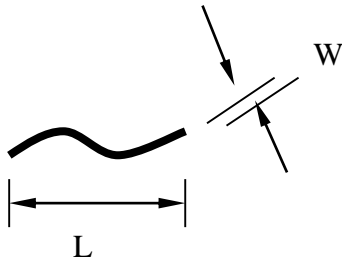

Note3. D : Diameter $D=(a+b)/2$

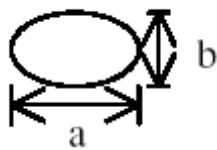

Note4. Bright dot is defined through 6% transmission ND Filter as following.

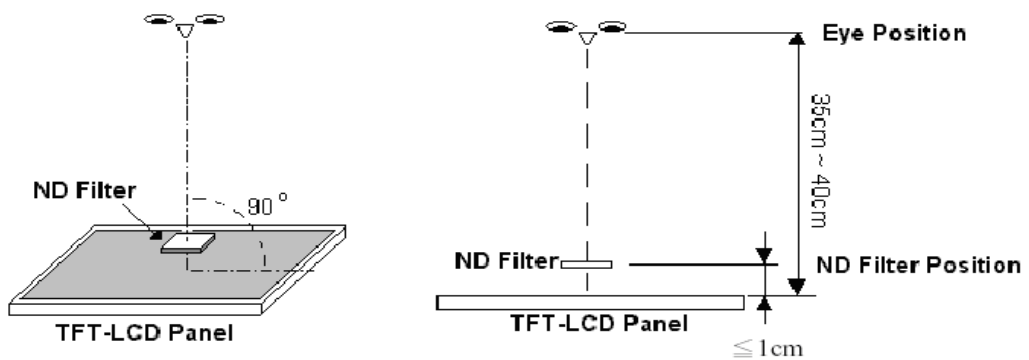

Note5. ADJACENT DOT





Note6.

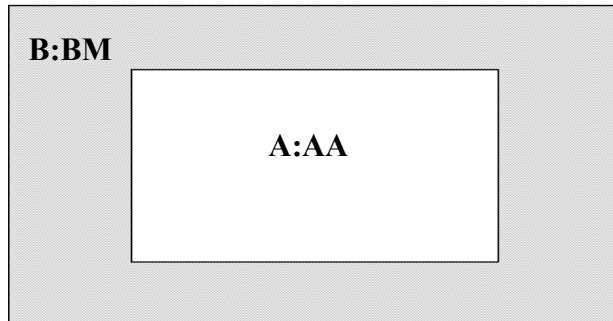

Note7.

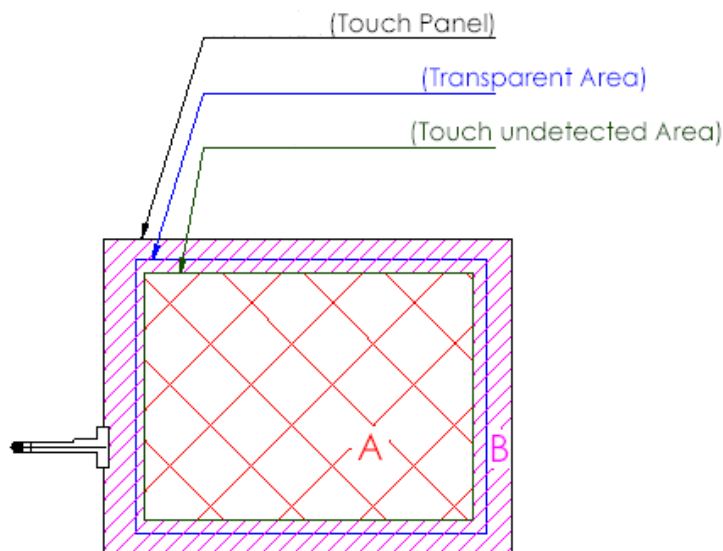

A area : Without any defect point effect on normal operation.

B area : None-specify

19.4 Handling of LCM

- (1) Don't give external shock.
- (2) Don't apply excessive force on the surface.
- (3) Liquid in LCD is hazardous substance. Must not lick and swallow. when the liquid is attach to your hand, skin, cloth etc. Wash it out thoroughly and immediately.
- (4) Don't operate it above the absolute maximum rating.
- (5) Don't disassemble the LCM.