

Motor/Actuator Drivers for DC Brush Motor series

Automotive 2ch 60V Max, H-bridge Drivers

BD16922EFV-M

General Description

The BD16922EFV-M is a 1.0A-output, 2-channel automotive reversible motor driver that allows for operation mode selection from four modes; brake, forward, reverse, and standby, according to two-input logical operation. This motor driver provides high voltage (up to a rating of 60V), low ON resistance, and compact package, thus leading to contribution to enhancing the reliability, reducing the power consumption, and cutting the cost of sets.

Features

- AEC-Q100 Qualified^(Note 1)
- 1 Built-in 1.0A DMOS H Bridge Output 2 Circuit
- 2 Input Control (Stand By, Forward Rotation, Reverse Rotation, Brake)
- Low Standby Current
- Built-in output counter-electromotive force absorption diode
- Built-in Overcurrent Protection Circuit (Detection and Timer) (OCP)
- Built-in Overvoltage Protection (OVP)
- Built-in Thermal Shutdown (TSD)
- Built-in Overcurrent Protection State Output

Terminal (PO)
(Note1 : Grade 2)

Applications^(Note 2)

For Automotive (Air conditioner, and door mirror)

Key Specifications

- Power Supply Voltage 8V to 36V
- Output Current 1.0A (Max)
- Output ON Resistance (Total of upper and lower resistance) 2.25Ω (Typ)
- Operating Temperature Range -40°C to +110°C

Package(s)

HTSSOP-B24

W (Typ) x D (Typ) x H (Max)

7.8mm x 7.6mm x 1.00mm

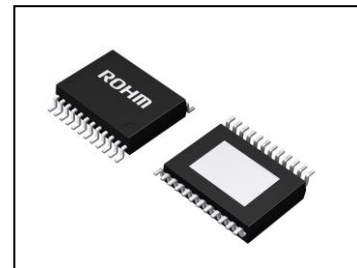

Typical Application Circuit

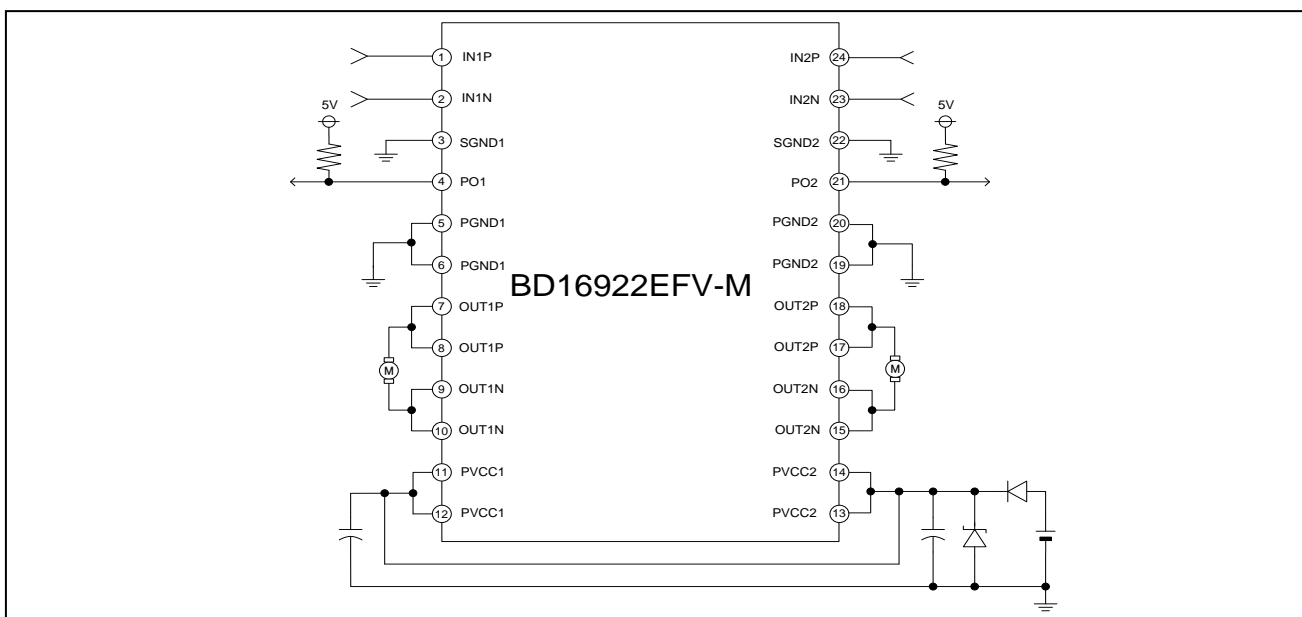

Figure 1. Typical Application Circuit

(Note 2) Please make sure you consult our company sales representative before mass production of this IC, if used other than Door Mirror and HVAC.

○Product structure : Silicon monolithic integrated circuit ○This product has no designed protection against radioactive rays

Pin Configuration

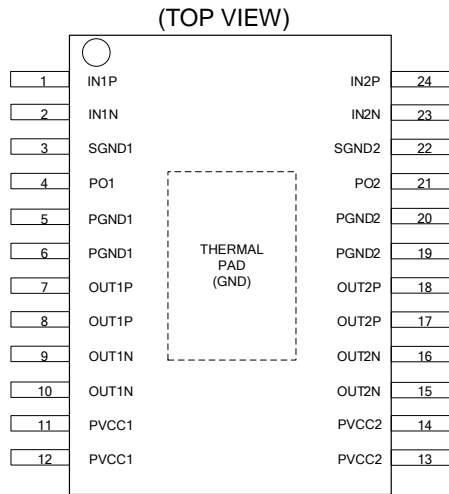

Figure 2. Pin Configuration

Pin Description

Pin No.	Pin Name	Function
1	IN1P	Output state control
2	IN1N	Output state control
3	SGND1	Small signal GND
4	PO1	Output state output (open drain)
5	PGND1	Output part GND
6	PGND1	Output part GND
7	OUT1P	Motor output
8	OUT1P	Motor output
9	OUT1N	Motor output
10	OUT1N	Motor output
11	PVCC1	Power supply
12	PVCC1	Power supply
13	PVCC2	Power supply
14	PVCC2	Power supply
15	OUT2N	Motor output
16	OUT2N	Motor output
17	OUT2P	Motor output
18	OUT2P	Motor output
19	PGND2	Output part GND
20	PGND2	Output part GND
21	PO2	Output state output (open drain)
22	SGND2	Small signal GND
23	IN2N	Output state control
24	IN2P	Output state control

Block Diagram

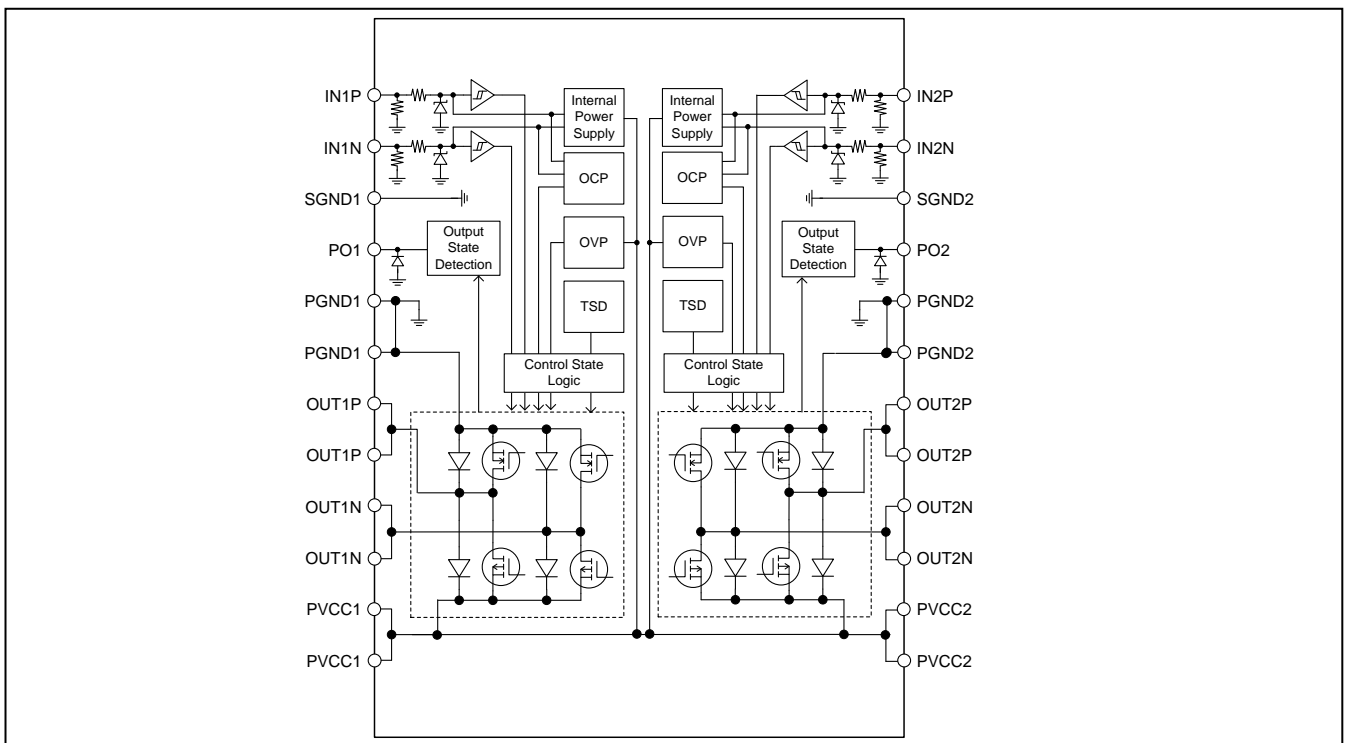

Figure 3. Block Diagram

Absolute Maximum Ratings (Ta=25°C)

Parameter	Symbol	Rating	Unit
Power Supply Voltage (PVCC1,2)	V _{CC}	60	V
Output Voltage (OUT1P, OUT2P, OUT1N, OUT2N)	V _{OUT}	60	V
Input Voltage (PO1,2)	V _{PO}	60	V
Input Voltage (IN1P, IN2P, IN1N, IN2N)	V _{IN}	-0.3 to +20	V
Output Current ^(Note 1)	I _O	1.0	A
Power Dissipation ^(Note 2)	P _d	3.99	W
Operating Temperature Range	T _{opr}	-40 to +110	°C
Storage Temperature Range	T _{stg}	-55 to +150	°C
Junction Temperature	T _{jmax}	150	°C

(Note 1) P_d should not be exceeded

(Note 2) Derating is done 31.9 mW/°C for operating above Ta≥25°C (Mount on 4-layer 70.0mm x 70.0mm x 1.6mm board, ROHM standard board)

Caution: Operating the IC over the absolute maximum ratings may damage the IC. The damage can either be a short circuit between pins or an open circuit between pins and the internal circuitry. Therefore, it is important to consider circuit protection measures, such as adding a fuse, in case the IC is operated over the absolute maximum ratings.

Recommended Operating Conditions (Ta=25°C)

Parameter	Symbol	Min	Typ	Max	Unit
Power Supply Voltage Range ^(Note 1)	V _{CC}	8	12	36	V
Input Voltage Range (IN1P, IN2P, IN1N, IN2N) ^(Note 2)	V _{IN}	-0.3	+5.0	+6.0	V
Output Voltage Range (PO1,2)	V _{PO}	-	5.0	6.0	V

(Note 1) P_d should not be exceeded

(Note 2) In order to start operation while in forward or reverse mode, apply a voltage to all input pins after V_{cc} exceeds the minimum operating voltage range (8V).

Electrical Characteristics (Unless otherwise specified $V_{CC} = 8V$ to $36V$, $T_a = -40^{\circ}C$ to $+110^{\circ}C$)

Parameter	Symbol	Limits			Unit	Conditions	Measurement Circuit ^(Note 1)
		Min	Typ	Max			
Circuit Current 1	I_{CC1}	-	0	10	μA	CH1 & CH2 : $V_{IN} \leq 0.4V$	1
Circuit Current 2	I_{CC2}	-	4	8	mA	CH1 or CH2 : $0.4V < V_{IN}$	1
Circuit Current 3	I_{CC3}	-	8	16	mA	CH1 & CH2 : $0.4V < V_{IN}$	1
Input H Voltage	V_{IH}	3.0	-	-	V		1
Input L Voltage	V_{IL}	-	-	1.0	V		1
Input H Current	I_{IH}	25	50	100	μA	$V_{IN} = 5.0V$, Inflow Current	1
Input L Current	I_{IL}	-	0	10	μA	$V_{IN} = 0.0V$, Outflow Current	1
Output ON Resistance 1	R_{ON1}	-	2.25	3.50	Ω	$I_o = 0.1A$ to $0.8A$, $T_a = -40^{\circ}C$ to $+25^{\circ}C$, Upper and Lower Total	2
Output ON Resistance 2	R_{ON2}	-	3.50	4.50	Ω	$I_o = 0.1A$ to $0.8A$, $T_a = 25^{\circ}C$ to $110^{\circ}C$, Upper and Lower Total	2
Output Leak Current H	I_{LH}	-	0	10	μA	$V_{OUT} = 0V$, Stand-By Mode	3
Output Leak Current L	I_{LL}	-	0	10	μA	$V_{OUT} = V_{CC}$, Stand-By Mode	3
Output Diode Voltage H	V_{FH}	0.2	0.9	1.4	V	$I_o = 0.6A$, $V_{CC} = 0V$, Stand-By Mode	2
Output Diode Voltage L	V_{FL}	0.2	0.9	1.4	V	$I_o = 0.6A$, $V_{CC} = 0V$, Stand-By Mode	2
Protection Output Pin Voltage L	V_{LPO}	-	0.2	0.6	V	$I_{PO} = 3mA$, For Activating the Overcurrent Protection	2
Protection Output Pin Leakage Current	I_{LPO}	-	0	10	μA	$V_{PO} = V_{CC}$, For Activating the Overcurrent Protection	3
Overcurrent Detect Current	I_{OCP}	1.050	1.275	1.550	A		2
Overvoltage Detect Voltage	V_{OVP}	45	50	55	V		1

(Note 1) See pages 15 and 16.

Truth Table

Input		Output		Operating Mode
IN1P, IN2P	IN1N, IN2N	OUT1P, OUT2P	OUT1N, OUT2N	
H	H	L	L	Brake
H	L	H	L	Forward Rotation
L	H	L	H	Reverse Rotation
L	L	Open	Open	Stand-By

Typical Performance Curves (Reference Data)

(Unless otherwise specified $V_{CC} = 8V$ to $36V$, $T_a = -40^{\circ}C$ to $+110^{\circ}C$)

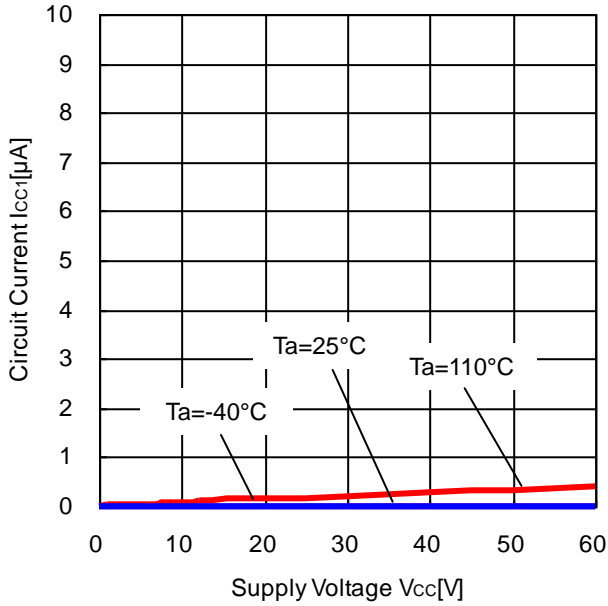

Figure 4. Circuit Current vs Supply Voltage
(Circuit Current 1 I_{CC1} , $V_{CC}=0V$ to $60V$,
 $V_{IN}=0V$ (Stand-By Mode))

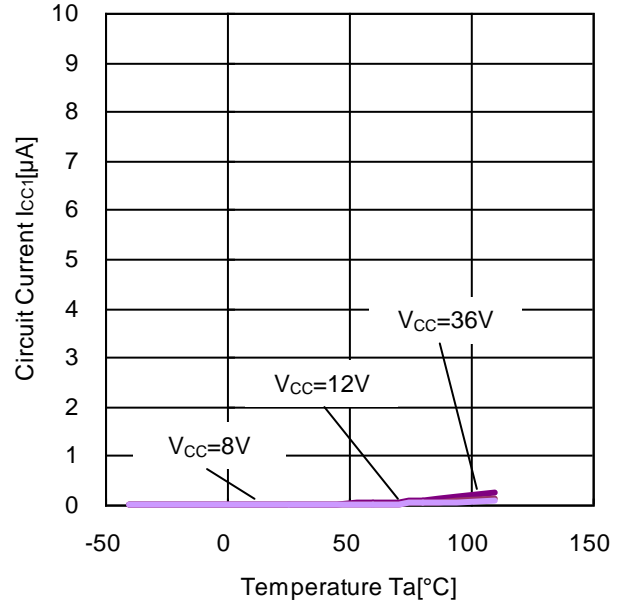

Figure 5. Circuit Current vs Temperature
(Circuit Current 1 I_{CC1} ,
 $V_{IN}=0V$ (Stand-By Mode))

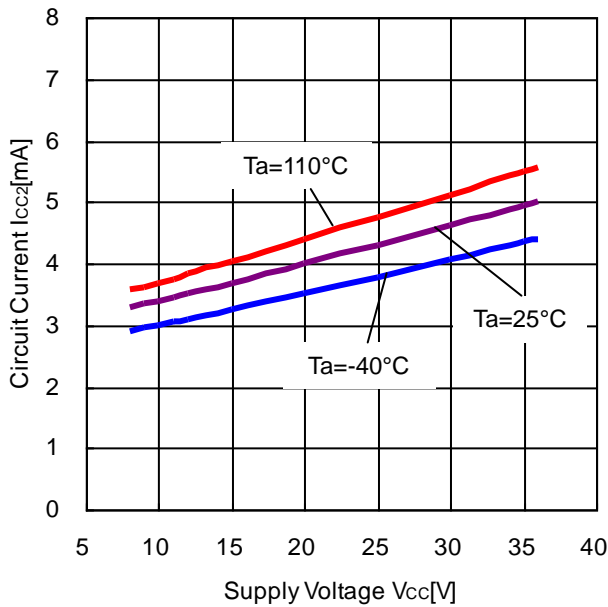

Figure 6. Circuit Current vs Supply Voltage
(Circuit Current 2 I_{CC2} ,
CH1 : $V_{IN}=5.0V$ (Brake Mode),
CH2 : $V_{IN}=0V$ (Stand-By Mode))

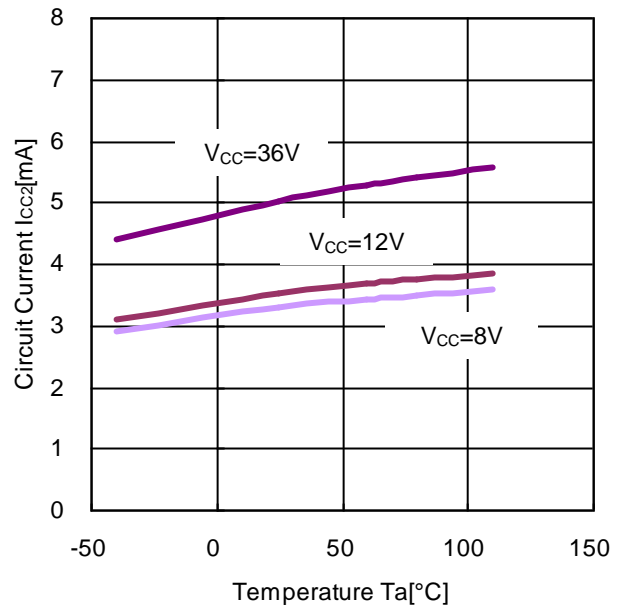

Figure 7. Circuit Current vs Temperature
(Circuit Current 2 I_{CC2} ,
CH1 : $V_{IN}=5.0V$ (Brake Mode),
CH2 : $V_{IN}=0V$ (Stand-By Mode))

Typical Performance Curves (Reference Data) - continued

(Unless otherwise specified $V_{CC} = 8V$ to $36V$, $T_a = -40^{\circ}C$ to $+110^{\circ}C$)

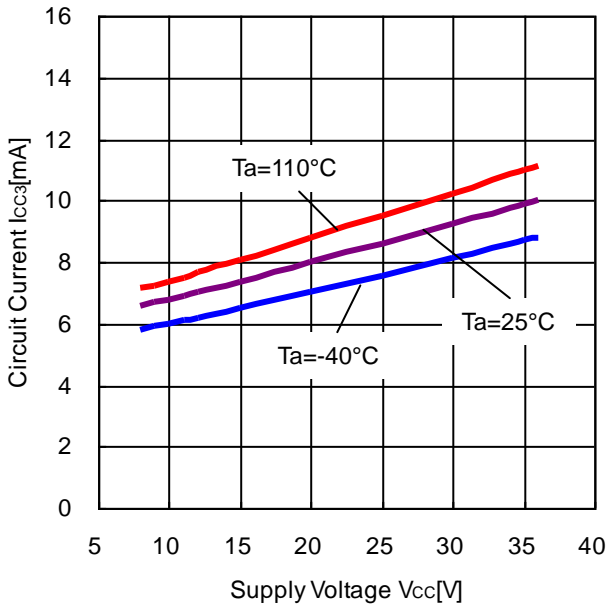

Figure 8. Circuit Current vs Supply Voltage
(Circuit Current 3 I_{CC3} ,
 $V_{IN}=5.0V$ (Brake Mode))

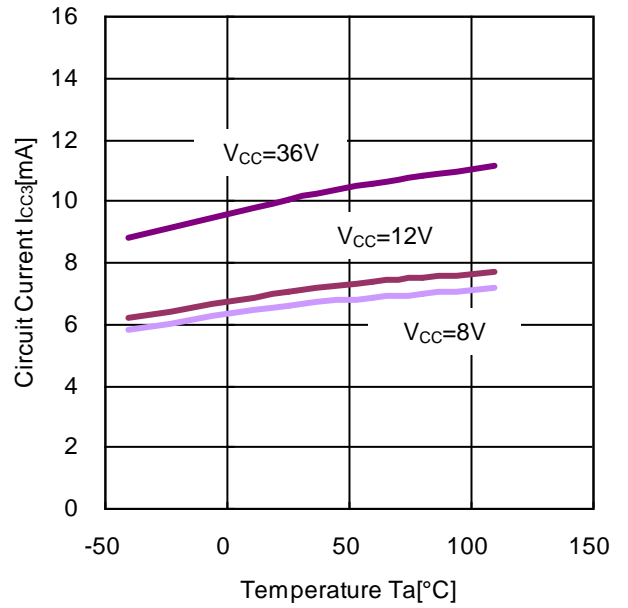

Figure 9. Circuit Current vs Temperature
(Circuit Current 3 I_{CC3} ,
 $V_{IN}=5.0V$ (Brake Mode))

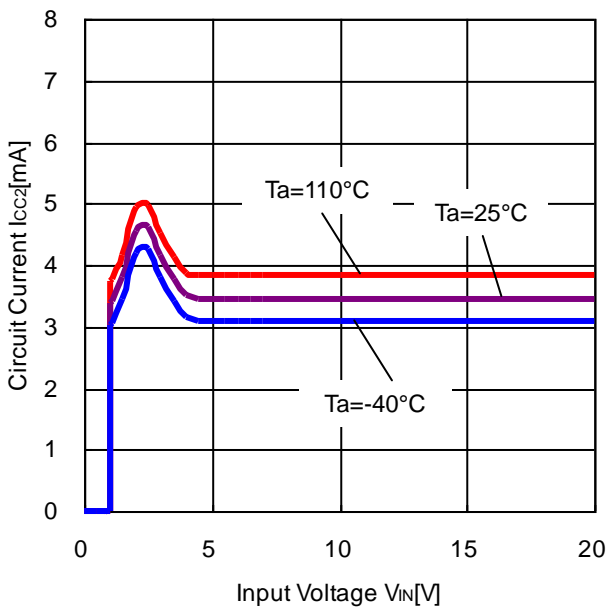

Figure 10. Circuit Current vs Input Voltage
(Circuit Current 2 I_{CC2} , $V_{CC}=12V$)

Typical Performance Curves (Reference Data) - continued

(Unless otherwise specified $V_{CC} = 8V$ to $36V$, $T_a = -40^{\circ}C$ to $+110^{\circ}C$)

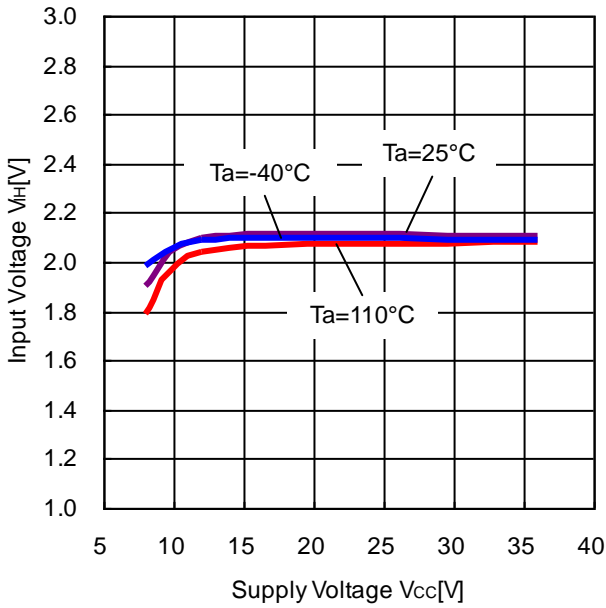

Figure 11. Input Voltage vs Supply Voltage
(Input H Voltage V_{IH} , $V_{IN}=0V \rightarrow 5.0V$)

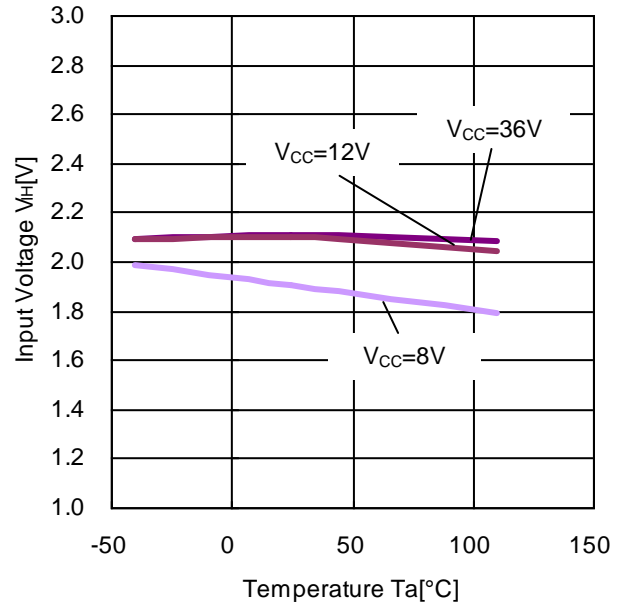

Figure 12. Input Voltage vs Temperature
(Input H Voltage V_{IH} , $V_{IN}=0V \rightarrow 5.0V$)

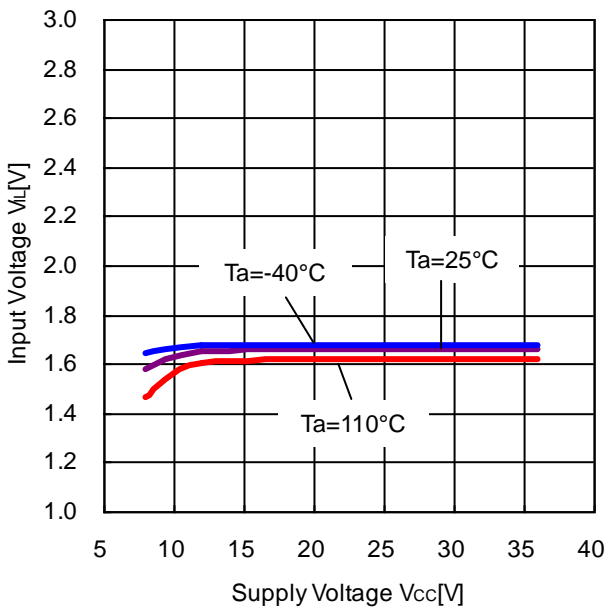

Figure 13. Input Voltage vs Supply Voltage
(Input L Voltage V_{IL} , $V_{IN}=5.0V \rightarrow 0V$)

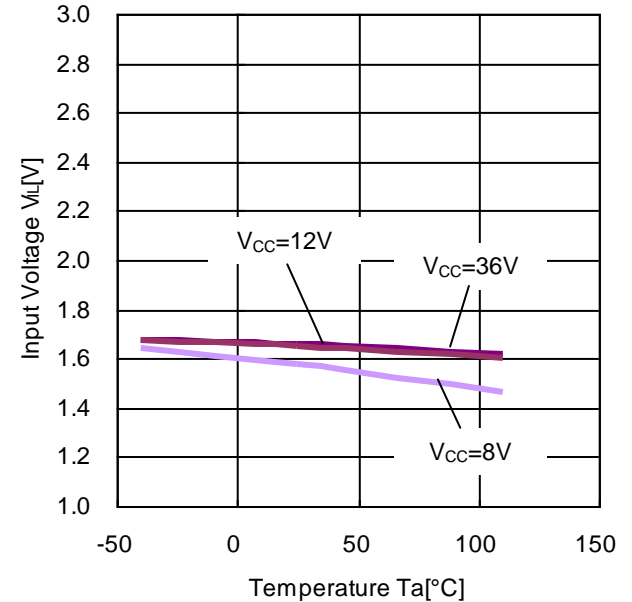

Figure 14. Input Voltage vs Temperature
(Input L Voltage V_{IL} , $V_{IN}=5.0V \rightarrow 0V$)

Typical Performance Curves (Reference Data) - continued

(Unless otherwise specified $V_{CC} = 8V$ to $36V$, $T_a = -40^{\circ}C$ to $+110^{\circ}C$)

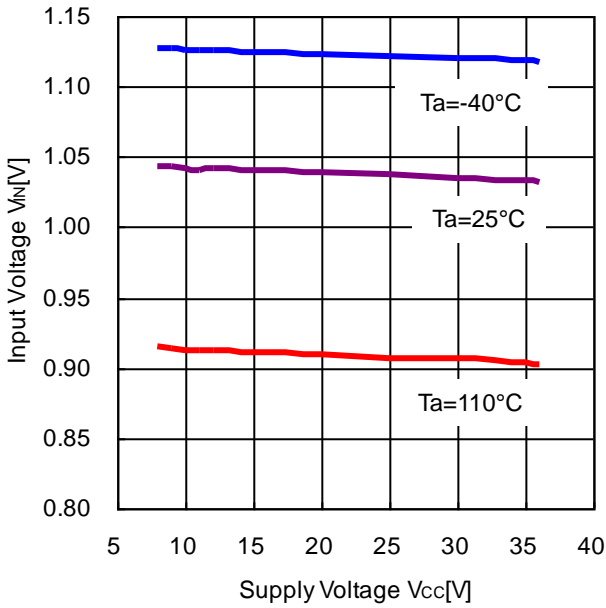

Figure 15. Input Voltage vs Supply Voltage
(Circuit Current Active Voltage, $V_{IN}=0V \rightarrow 5.0V$)

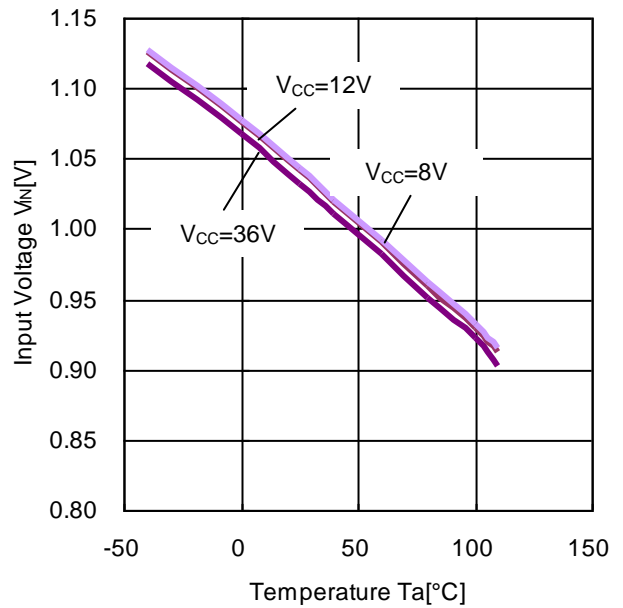

Figure 16. Input Voltage vs Temperature
(Circuit Current Active Voltage, $V_{IN}=0V \rightarrow 5.0V$)

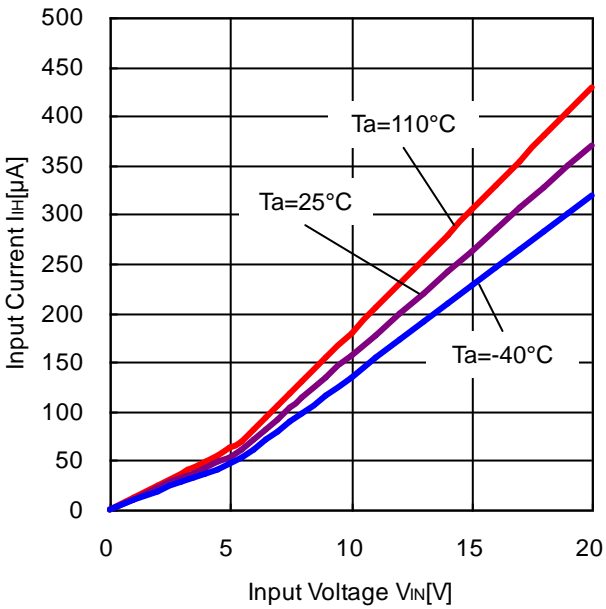

Figure 17. Input Current vs Input Voltage
(Input Current I_{IH} , I_{IL})

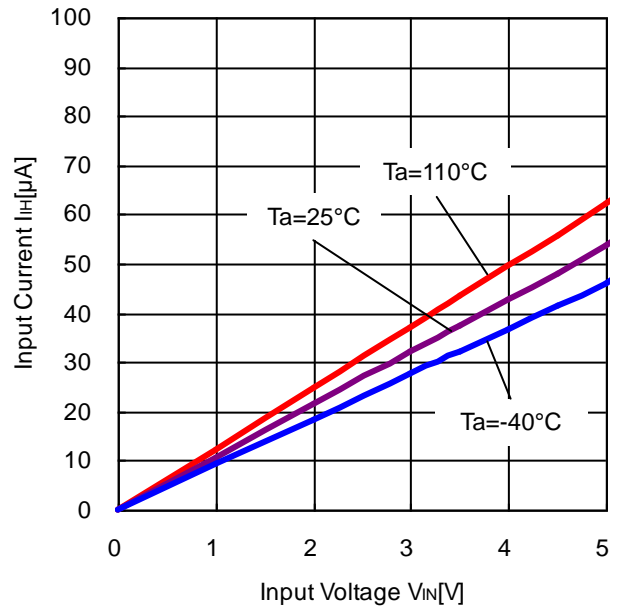

Figure 18. Input Current vs Input Voltage
(Input Current I_{IH} , I_{IL})

Typical Performance Curves (Reference Data) - continued

(Unless otherwise specified $V_{CC} = 8V$ to $36V$, $T_a = -40^\circ C$ to $+110^\circ C$)

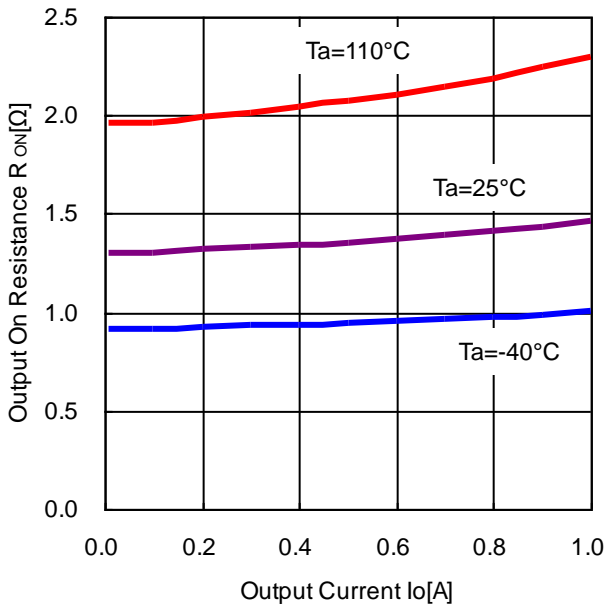

Figure 19. Output On Resistance vs Output Current (Output ON Resistance High Side, $V_{CC}=12V$)

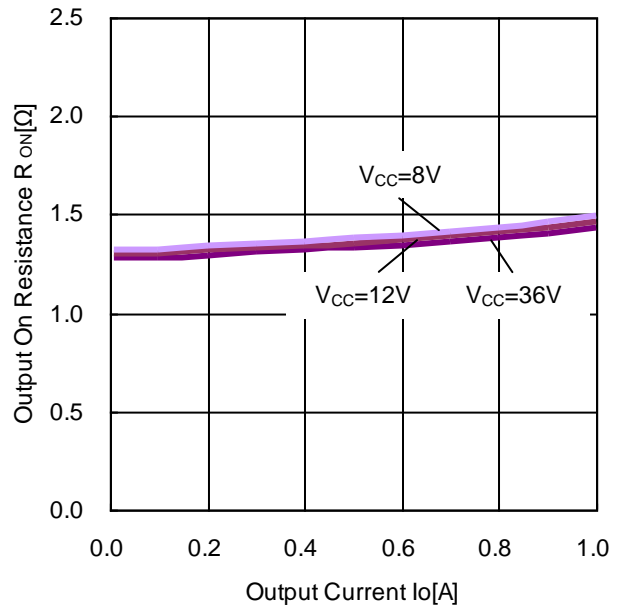

Figure 20. Output On Resistance vs Output Current (Output ON Resistance High Side, $T_a=25^\circ C$)

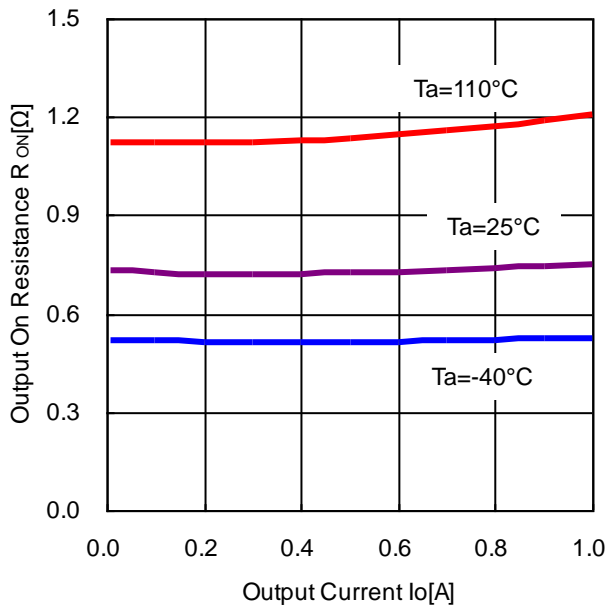

Figure 21. Output On Resistance vs Output Current (Output ON Resistance Low Side, $V_{CC}=12V$)

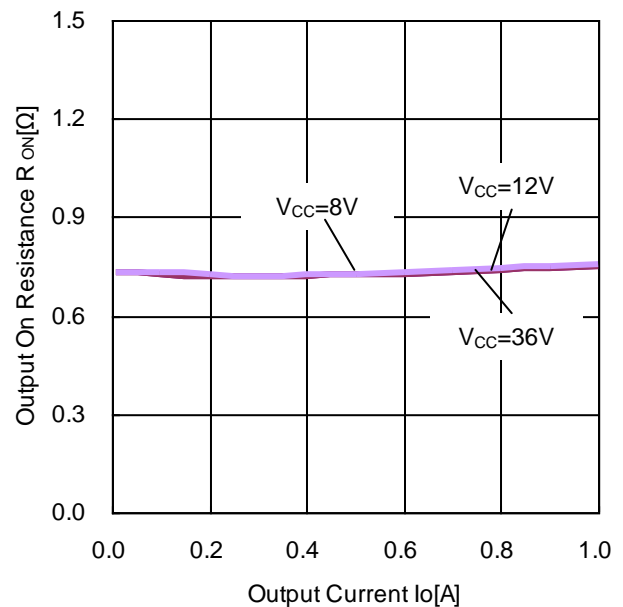

Figure 22. Output On Resistance vs Output Current (Output ON Resistance Low Side, $T_a=25^\circ C$)

Typical Performance Curves (Reference Data) - continued

(Unless otherwise specified $V_{CC} = 8V$ to $36V$, $T_a = -40^{\circ}C$ to $+110^{\circ}C$)

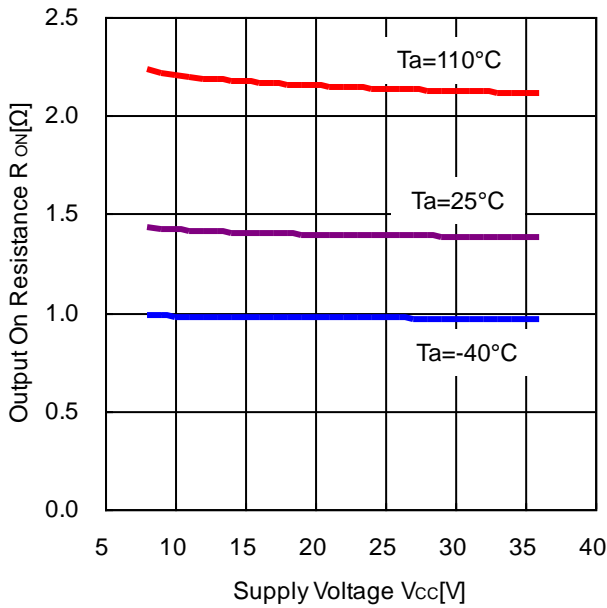

Figure 23. Output On Resistance vs Supply Voltage (Output ON Resistance High Side, $I_o=0.8A$)

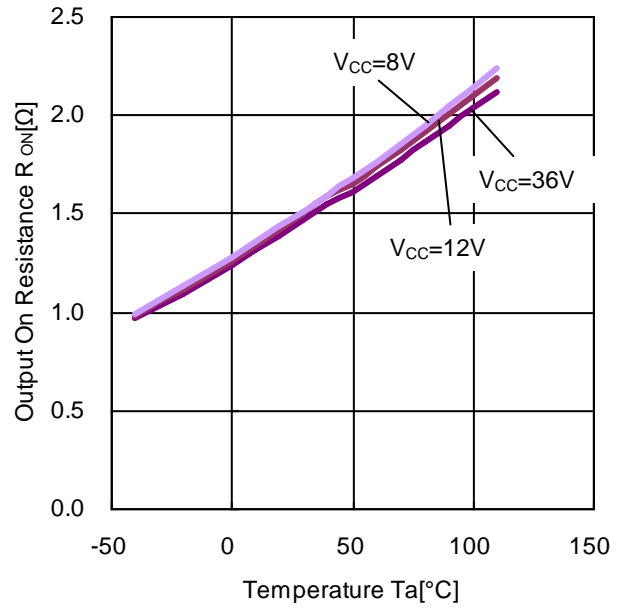

Figure 24. Output On Resistance vs Temperature (Output ON Resistance High Side, $I_o=0.8A$)

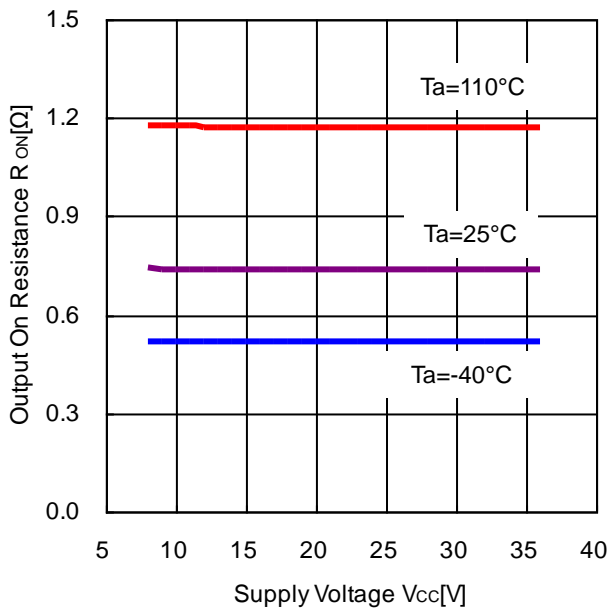

Figure 25. Output On Resistance vs Supply Voltage (Output ON Resistance Low Side, $I_o=0.8A$)

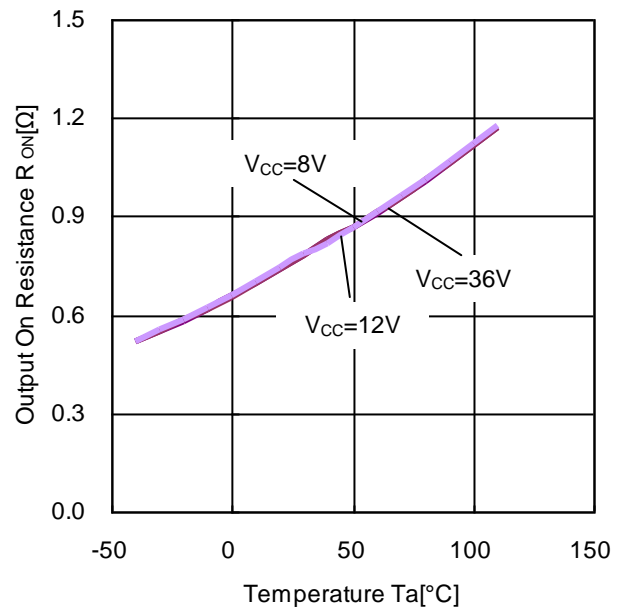

Figure 26. Output On Resistance vs Output Current (Output ON Resistance Low Side, $I_o=0.8A$)

Typical Performance Curves (Reference Data) - continued

(Unless otherwise specified $V_{CC} = 8V$ to $36V$, $T_a = -40^{\circ}C$ to $+110^{\circ}C$)

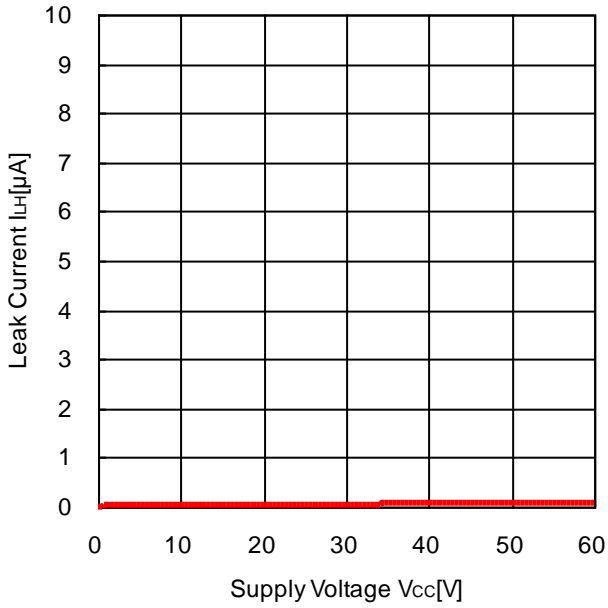

Figure 27. Leak Current vs Supply Voltage
(Output Leak Current High Side I_{LH} , $V_{OUT}=0V$, $T_a=110^{\circ}C$)

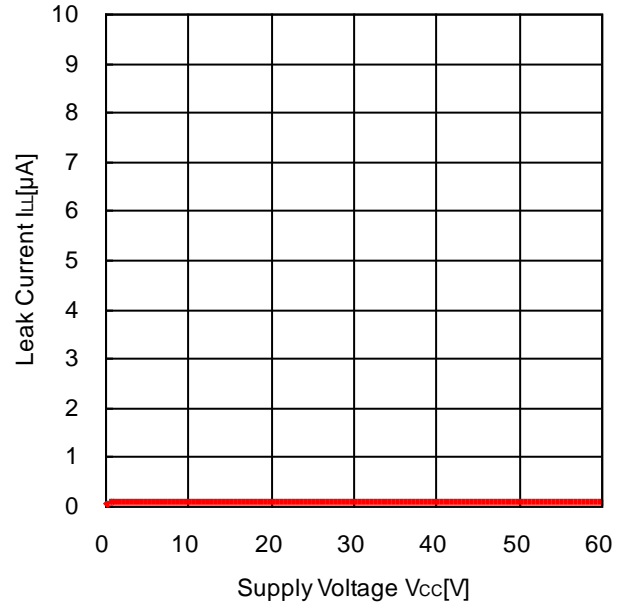

Figure 28. Leak Current vs Supply Voltage
(Output Leak Current Low Side I_{LL} , $V_{OUT}=V_{CC}$, $T_a=110^{\circ}C$)

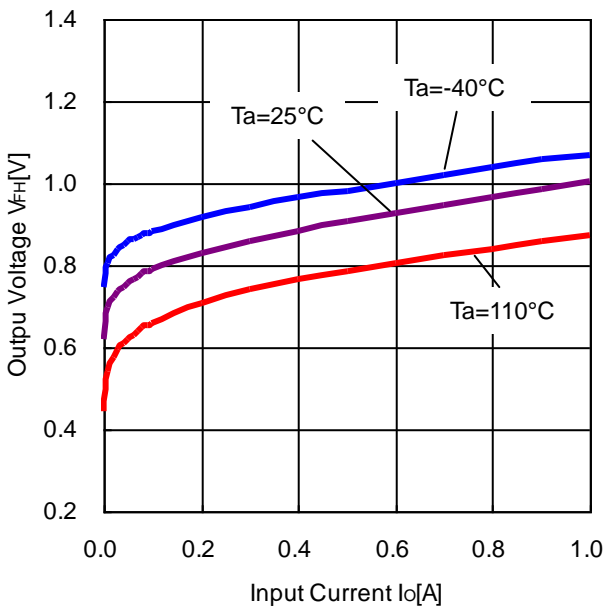

Figure 29. Output Voltage vs Input Current
(Output Diode Voltage High Side V_{FH} , $V_{CC}=0V$)

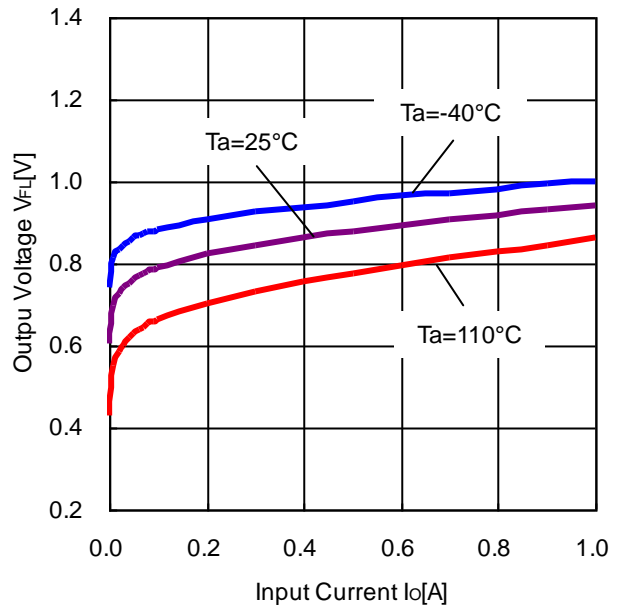

Figure 30. Output Voltage vs Input Current
(Output Diode Voltage Low Side V_{FL} , $V_{CC}=0V$)

Typical Performance Curves (Reference Data) - continued

(Unless otherwise specified $V_{CC} = 8V$ to $36V$, $T_a = -40^{\circ}C$ to $+110^{\circ}C$)

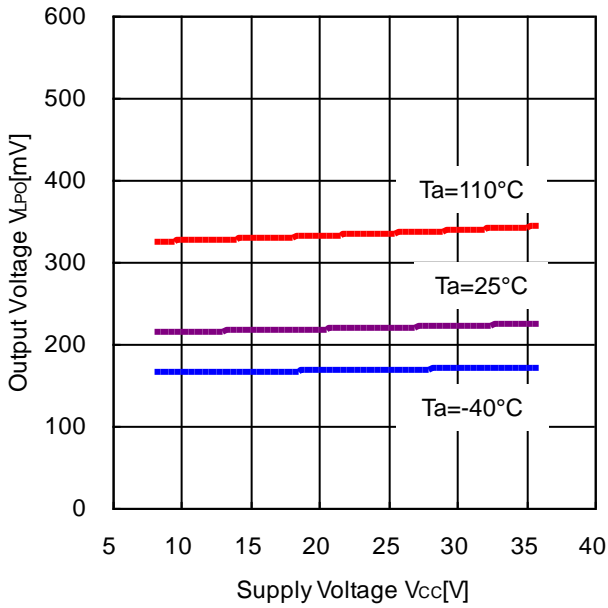

Figure 31. PO Output Voltage vs Supply Voltage
(PO Pin Output Voltage V_{LPO} , $I_{PO}=3mA$,
For Activating the Overcurrent Protection)

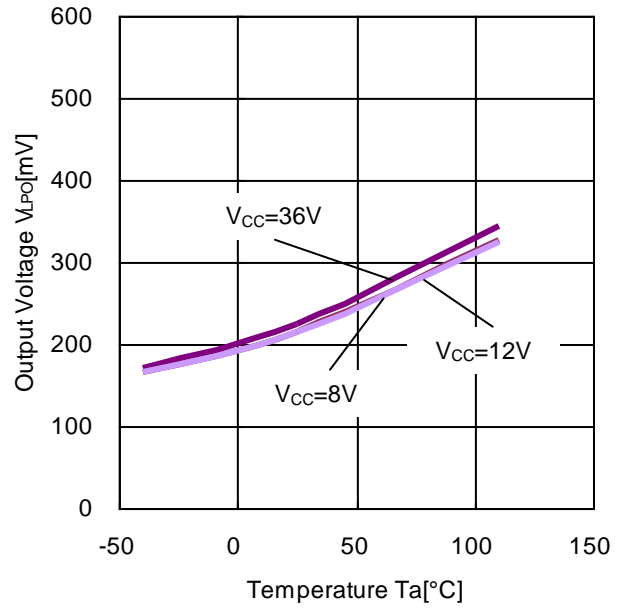

Figure 32. PO output Voltage vs Temperature
(PO Pin Output Voltage V_{LPO} , $I_{PO}=3mA$,
For Activating the Overcurrent Protection)

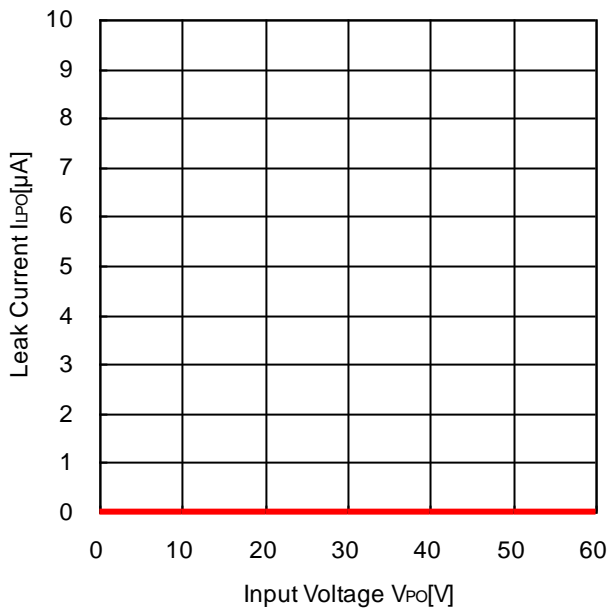

Figure 33. Leak Current vs Input Voltage
(PO Pin Leak Current I_{LPO} , $V_{PO}=V_{CC}$, $T_a=110^{\circ}C$)

Typical Performance Curves (Reference Data) - continued

(Unless otherwise specified $V_{CC} = 8V$ to $36V$, $T_a = -40^{\circ}C$ to $+110^{\circ}C$)

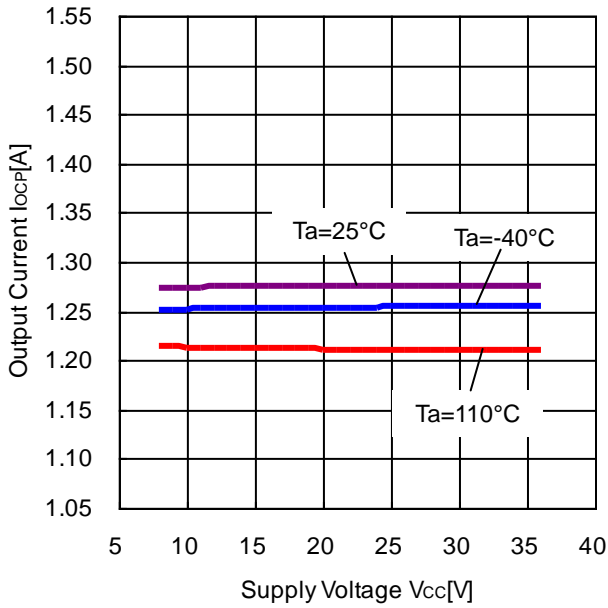

Figure 34. OCP Detect Current vs Supply Voltage (OCP Detect Current High Side I_{OCP} , $I_o=1.05A \rightarrow 1.55A$)

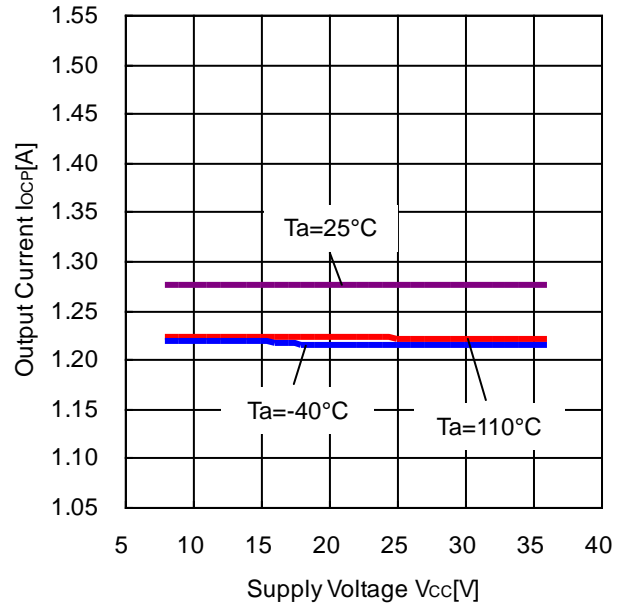

Figure 35. OCP Detect Current vs Supply Voltage (OCP Detect Current Low Side I_{OCP} , $I_o=1.05A \rightarrow 1.55A$)

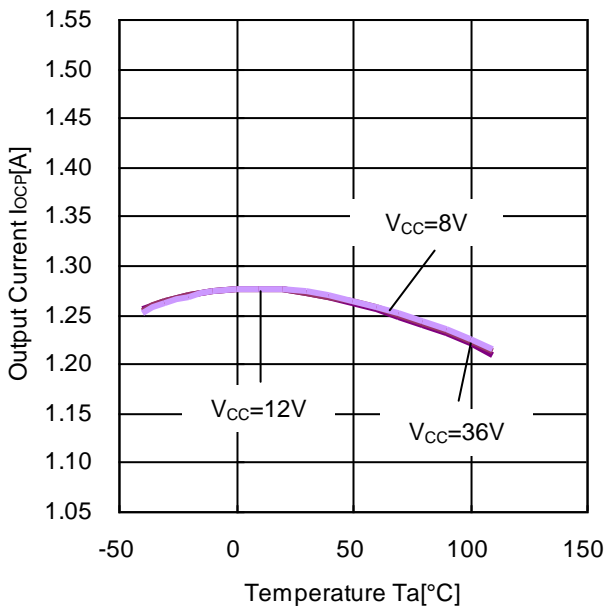

Figure 36. OCP Detect Current vs Temperature (OCP Detect Current High Side I_{OCP} , $I_o=1.05A \rightarrow 1.55A$)

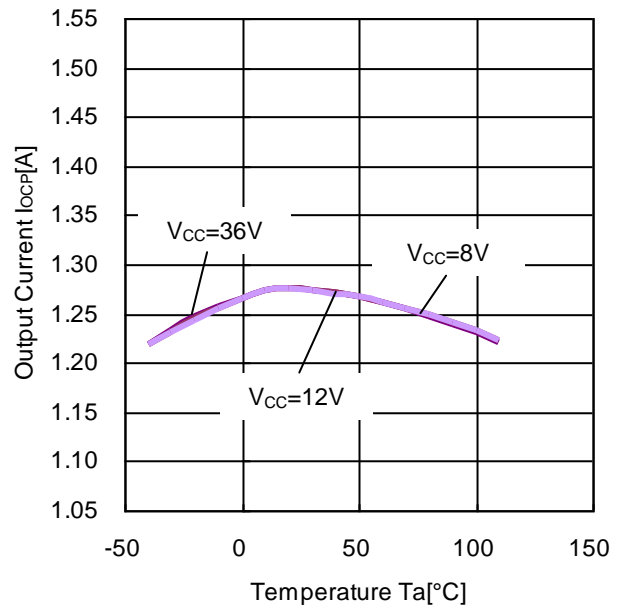

Figure 37. OCP Detect Current vs Temperature (OCP Detect Current Low Side I_{OCP} , $I_o=1.05A \rightarrow 1.55A$)

Typical Performance Curves (Reference Data) - continued

(Unless otherwise specified $V_{CC} = 8V$ to $36V$, $T_a = -40^{\circ}C$ to $+110^{\circ}C$)

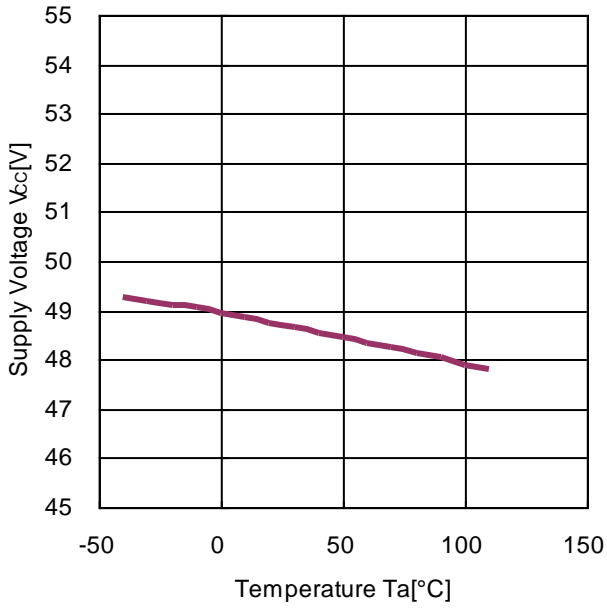

Figure 38. Supply Voltage vs Temperature (OVP Detect Voltage V_{OVP} , $V_{CC}=45V \rightarrow 55V$)

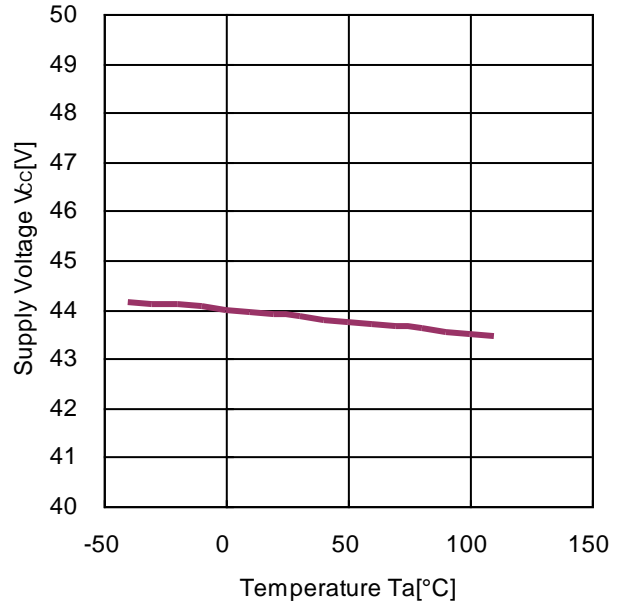

Figure 39. Supply Voltage vs Temperature (OVP Release Voltage, $V_{CC}=50V \rightarrow 40V$)

Typical Performance Curves Measurement Circuits (Reference Data)

(Unless otherwise specified $V_{CC} = 8V$ to $36V$, $T_a = -40^{\circ}C$ to $+110^{\circ}C$)

1. I_{CC1} , I_{CC2} , I_{CC3} , V_{IH} , V_{IL} , I_{IH} , I_{IL} , V_{OVP}

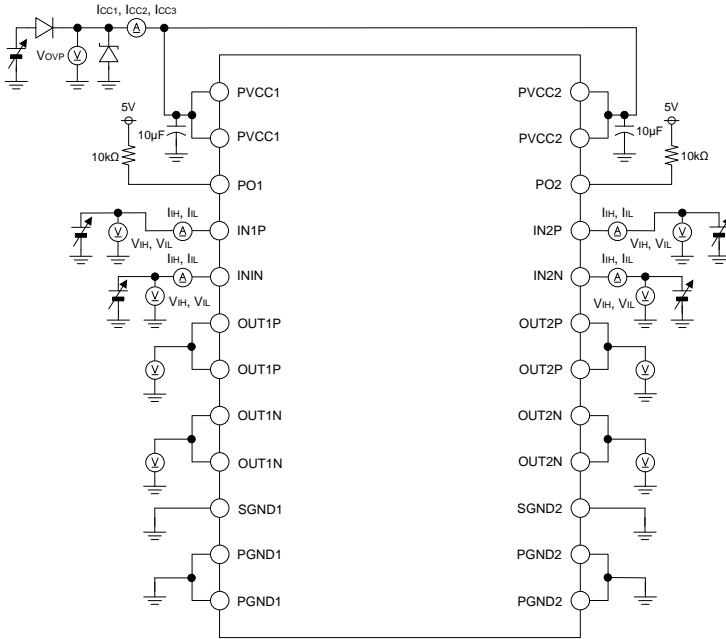

Figure 40. Measurement Circuit 1

- (1) I_{CC1}
 $V_{CC}=0V$ to $60V$, $V_{IN}=0V$
- (2) I_{CC2}
CH1 : $V_{IN}=5.0V$ (Brake Mode),
CH2 : $V_{IN}=0V$
- (3) I_{CC3}
 $V_{IN}=5.0V$ (CH1 & CH2 : Brake Mode)
- (4) V_{IH}
 $V_{IN}=0V \rightarrow 5.0V$,
 V_{IN} for switching the operation mode
- (5) V_{IL}
 $V_{IN}=5.0V \rightarrow 0V$,
 V_{IN} for switching the operation mode
- (6) I_{IH} , I_{IL}
 $V_{CC}=0V$, $V_{IN}=0V$ to $20V$
- (8) V_{OVP}
 $V_{CC}=45V \rightarrow 55V \rightarrow 40V$
 V_{CC} for activating the overvoltage protection

2. R_{ON1} , R_{ON2} , V_{FH} , V_{FL} , V_{LPO} , I_{OCP}

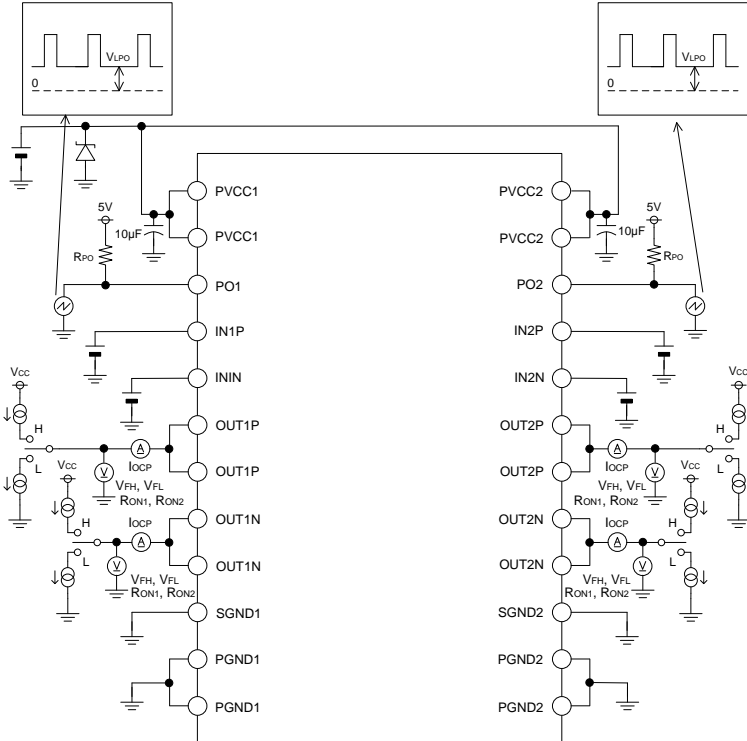

Figure 41. Measurement Circuit 2

- (1) R_{ON1} , R_{ON2}
CH1, CH2 : Forward or Reverse Rotate Mode
 $I_O=0A$ to $1.0A$,
 - High Side
Switch : L
 - Low Side
Switch : H
- (2) V_{FH} , V_{FL}
CH1, CH2 : Stand-By Mode
 $V_{CC}=0V$, $V_{IN}=0.0V$,
 $I_O=0A$ to $1.0A$,
 - V_{FH}
Switch : H
 - V_{FL}
Switch : L
- (3) V_{LPO}
CH1, CH2 : Forward or Reverse Rotate Mode
 $R_{PO}=1.6k\Omega$ ($I_{PO}=3mA$),
 $I_O=1.55A$,
Switch : H or L
- (4) I_{OCP}
CH1, CH2 : Forward or Reverse Rotate Mode
 $R_{PO}=10k\Omega$,
 $I_O=1.05A \rightarrow 1.55A$,
 - High Side
Switch : L
 - Low Side
Switch : H I_O for activating the overcurrent protection

Typical Performance Curves Measurement Circuits (Reference Data) - continued
 (Unless otherwise specified $V_{CC} = 8V$ to $36V$, $T_a = -40^{\circ}C$ to $+110^{\circ}C$)

3. I_{LH} , I_{LL} , I_{LPO}

- (1) I_{LH} , I_{LL}
 $V_{OUT} = 0V \rightarrow 60V$
- (2) I_{LPO}
 $V_{PO} = 0V \rightarrow 60V$

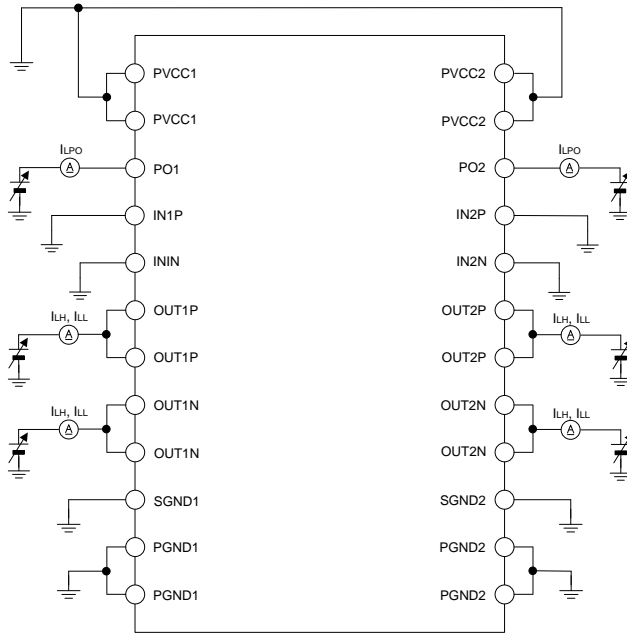

Figure 42. Measurement Circuit 3

Timing Chart

1. Overcurrent Protection (OCP) Timing Chart (INP=H, INN=L, Forward Rotate Mode, Ta=25°C)

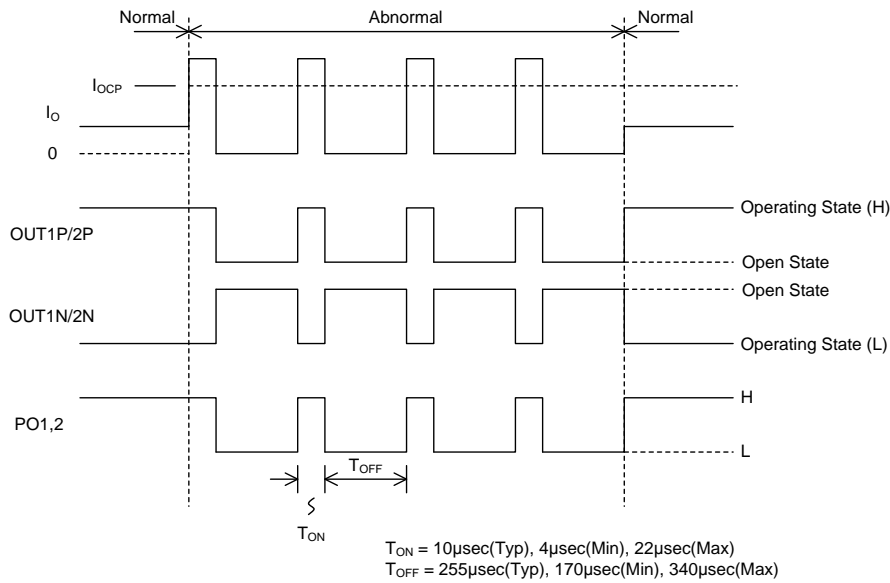

Figure 43. Overcurrent Protection Timing Chart

- (1) The overcurrent protection circuit is designed to conduct protection operation by the channel (i.e., OUT1P&OUT1N or OUT2P&OUT2N).
- (2) The overcurrent protection circuit uses an output voltage detection system (output current × output ON resistance).
- (3) If 1.275A (Typ) or more current passes through the circuit for a period of 10µsec (Typ), the protection circuit will put the output pins into an open state for a period of 255µsec (Typ) and subsequently return to the normal operation. If overcurrent continues to pass through the circuit even after returning to the normal operation, the said protection operation will be repeated.

2. Overvoltage Protection (OVP) Timing Chart (INP=H, INN=L, Forward Rotate Mode, Ta=25°C)

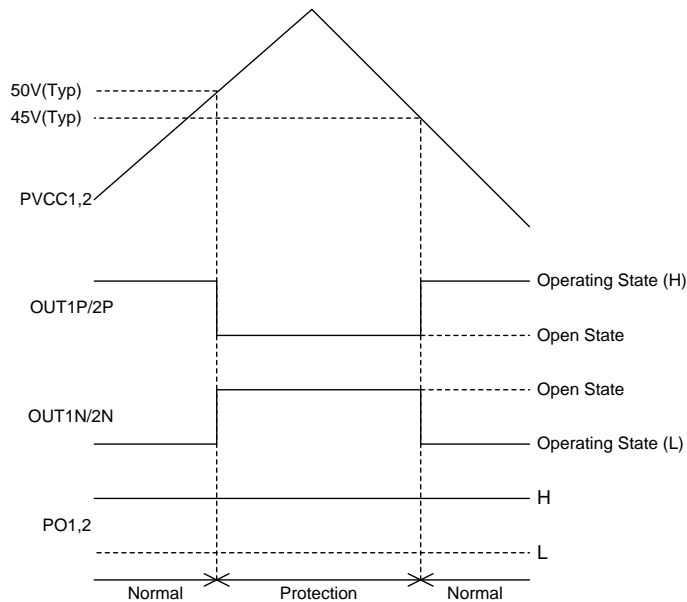

Figure 44. Overvoltage Protection Timing Chart

- (1) The overvoltage protection circuit is designed to conduct protection operation by the channel (i.e., OUT1P&OUT1N or OUT2P&OUT2N).
- (2) If voltage applied to PVCC1 or 2 pin exceeds 50V (Typ), the protection circuit will put the output pins into an open state and if the voltage falls below 45V (Typ), it will return to the normal operation.
- (3) The protection circuit is activated only while in forward, reverse, or brake mode and not activated while in standby mode.
- (4) If power supply voltage exceeds the absolute maximum rating even when the overvoltage protection circuit is activated, the motor driver can break down.

Timing Chart - continued

3. Thermal Shutdown (TSD) Timing Chart (INP=H, INN=L, Forward Rotate Mode)

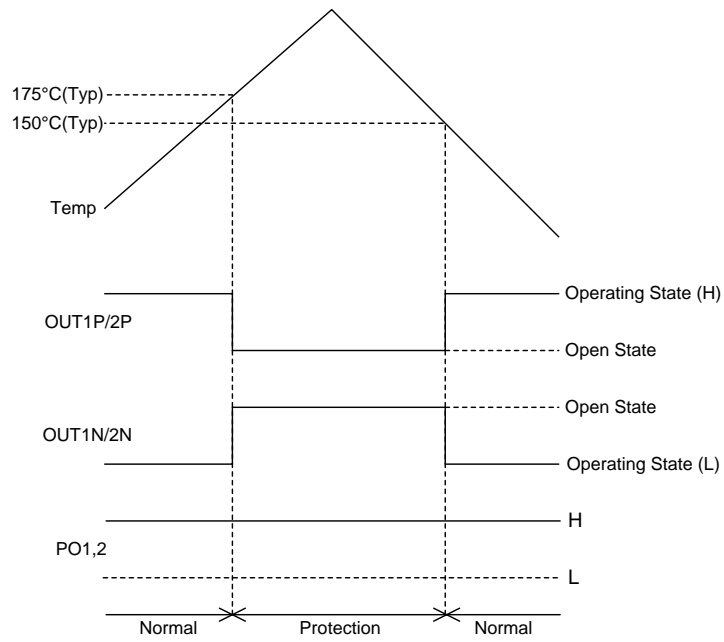

Figure 45. Thermal Shutdown Timing Chart

- (1) The thermal shutdown circuit is designed to conduct protection operation by the channel (i.e., OUT1P&OUT1N or OUT2P&OUT2N).
- (2) If IC chip temperature (Tj) exceeds 175°C (Typ), the circuit will put the output pins into an open state and if the temperature falls below 150°C (Typ), it will return to the normal operation.

Recommended Application Example (Note 1)(Note 2)

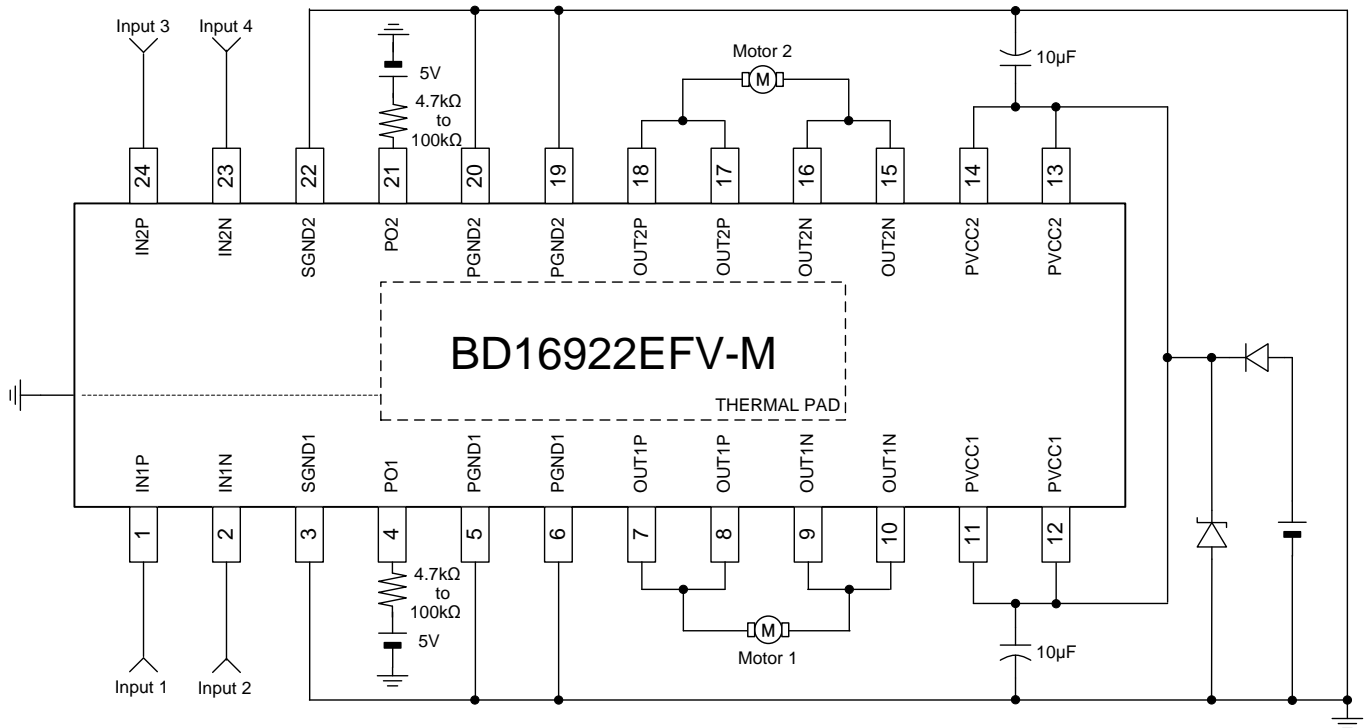

Figure 46. BD16922EFV-M Recommended Application Example

(Note 1) The external circuit constants shown in the diagram above represent a recommended value, respectively.
 (Note 2) The external resistors PO1 and PO2 are a pull-up resistor.

Cautions on Designing of Application Circuits

1. Applicable Motors

Be noted that The BD16922EFV-M motor driver can only drive DC motors and cannot drive stepping motors. Furthermore, in order to use this motor driver for any motors other than automotive motors (for air conditioners and door mirrors), contact your ROHM representative.

2. Use of Only Either One of CH1 and CH2

To use only either one of CH1 and CH2, cause a short circuit between PVCC1 and PVCC2 as shown in Figure 46., and then fix the input not to be used to the L (low) level.

3. PVCC1 and PVCC2

Be sure to mount a power supply decoupling capacitor in the vicinity of the IC pins between the power supply and the ground. Determine the capacitance of the capacitor after fully ensuring that it presents no problems in characteristics. Furthermore, cause a short circuit between PVCC1 and PVCC2 (set them to the same potential) before using the IC.

4. Input Pin Voltage

This IC provides guarantee for circuit operation at input H voltage and input L voltage (see page 4). Using the IC at intermediate potential (with V_{IN} set to 1.0V to 3.0V) may disable the normal operation of any of the protection functions. To avoid that, apply 50mV/μs or more input voltage.

5. Counter-Electromotive Force

The counter-electromotive force may vary with operating conditions and environment, and individual motor characteristics. Fully ensure that the counter-electromotive force presents no problems in the operation or the IC.

6. Fluctuations in Output Pin Voltage

If any output pin makes a significant fluctuation in the voltage to fall below GND potential due to heat generation conditions, power supply, motor to be used, or other conditions, this may result in malfunctions or other failures. In such cases, take appropriate measures, including the addition of a Schottky diode between the output pin and ground.

Cautions on Designing of Application Circuits - Continued**7. Large-Current Lines**

A large current passes through the power supply pins PVCC1 and 2 of the IC motor block and the PGND1 and 2 pins of the motor block. This large current causes backflow depending on board pattern layout or external circuit constants such as the capacitance of the capacitor between the power supply and ground, thus leading to malfunctions, oscillation, or other unfavorable results. To avoid that, layout a board pattern using thick interconnects wherever possible and recommended values like those shown in Figure 46. as external circuit constants, and then fully ensure that the layout presents no problems in characteristics. After that, determine the board pattern layout.

8. Rush Current

This IC has no built-in circuit that limits rush currents caused by applying current to the power supply or switching operation mode. To avoid the rush currents, take physical measures such as adding a current-limiting resistor between PVCC1/2 pins and the power supply.

9. Thermal Pad

Since a thermal pad is connected to the sub side of this IC, connect it to the ground potential. Furthermore, do not use the thermal pad as ground interconnect.

10. Overvoltage Protection

This IC has a built-in overvoltage protection function that protects output pins when overvoltage is applied. If voltage applied to PVCC1 and 2 pins exceeds 50V (Typ), the output pin will open. However, note that this function is only enabled while in forward, reverse, or brake mode and disabled while in standby mode. Furthermore, since the built-in overvoltage protection function may break down if voltage exceeds the absolute maximum rating of power supply voltage, do not apply voltage exceeding the absolute maximum rating.

11. Overcurrent Protection

This IC has a built-in overcurrent protection function that protects it from breakdown when the output pin is short-circuited. Overcurrent protection is a function that protects the IC from breakdown due to short-circuited output pin, but is likely to cause the IC to generate heat or deteriorate if it remains in the overcurrent state and eventually break down. If overcurrent continues to flow (if PO pin behaves as shown in Figure 43.), take measures to make the IC standby in terms of application.

12. Thermal Shutdown

This IC has a built-in thermal shutdown circuit as an overheat-protection measure. The thermal shutdown circuit is a circuit absolutely intended to protect the IC from thermal runaway, not intended to protect or guarantee the IC. Consequently, do not operate the thermal shutdown circuit based on the subsequent continuous use or operation of the circuit.

Power Dissipation

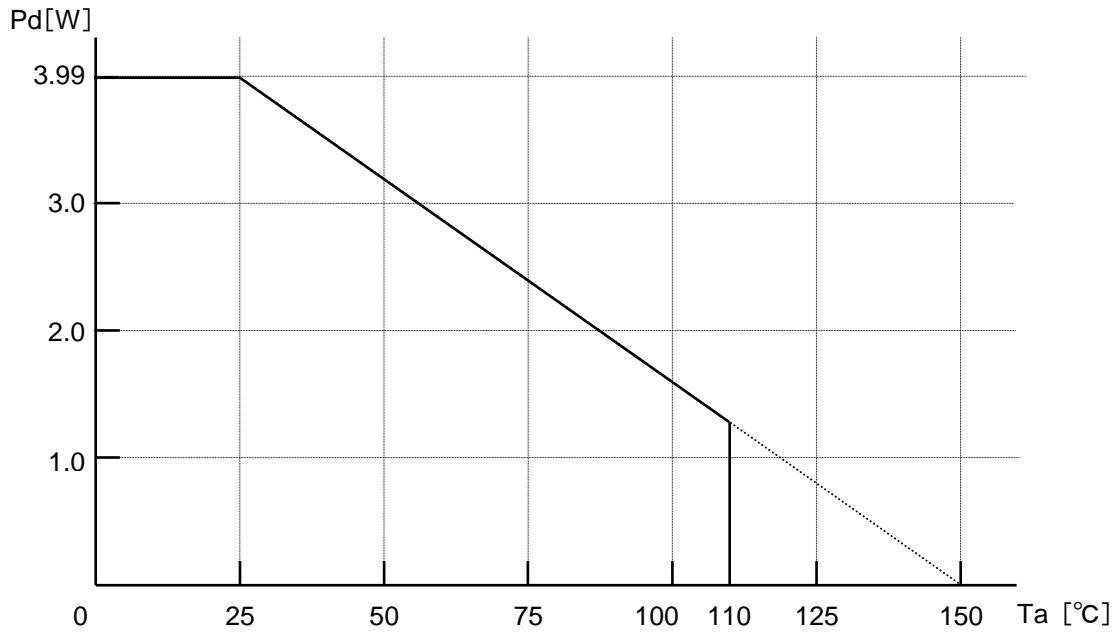

Figure 47. BD16922EFV-M Power Dissipation

Derating is done 31.9 mW/°C for operating above $T_a \geq 25^\circ\text{C}$ (Mount on 4-layer 70.0mm x 70.0mm x 1.6mm board, ROHM standard board)

I/O Equivalence Circuits^(Note 1)

Pin No.	Pin Name	I/O Equivalence Circuit
1 2 23 24	IN1P IN1N IN2N IN2P	
3 22	SGND1 SGND2	-
4 21	PO1 PO2	
5 6 19 20	PGND1 PGND1 PGND2 PGND2	-
7 8 9 10 15 16 17 18	OUT1P OUT1P OUT1N OUT1N OUT2N OUT2N OUT2P OUT2P	
11 12 13 14	PVCC1 PVCC1 PVCC2 PVCC2	-

(Note 1) Resistance values shown in the diagrams above represent a typical limit, respectively.

Operational Notes

1. Reverse Connection of Power Supply

Connecting the power supply in reverse polarity can damage the IC. Take precautions against reverse polarity when connecting the power supply, such as mounting an external diode between the power supply and the IC's power supply pins.

2. Power Supply Lines

Design the PCB layout pattern to provide low impedance supply lines. Separate the ground and supply lines of the digital and analog blocks to prevent noise in the ground and supply lines of the digital block from affecting the analog block. Furthermore, connect a capacitor to ground at all power supply pins. Consider the effect of temperature and aging on the capacitance value when using electrolytic capacitors.

3. Ground Voltage

Ensure that no pins are at a voltage below that of the ground pin at any time, even during transient condition.

4. Ground Wiring Pattern

When using both small-signal and large-current ground traces, the two ground traces should be routed separately but connected to a single ground at the reference point of the application board to avoid fluctuations in the small-signal ground caused by large currents. Also ensure that the ground traces of external components do not cause variations on the ground voltage. The ground lines must be as short and thick as possible to reduce line impedance.

5. Thermal Consideration

Should by any chance the power dissipation rating be exceeded the rise in temperature of the chip may result in deterioration of the properties of the chip. The absolute maximum rating of the Pd stated in this specification is when the IC is mounted on a 70mm x 70mm x 1.6mm glass epoxy board. In case of exceeding this absolute maximum rating, increase the board size and copper area to prevent exceeding the Pd rating.

6. Recommended Operating Conditions

These conditions represent a range within which the expected characteristics of the IC can be approximately obtained. The electrical characteristics are guaranteed under the conditions of each parameter.

7. Inrush Current

When power is first supplied to the IC, it is possible that the internal logic may be unstable and inrush current may flow instantaneously due to the internal powering sequence and delays, especially if the IC has more than one power supply. Therefore, give special consideration to power coupling capacitance, power wiring, width of ground wiring, and routing of connections.

8. Operation Under Strong Electromagnetic Field

Operating the IC in the presence of a strong electromagnetic field may cause the IC to malfunction.

9. Testing on Application Boards

When testing the IC on an application board, connecting a capacitor directly to a low-impedance output pin may subject the IC to stress. Always discharge capacitors completely after each process or step. The IC's power supply should always be turned off completely before connecting or removing it from the test setup during the inspection process. To prevent damage from static discharge, ground the IC during assembly and use similar precautions during transport and storage.

10. Inter-pin Short and Mounting Errors

Ensure that the direction and position are correct when mounting the IC on the PCB. Incorrect mounting may result in damaging the IC. Avoid nearby pins being shorted to each other especially to ground, power supply and output pin. Inter-pin shorts could be due to many reasons such as metal particles, water droplets (in very humid environment) and unintentional solder bridge deposited in between pins during assembly to name a few.

Operational Notes - continued

11. Unused Input Pins

Input pins of an IC are often connected to the gate of a MOS transistor. The gate has extremely high impedance and extremely low capacitance. If left unconnected, the electric field from the outside can easily charge it. The small charge acquired in this way is enough to produce a significant effect on the conduction through the transistor and cause unexpected operation of the IC. So unless otherwise specified, unused input pins should be connected to the power supply or ground line.

12. Regarding the Input Pin of the IC

This monolithic IC contains P+ isolation and P substrate layers between adjacent elements in order to keep them isolated. P-N junctions are formed at the intersection of the P layers with the N layers of other elements, creating a parasitic diode or transistor. For example (refer to figure below):

When $GND > Pin A$ and $GND > Pin B$, the P-N junction operates as a parasitic diode.
When $GND > Pin B$, the P-N junction operates as a parasitic transistor.

Parasitic diodes inevitably occur in the structure of the IC. The operation of parasitic diodes can result in mutual interference among circuits, operational faults, or physical damage. Therefore, conditions that cause these diodes to operate, such as applying a voltage lower than the GND voltage to an input pin (and thus to the P substrate) should be avoided.

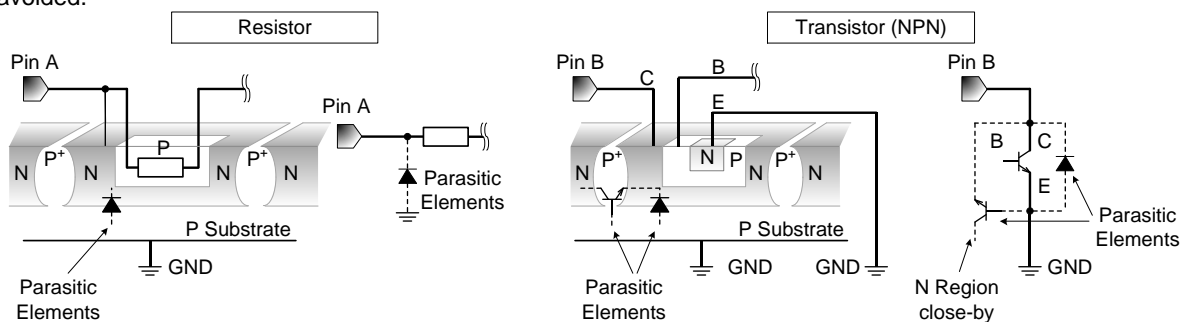

Figure 48. Example of monolithic IC structure

13. Ceramic Capacitor

When using a ceramic capacitor, determine the dielectric constant considering the change of capacitance with temperature and the decrease in nominal capacitance due to DC bias and others.

14. Area of Safe Operation (ASO)

Operate the IC such that the output voltage, output current, and power dissipation are all within the Area of Safe Operation (ASO).

15. Thermal Shutdown Circuit(TSD)

This IC has a built-in thermal shutdown circuit that prevents heat damage to the IC. Normal operation should always be within the IC's power dissipation rating. If however the rating is exceeded for a continued period, the junction temperature (T_j) will rise which will activate the TSD circuit that will turn OFF all output pins. When the T_j falls below the TSD threshold, the circuits are automatically restored to normal operation.

Note that the TSD circuit operates in a situation that exceeds the absolute maximum ratings and therefore, under no circumstances, should the TSD circuit be used in a set design or for any purpose other than protecting the IC from heat damage.

16. Over Current Protection Circuit (OCP)

This IC incorporates an integrated overcurrent protection circuit that is activated when the load is shorted. This protection circuit is effective in preventing damage due to sudden and unexpected incidents. However, the IC should not be used in applications characterized by continuous operation or transitioning of the protection circuit.

Ordering Information



Marking Diagrams

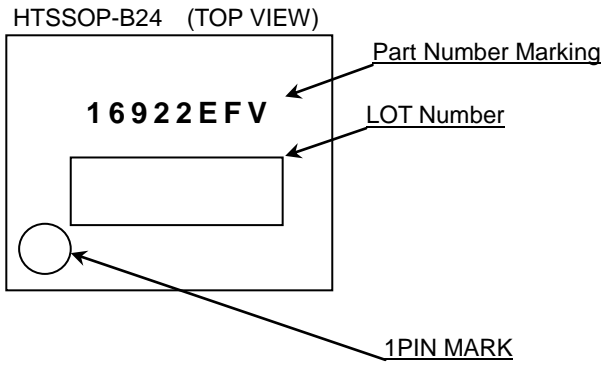

Physical Dimension, Tape and Reel Information

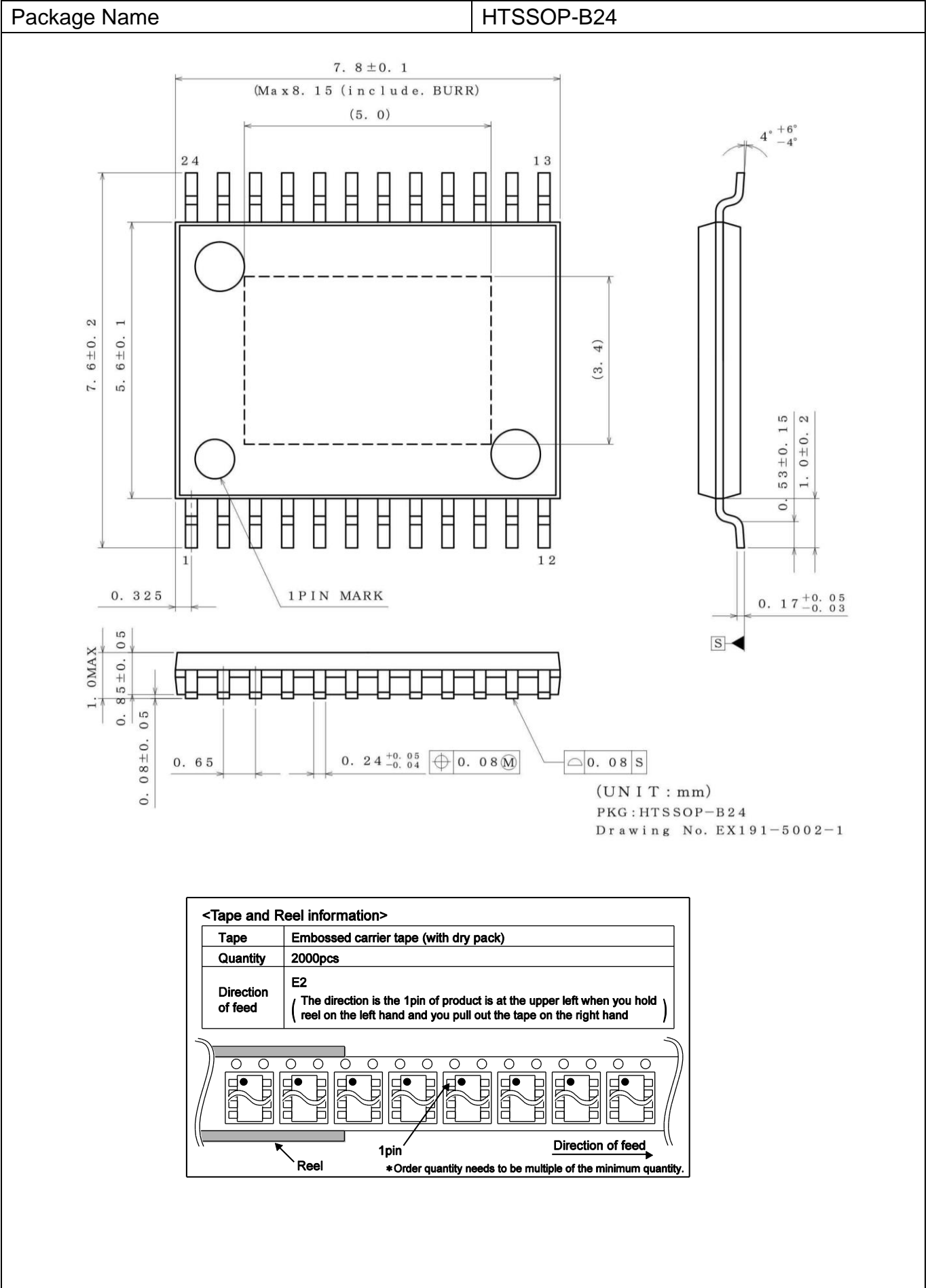

Revision History

Date	Revision	Changes
03.Oct.2013	001	New Release
29.May.2015	002	P.1 Note1 add comment Note2 add comment
11.Sep.2015	003	None (adjust revision number between Japanese version and English version)

Notice

Precaution on using ROHM Products

1. If you intend to use our Products in devices requiring extremely high reliability (such as medical equipment ^(Note 1), aircraft/spacecraft, nuclear power controllers, etc.) and whose malfunction or failure may cause loss of human life, bodily injury or serious damage to property ("Specific Applications"), please consult with the ROHM sales representative in advance. Unless otherwise agreed in writing by ROHM in advance, ROHM shall not be in any way responsible or liable for any damages, expenses or losses incurred by you or third parties arising from the use of any ROHM's Products for Specific Applications.

(Note1) Medical Equipment Classification of the Specific Applications

JAPAN	USA	EU	CHINA
CLASS III	CLASS III	CLASS II b	CLASS III
CLASS IV		CLASS III	

2. ROHM designs and manufactures its Products subject to strict quality control system. However, semiconductor products can fail or malfunction at a certain rate. Please be sure to implement, at your own responsibilities, adequate safety measures including but not limited to fail-safe design against the physical injury, damage to any property, which a failure or malfunction of our Products may cause. The following are examples of safety measures:
 - [a] Installation of protection circuits or other protective devices to improve system safety
 - [b] Installation of redundant circuits to reduce the impact of single or multiple circuit failure
3. Our Products are not designed under any special or extraordinary environments or conditions, as exemplified below. Accordingly, ROHM shall not be in any way responsible or liable for any damages, expenses or losses arising from the use of any ROHM's Products under any special or extraordinary environments or conditions. If you intend to use our Products under any special or extraordinary environments or conditions (as exemplified below), your independent verification and confirmation of product performance, reliability, etc, prior to use, must be necessary:
 - [a] Use of our Products in any types of liquid, including water, oils, chemicals, and organic solvents
 - [b] Use of our Products outdoors or in places where the Products are exposed to direct sunlight or dust
 - [c] Use of our Products in places where the Products are exposed to sea wind or corrosive gases, including Cl₂, H₂S, NH₃, SO₂, and NO₂
 - [d] Use of our Products in places where the Products are exposed to static electricity or electromagnetic waves
 - [e] Use of our Products in proximity to heat-producing components, plastic cords, or other flammable items
 - [f] Sealing or coating our Products with resin or other coating materials
 - [g] Use of our Products without cleaning residue of flux (even if you use no-clean type fluxes, cleaning residue of flux is recommended); or Washing our Products by using water or water-soluble cleaning agents for cleaning residue after soldering
 - [h] Use of the Products in places subject to dew condensation
4. The Products are not subject to radiation-proof design.
5. Please verify and confirm characteristics of the final or mounted products in using the Products.
6. In particular, if a transient load (a large amount of load applied in a short period of time, such as pulse. is applied, confirmation of performance characteristics after on-board mounting is strongly recommended. Avoid applying power exceeding normal rated power; exceeding the power rating under steady-state loading condition may negatively affect product performance and reliability.
7. De-rate Power Dissipation (Pd) depending on Ambient temperature (Ta). When used in sealed area, confirm the actual ambient temperature.
8. Confirm that operation temperature is within the specified range described in the product specification.
9. ROHM shall not be in any way responsible or liable for failure induced under deviant condition from what is defined in this document.

Precaution for Mounting / Circuit board design

1. When a highly active halogenous (chlorine, bromine, etc.) flux is used, the residue of flux may negatively affect product performance and reliability.
2. In principle, the reflow soldering method must be used on a surface-mount products, the flow soldering method must be used on a through hole mount products. If the flow soldering method is preferred on a surface-mount products, please consult with the ROHM representative in advance.

For details, please refer to ROHM Mounting specification

Precautions Regarding Application Examples and External Circuits

1. If change is made to the constant of an external circuit, please allow a sufficient margin considering variations of the characteristics of the Products and external components, including transient characteristics, as well as static characteristics.
2. You agree that application notes, reference designs, and associated data and information contained in this document are presented only as guidance for Products use. Therefore, in case you use such information, you are solely responsible for it and you must exercise your own independent verification and judgment in the use of such information contained in this document. ROHM shall not be in any way responsible or liable for any damages, expenses or losses incurred by you or third parties arising from the use of such information.

Precaution for Electrostatic

This Product is electrostatic sensitive product, which may be damaged due to electrostatic discharge. Please take proper caution in your manufacturing process and storage so that voltage exceeding the Products maximum rating will not be applied to Products. Please take special care under dry condition (e.g. Grounding of human body / equipment / solder iron, isolation from charged objects, setting of Ionizer, friction prevention and temperature / humidity control).

Precaution for Storage / Transportation

1. Product performance and soldered connections may deteriorate if the Products are stored in the places where:
 - [a] the Products are exposed to sea winds or corrosive gases, including Cl₂, H₂S, NH₃, SO₂, and NO₂
 - [b] the temperature or humidity exceeds those recommended by ROHM
 - [c] the Products are exposed to direct sunshine or condensation
 - [d] the Products are exposed to high Electrostatic
2. Even under ROHM recommended storage condition, solderability of products out of recommended storage time period may be degraded. It is strongly recommended to confirm solderability before using Products of which storage time is exceeding the recommended storage time period.
3. Store / transport cartons in the correct direction, which is indicated on a carton with a symbol. Otherwise bent leads may occur due to excessive stress applied when dropping of a carton.
4. Use Products within the specified time after opening a humidity barrier bag. Baking is required before using Products of which storage time is exceeding the recommended storage time period.

Precaution for Product Label

QR code printed on ROHM Products label is for ROHM's internal use only.

Precaution for Disposition

When disposing Products please dispose them properly using an authorized industry waste company.

Precaution for Foreign Exchange and Foreign Trade act

Since concerned goods might be fallen under listed items of export control prescribed by Foreign exchange and Foreign trade act, please consult with ROHM in case of export.

Precaution Regarding Intellectual Property Rights

1. All information and data including but not limited to application example contained in this document is for reference only. ROHM does not warrant that foregoing information or data will not infringe any intellectual property rights or any other rights of any third party regarding such information or data.
2. ROHM shall not have any obligations where the claims, actions or demands arising from the combination of the Products with other articles such as components, circuits, systems or external equipment (including software).
3. No license, expressly or implied, is granted hereby under any intellectual property rights or other rights of ROHM or any third parties with respect to the Products or the information contained in this document. Provided, however, that ROHM will not assert its intellectual property rights or other rights against you or your customers to the extent necessary to manufacture or sell products containing the Products, subject to the terms and conditions herein.

Other Precaution

1. This document may not be reprinted or reproduced, in whole or in part, without prior written consent of ROHM.
2. The Products may not be disassembled, converted, modified, reproduced or otherwise changed without prior written consent of ROHM.
3. In no event shall you use in any way whatsoever the Products and the related technical information contained in the Products or this document for any military purposes, including but not limited to, the development of mass-destruction weapons.
4. The proper names of companies or products described in this document are trademarks or registered trademarks of ROHM, its affiliated companies or third parties.

General Precaution

1. Before you use our Products, you are requested to carefully read this document and fully understand its contents. ROHM shall not be in any way responsible or liable for failure, malfunction or accident arising from the use of any ROHM's Products against warning, caution or note contained in this document.
2. All information contained in this document is current as of the issuing date and subject to change without any prior notice. Before purchasing or using ROHM's Products, please confirm the latest information with a ROHM sales representative.
3. The information contained in this document is provided on an "as is" basis and ROHM does not warrant that all information contained in this document is accurate and/or error-free. ROHM shall not be in any way responsible or liable for any damages, expenses or losses incurred by you or third parties resulting from inaccuracy or errors of or concerning such information.



BD16922EFV-M - Web Page

Part Number	BD16922EFV-M
Package	HTSSOP-B24
Unit Quantity	2000
Minimum Package Quantity	2000
Packing Type	Taping
Constitution Materials List	inquiry
RoHS	Yes