

Pin 1 marking

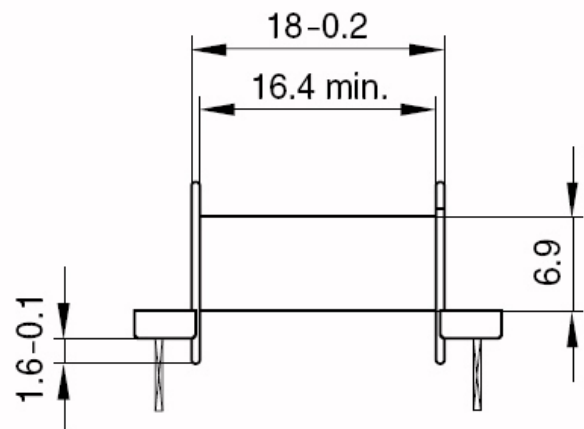
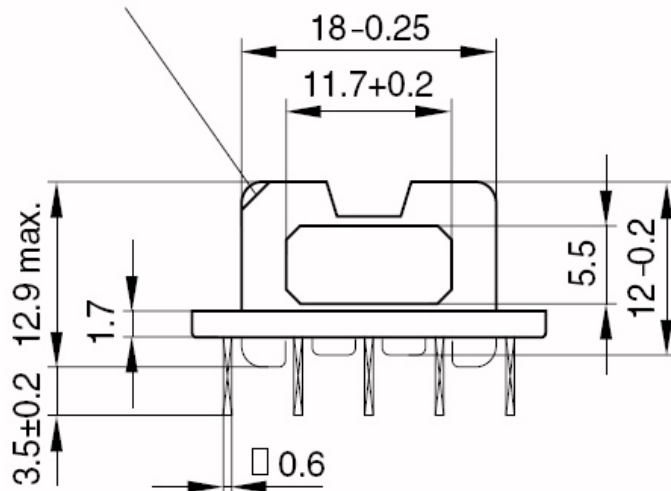

Material: GFR thermosetting plastic (UL 94 V-0, insulation class to IEC 60085:

H max. operating temperature 180°C), color code black

Sumikon PM 9630 @ [E41429 (M)], SUMITOMO BAKELITE CO LTD

Solderability: to IEC 60068-2-20, test Ta, method 1 (aging 3): 235°C , 2 s

Resistance to soldering heat: to IEC 60068-2-20, test Tb, method 1B: 350°C , 3.5 s