

Photoflash Flyback Transformer

EPC3205G-X & EPC3205G-X-LF

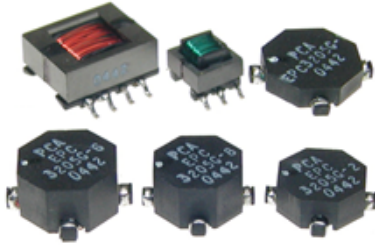

- Used as Flyback Transformer in High Voltage Photoflash Capacitor Charger
- Designed for use with Linear Technology Chip
- Add “-LF” after part number for Lead Free
- Operating Temperature : -40°C to +85°C
- UL 94V-0 Recognized Components
- UL 1446 Class B Insulation System
- Isolation : 500 Vrms

Electrical Parameters @ 25° C

PCA Part Number	Chipset	Voltage (Vdc)		Primary Peak Current (A Max.)	Turns Ratio Pri:Sec	Primary OCL @ 0A _{dc} (µH ± 15%) @ 100 KHz, 0.1 Vrms	Leakage Inductance (µH Typ.) @ 100 KHz, 0.1 Vrms	DCR (Max.)		Package/Schematic
		V in	V out					Pri.	Sec.	
EPC3205G-1A(-LF)	LT3468	2.5-5.0	320	1.4	1:10.2	20.0	0.200	0.300	25	B/1
EPC3205G-2(-LF)	LT3468	2.5-5.0	320	1.4	1:10.2	12.3	0.130	0.230	21	A/1
	LT3468-2	2.5-5.0	320	1.0	1:10.2	12.3	0.130	0.230	21	A/1
EPC3205G-3(-LF)	LT3468	2.5-4.0	320	1.4	1:10.2	10.0	0.200	0.250	25	E/2
EPC3205G-4(-LF)	LT3468-2	2.5-5.0	320	1.0	1:10.2	10.0	0.300	0.300	37	E/2
EPC3205G-5(-LF)	LT3468-1	2.5-5.0	320	0.7	1:10.2	15.0	0.300	0.300	37	E/2
EPC3205G-6(-LF)	LT3420	1.8-5.0	320	1.4	1:12	25.0	0.130	0.160	18	B/1
EPC3205G-7(-LF)	LT3420	1.8-6.0	320	1.4	1:12	24.0	0.080	0.160	18	D/3
EPC3205G-8(-LF)	LT3420-1	1.8-5.0	320	1.0	1:10.2	15.0	0.100	0.230	18	C/1

Schematic 1

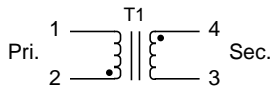

Schematic 2

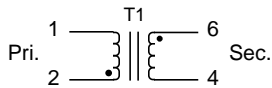

Schematic 3

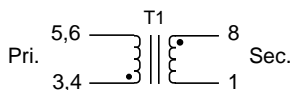

LT3420 320V Photoflash Capacitor Charging Circuit

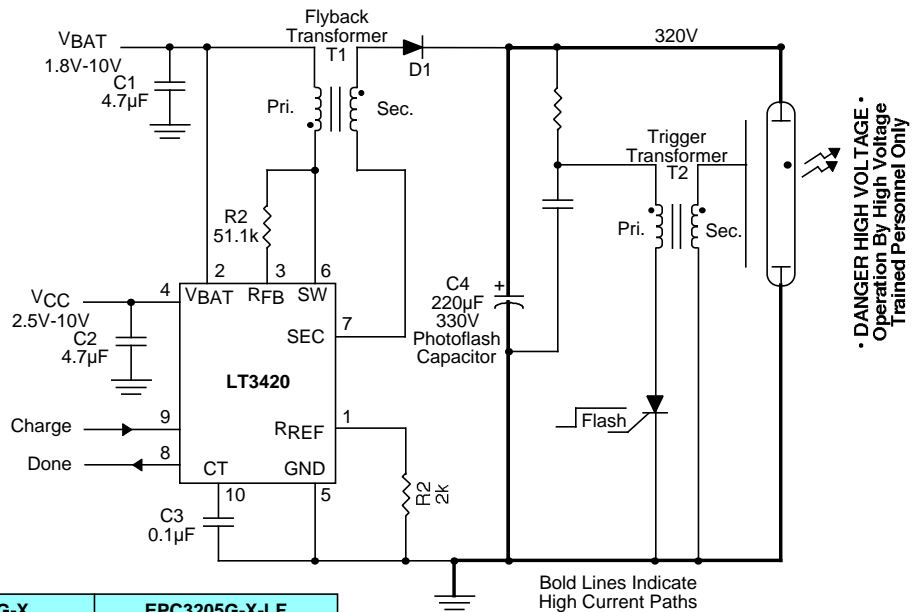

Notes :	EPC3205G-X	EPC3205G-X-LF
1. Assembly Process (Solder Composition)	SnPb	Pb-Free
2. Peak Solder Rating (per IPC/JEDEC-J-STD-020C)	225°C	260°C
3. Moisture Sensitive Levels (MSL) (per IPC/JEDEC-J-STD-020C)	1 (Unlimited, 30°C/60%RH)	1 (Unlimited, 30°C/60%RH)
4. Weight	TBD grams	TBD grams
5. Packaging Information (Tube)	TBD pcs / tube	TBD pcs / tube

Package Drawings Next Page

Unless Otherwise Specified Dimensions are in Inches /mm ± .010 / .25

Photoflash Flyback Transformer

EPC3205G-X & EPC3205G-X-LF

Package A

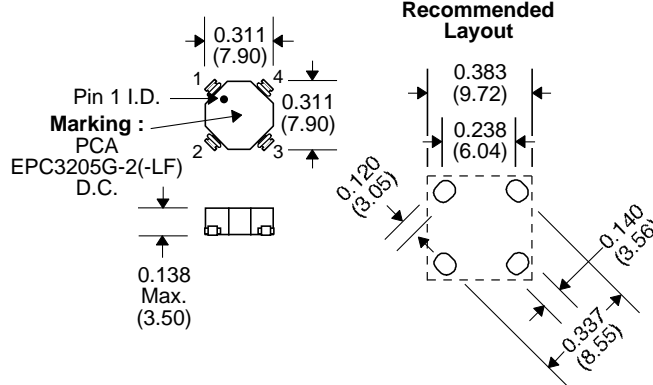

Package B

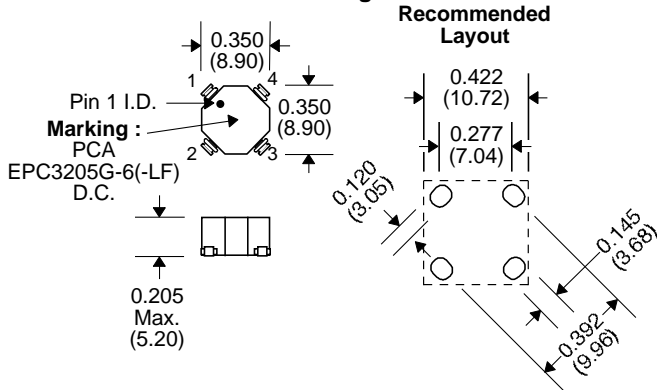

Package C

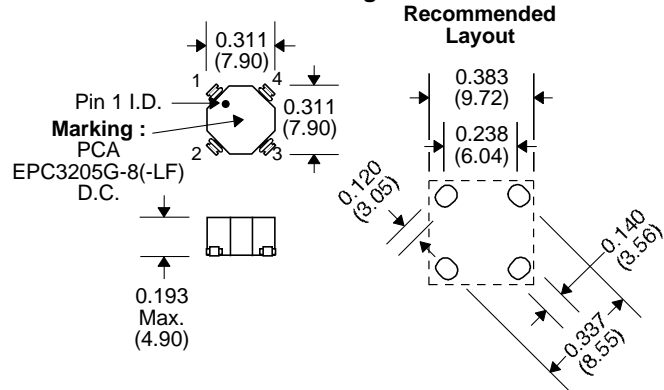

Package D

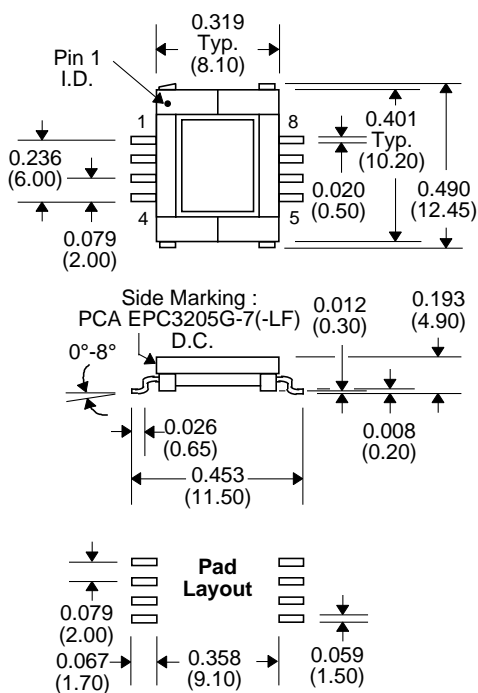

Package E

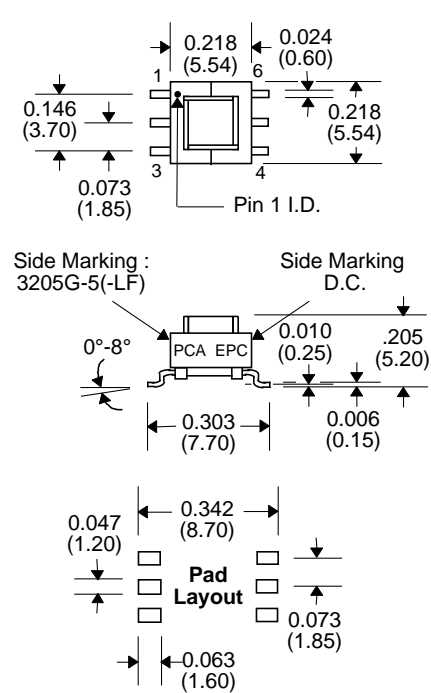

Unless Otherwise Specified Dimensions are in Inches /mm ± .010 / .25