



# DATASHEET



## VHR30-2800D SERIES HIGH RELIABILITY COTS DC-DC CONVERTERS

### Models Available

Input: 15 V to 50 V continuous, 80 V transient  
30 W, dual outputs of 5 V, 12 V, 15 V  
-40 °C to 100 °C Operation

### 1.0 DESCRIPTION

The VHR series of industrial grade DC-DC converters provides cost effective, high reliability solutions for use in defense, avionics and manufacturing industries. The VHR industrial grade products leverage decades of VPT's proven heritage in military and aerospace electronics.

VPT's VHR30-2800D series is ideal for non flight-critical solutions in military, avionics, unmanned systems as well as manufacturing equipment and controls. A wide input voltage range which accommodates nominal 28 V inputs, low input and output ripple, fixed operating frequency and companion EMI filters simplify system design while ensuring operating success in the most rugged of environments.

These converters are designed and manufactured in a facility certified to ISO9001, J-STD-001 and IPC-A-610.

This product may incorporate one or more of the following U.S. patents:

- 5,784,266
- 5,790,389
- 5,963,438
- 5,999,433
- 6,005,780
- 6,084,792
- 6,118,673



### 1.1 FEATURES

- High Reliability at Low Cost
- 30 Watts Output Power
- Wide Input Voltage Range: 15 to 50 Volts per MIL-STD-704 and MIL-STD-1275
- High Input Transient Voltage: 80 Volts for 1 sec per MIL-STD-704A
- Input Undervoltage Lockout
- Fixed Frequency
- Frequency Synchronization
- Output Soft Start
- Current Limit Protection
- Short Circuit Protection
- Magnetic Feedback, no Optoisolators
- Wide Temperature Range, -40 °C to 100 °C
- Internally Conformal Coated
- Standard Six Sided Non-Hermetic Rugged Metal Package

### 1.2 COMPLIANCE

- MIL-STD-1275
- MIL-STD-704
- Meets MIL-STD-461C-F and EN55022 when used with an appropriate VHR EMI Filter

### 1.3 PACKAGING

- Low-profile: 1.885" x 1.325" x 0.400"
- Max weight: 48 g

### 1.4 SIMILAR PRODUCTS AND ACCESSORIES

- [DVTR](#) 40 W dual output DC-DC Converter
- [VPT30](#) 30 W dual output COTS DC-DC Converter
- [EMI filters, Thermal Pads, Front-End Modules and Accessories](#)

2.0 DESCRIPTION

2.1 BLOCK DIAGRAM

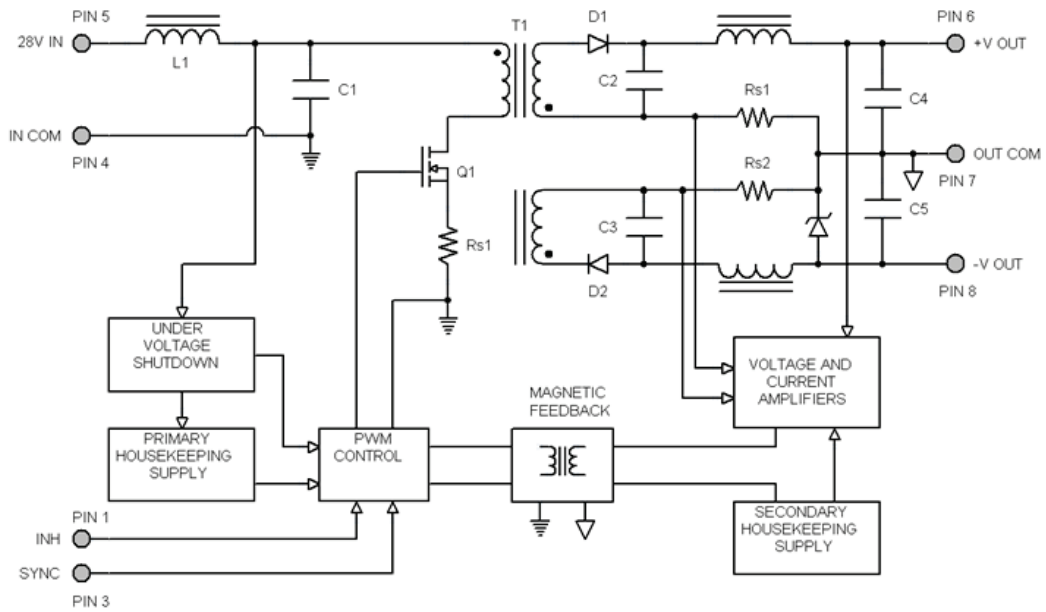

2.2 CONNECTION DIAGRAM

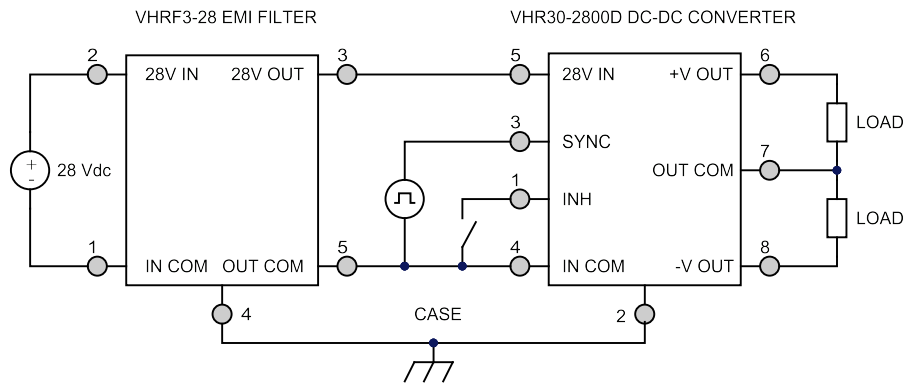

2.2 CONNECTION DIAGRAM (CONTINUED)

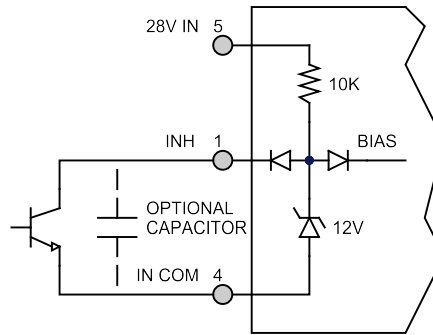

Inhibit Circuit (Shown with optional capacitor for turn-on delay)

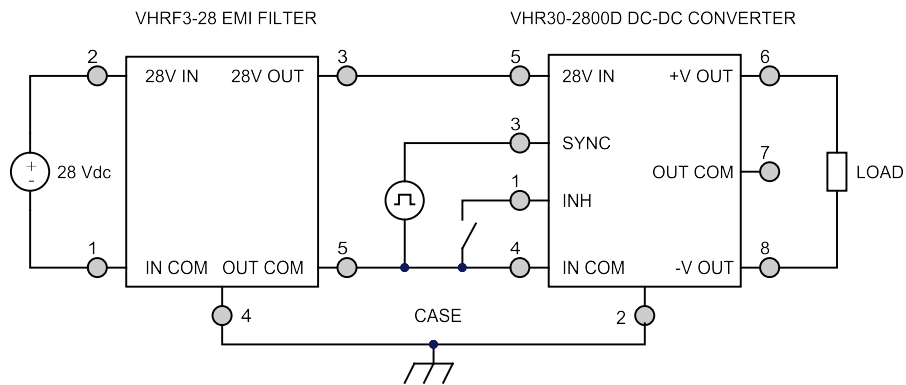

Stacked Output Connection (Shown with optional EMI filter)

### 3.0 SPECIFICATIONS

#### 3.1 ABSOLUTE MAXIMUM RATINGS

##### Absolute Maximum Ratings

Input Voltage (Continuous):	50 V	Operating Temperature (Full Load):	-40 °C to 100 °C
Input Voltage (Transient, 1 second):	80 V	Storage Temperature:	-55 °C to 125 °C
		Lead Solder Temperature (10 seconds):	300 °C

#### 3.2 PERFORMANCE SPECIFICATIONS

Tcase = -40 °C to 100 °C, Vin = +28 V ± 5%, Full Load<sup>4</sup>, Unless Otherwise Specified

Parameter	Conditions	VHR30-2805D			VHR30-2812D			Units
		Min	Typ	Max	Min	Typ	Max	
<b>INPUT</b>								
Voltage	Continuous	15	28	50	15	28	50	V
	Transient, 1 sec <sup>3</sup>	-	-	80	-	-	80	V
Current	INH < 1.5 V	-	4	6	-	4	6	mA
	No Load	-	50	90	-	50	90	mA
Ripple Current	20 Hz to 10 MHz	-	30	75	-	30	75	mApp
Undervoltage Lockout	Turn On	12	-	14.8	12	-	14.8	V
	Turn Off <sup>3</sup>	11	-	14.5	11	-	14.5	V
<b>OUTPUT STATIC</b>								
Voltage	+Vout, T <sub>CASE</sub> = 25 °C	4.92	5	5.08	11.82	12	12.18	V
	+Vout, T <sub>CASE</sub> = -40 °C to 100 °C	4.87	5	5.13	11.7	12	12.3	V
	-Vout, T <sub>CASE</sub> = 25 °C	4.87	5	5.13	11.7	12	12.3	V
	-Vout, T <sub>CASE</sub> = -40 °C to 100 °C	4.82	5	5.18	11.58	12	12.42	V
Power <sup>2,5</sup>	Total	0	-	30	0	-	30	W
	Either Output	0	-	21	0	-	21	W
Current <sup>2,5</sup>	Either Output	0	-	4.2	0	-	1.75	A
Ripple Voltage	20 Hz to 10 MHz	-	15	50	-	25	50	mVpp
Line Regulation	+Vout, V <sub>IN</sub> = 15 V to 50 V	-	1	10	-	1	10	mV
	-Vout, V <sub>IN</sub> = 15 V to 50 V	-	80	150	-	80	150	mV
Load Regulation <sup>6</sup>	+Vout, No Load to Full Load	-	1	10	-	1	10	mV
	-Vout, No Load to Full Load	-	30	100	-	30	150	mV
Cross Regulation, -Vout	+Vout: 70% load, -Vout: 30% load +Vout: 30% load, -Vout: 70% load	-	200	400	-	300	500	mV
Load Fault Power Dissipation	Overload <sup>3</sup>	-	-	16	-	-	14	W
	Short Circuit	-	-	16	-	-	14	W
<b>OUTPUT DYNAMIC</b>								
Load Step, Half to Full Load	Output Transient	-	100	300	-	250	450	mVpk
	Recovery <sup>1</sup>	-	40	200	-	200	400	µs
Line Step <sup>3</sup> , Vin = 16 V to 40 V	Output Transient	-	300	600	-	700	1100	mVpk
	Recovery <sup>1</sup>	-	150	400	-	300	500	µs
Turn On, Vin = 0 to 28 V	Delay	-	10	20	-	10	20	ms
	Overshoot	-	0	25	-	0	50	mVpk
<b>FUNCTION</b>								
INH Pin Input <sup>3</sup>	Output Inhibited	0	-	1.5	0	-	1.5	V
INH Pin Open Circuit Voltage <sup>3</sup>	Output Enabled	9	11	13	9	11	13	V
SYNC Frequency Range	V <sub>H</sub> - V <sub>L</sub> = 5 V, D = 50%	500	-	600	500	-	600	kHz
<b>GENERAL</b>								
Efficiency		74	81	-	79	84	-	%
Capacitive Load <sup>3</sup>	Either Output	-	-	500	-	-	500	µF
Switching Frequency		400	450	550	400	450	550	kHz
Isolation	500 V DC, Tcase = 25 °C	100	-	-	100	-	-	MΩ
Weight		-	-	48	-	-	48	g
MTBF (MIL-HDBK-217F)	GM @ Tcase = 55 °C	-	371	-	-	371	-	kHr

1. Time for output voltage to settle within 1% of its nominal value
2. Derate linearly to 0 at 110 °C
3. Verified by qualification testing
4. Half Load at +VOUT and half load at -VOUT
5. Up to 70% of the total power or current can be drawn from any one of the two outputs
6. 5% Load to Full Load at -40 °C

### 3.2 PERFORMANCE SPECIFICATIONS (CONTINUED)

Tcase = -40 °C to 100 °C, Vin = +28 V ± 5%, Full Load<sup>4</sup>, Unless Otherwise Specified

VHR30-2815D					
Parameter	Conditions	Min	Typ	Max	Units
<b>INPUT</b>					
Voltage	Continuous	15	28	50	V
	Transient, 1 sec <sup>3</sup>	-	-	80	V
Current	INH < 1.5 V	-	4	6	mA
	No Load	-	50	90	mA
Ripple Current	20 Hz to 10 MHz	-	30	75	mApp
Undervoltage Lockout	Turn On	12	-	14.8	V
	Turn Off <sup>3</sup>	11	-	14.5	V
<b>OUTPUT STATIC</b>					
Voltage	+Vout, Tcase = 25 °C	14.77	15	15.23	V
	+Vout, Tcase = -40 °C to 100 °C	14.62	15	15.38	V
	- Vout, Tcase = 25 °C	14.62	15	15.38	V
	- Vout, Tcase = -40 °C to 100 °C	14.47	15	15.53	V
Power <sup>2,5</sup>	Total	0	-	30	W
	Either Output	0	-	21	W
Current <sup>2,5</sup>	Either Output	0	-	1.4	A
Ripple Voltage	20 Hz to 10 MHz	-	25	50	mVpp
Line Regulation	+Vout, Vin = 15 V to 50 V	-	1	10	mV
	- Vout, Vin = 15 V to 50 V	-	80	150	mV
Load Regulation <sup>6</sup>	+Vout, No Load to Full Load	-	1	10	mV
	- Vout, No Load to Full Load	-	30	150	mV
Cross Regulation, -Vout	+Vout: 70% load, -Vout: 30% load	-	300	500	mV
	+Vout: 30% load, -Vout: 70% load	-	-	-	-
Load Fault Power Dissipation	Overload <sup>3</sup>	-	-	14	W
	Short Circuit	-	-	14	W
<b>OUTPUT DYNAMIC</b>					
Load Step, Half to Full Load	Output Transient	-	250	450	mVpk
	Recovery <sup>1</sup>	-	200	400	µs
Line Step <sup>3</sup> , Vin = 16 V to 40 V	Output Transient	-	700	1100	mVpk
	Recovery <sup>1</sup>	-	300	500	µs
Turn On, Vin = 0 to 28 V	Delay	-	10	20	ms
	Overshoot	-	0	50	mVpk
<b>FUNCTION</b>					
INH Pin Input <sup>3</sup>	Output Inhibited	0	-	1.5	V
INH Pin Open Circuit Voltage <sup>3</sup>	Output Enabled	9	11	13	V
SYNC Frequency Range	V <sub>H</sub> - V <sub>L</sub> = 5 V, D = 50%	500	-	600	kHz
<b>GENERAL</b>					
Efficiency		79	84	-	%
Capacitive Load <sup>3</sup>	Either Output	-	-	500	µF
Switching Frequency		400	450	550	kHz
Isolation	500 V DC, Tcase = 25 °C	100	-	-	MΩ
Weight		-	-	48	g
MTBF (MIL-HDBK-217F)	GM @ Tcase = 55 °C	-	371	-	kHr

1. Time for output voltage to settle within 1% of its nominal value
2. Derate linearly to 0 at 110 °C
3. Verified by qualification testing
4. Half Load at +VOUT and half load at -VOUT
5. Up to 70% of the total power or current can be drawn from any one of the two outputs
6. 5% Load to Full Load at -40 °C



#### 4.0 PERFORMANCE CURVES

T<sub>case</sub> = 25 °C, Full Load, Unless Otherwise Specified

#### 4.1 EFFICIENCY PERFORMANCE CURVES

4.1.1 VHR30-2805D Efficiency (%) vs. Output Power (W)

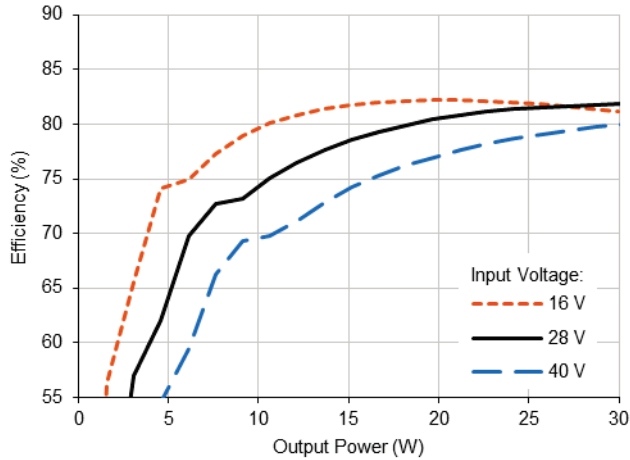

4.1.2 VHR30-2812D Efficiency (%) vs. Output Power (W)

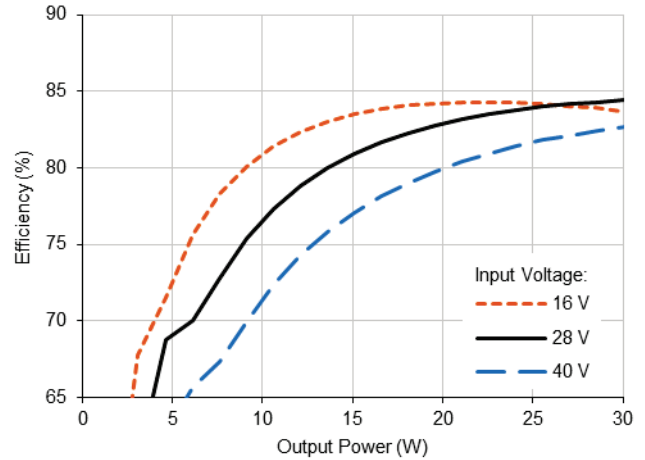

4.1.3 VHR30-2815D Efficiency (%) vs. Output Power (W)

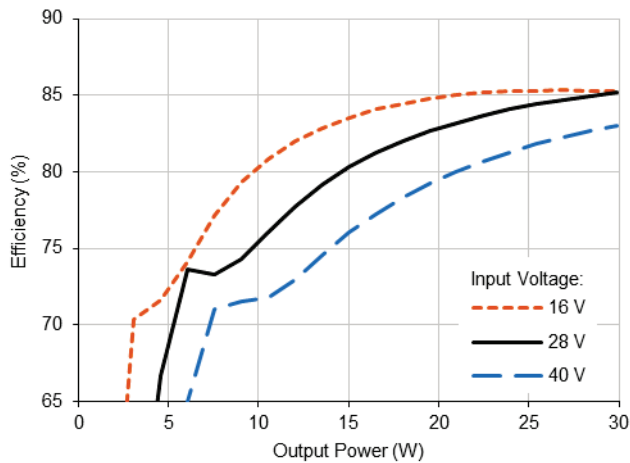

4.0 PERFORMANCE CURVES (CONTINUED)

4.2 CROSS REGULATION CURVES

4.2.1 VHR30-2805D -Vout (V) vs. -Iout (A)

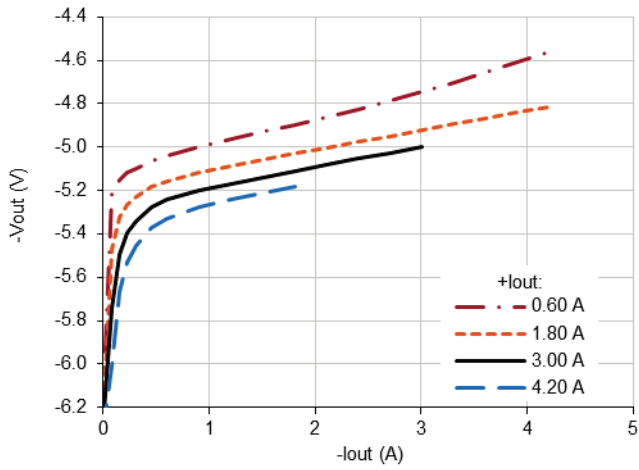

4.2.2 VHR30-2812D -Vout (V) vs. -Iout (A)

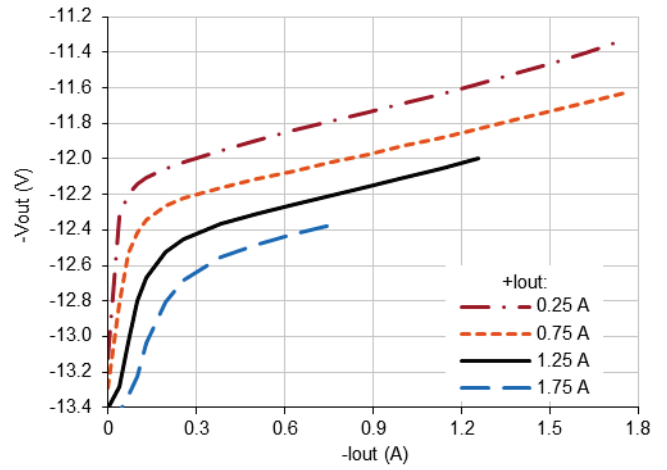

4.2.3 VHR30-2815D -Vout (V) vs. -Iout (A)

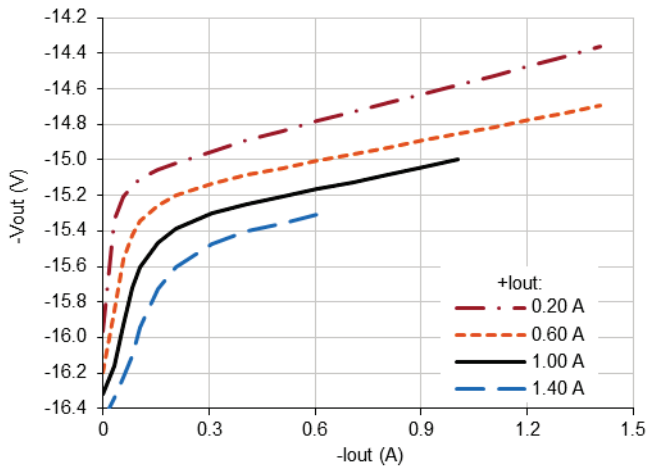

5.0 MECHANICAL OUTLINES AND PINOUT

Standard Metal Package:

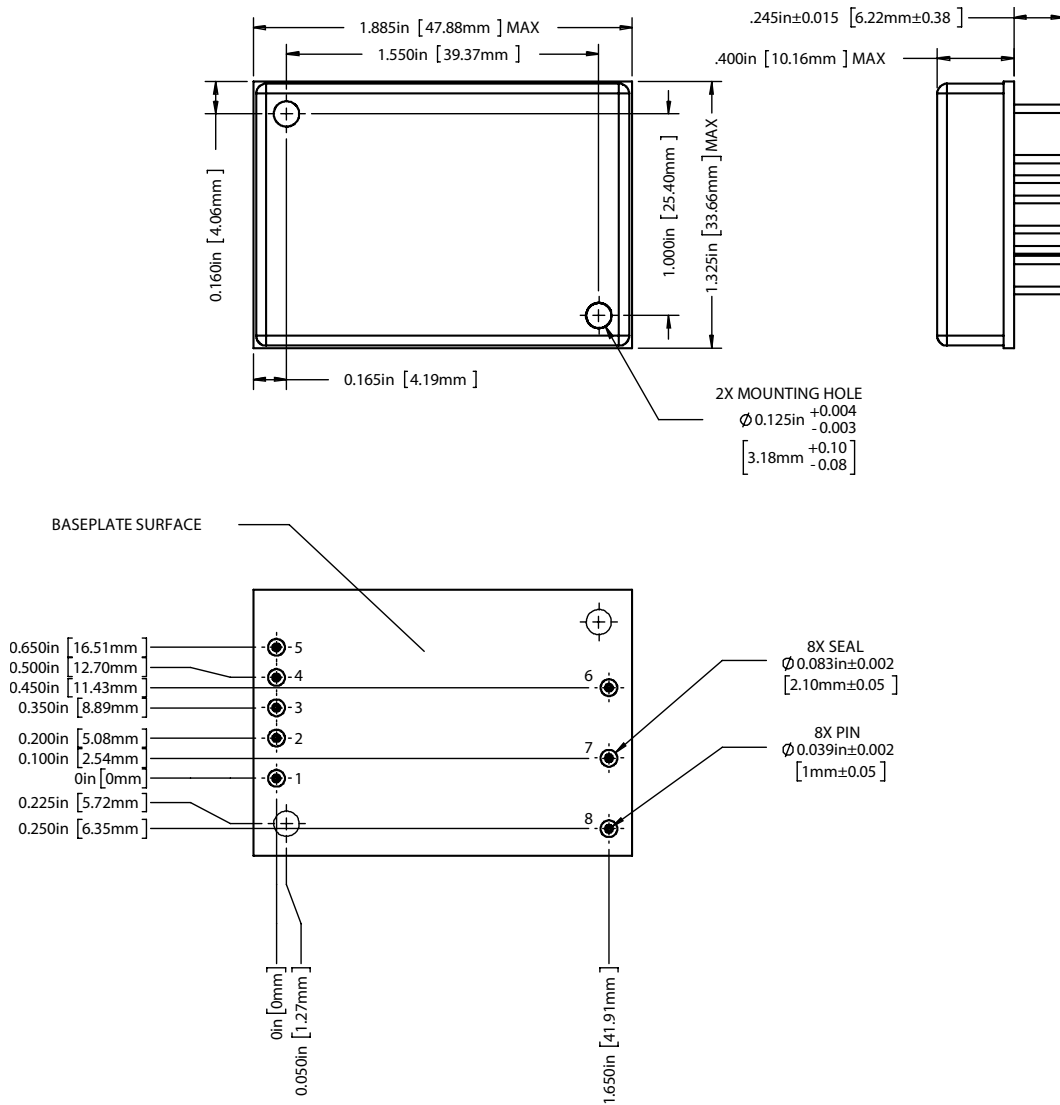

1. Case temperature is measured on the center of the baseplate surface.
2. Materials: Baseplate (Aluminum, conductive conversion coating); Cover (Nickel Plated); Pins (Copper, gold over nickel plating)
3. Mounting holes are not threaded. Recommended fastener is 4-40
4. This Package is not hermetic. VPT offers a wide range of hermetic products. Please contact VPT for details if hermetic products are required.

Pin	Function	Pin	Function
1	INHIBIT	5	28VIN
2	CASE	6	+VOUT
3	SYNC	7	OUTCOM
4	INCOM	8	-VOUT





### 6.0 PACKAGE PIN DESCRIPTION

Pin	Function	Description
1	INHIBIT	This is an open collector input. Logic Low = Disabled Output. Connect the inhibit pin to input common to disable the output. Unconnected, open collector or open drain = Enabled Output.
2	CASE	Case Connection.
3	SYNC	Frequency Synchronization Signal Input. TTL squarewave, 5 Vpp, 20 – 80% duty cycle, internally capacitively coupled.
4	INCOM	Input Return Connection.
5	28VIN	Positive Input Voltage Connection.
6	+VOUT	Positive Output Voltage Connection.
7	OUTCOM	Output Return Connection.
8	-VOUT	Negative Output Voltage Connection.

### 7.0 ENVIRONMENTAL SCREENING

Screening	Condition
Internal Visual	IPC-A-610, Class 3
Final Electrical	100% at 25 °C
External Visual	Internal Procedure

### 8.0 ORDERING INFORMATION

VHR30-	28	05	D
1	2	3	4

(1) Product Series	(2) Nominal Input Voltage	(3) Output Voltage	(4) Number of Outputs
VHR30-	28	28 Volts	D
		05 ±5 Volts	Dual
		12 ±12 Volts	
		15 ±15 Volts	

Please contact your sales representative or the VPT Inc. Sales Department for more information concerning additional environmental screening and testing, different input voltage, output voltage, power requirements, and source inspection.

**9.0 CONTACT INFORMATION**

To request a quotation or place orders please contact your sales representative or the VPT, Inc. Sales Department at:

**Phone:** (425) 353-3010  
**Fax:** (425) 353-4030  
**E-mail:** vptsales@vptpower.com

All information contained in this datasheet is believed to be accurate, however, no responsibility is assumed for possible errors or omissions. The products or specifications contained herein are subject to change without notice. VPT, its logo and tagline are registered trademarks in the U.S. Patent and Trademark Office.

**10.0 ADDITIONAL INFORMATION**

Visit the [VPT website](http://www.vptpower.com) for additional technical resources, including:

[Product Literature](#)



[Application Notes and White Papers](#)

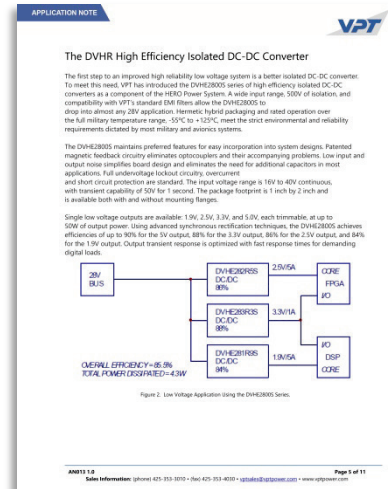

[Technical Video Labs](#)



**Additional Products For [Avionics/Military](#), [Hi-Temp](#), [Hi-Rel COTS](#), and [Space Applications](#)**

