

FAN8042

5-CH Motor Driver

FAN8042 Features

- 4-CH balanced transformerless (BTL) driver
- 1-CH (forward reverse) control DC motor driver
- Operating supply voltage (4.5 V ~ 13.2 V)
- Built in thermal shut down circuit (TSD)
- Built in channel mute circuit
- Built in power save mode circuit
- Built in TSD monitor circuit
- Built in 2-OP AMPs

Description

The FAN8042 is a monolithic integrated circuit suitable for a 5-CH motor driver which drives the tracking actuator, focus actuator, sled motor, spindle motor, and tray motor of the CDP/CAR-CD/DVDP systems.

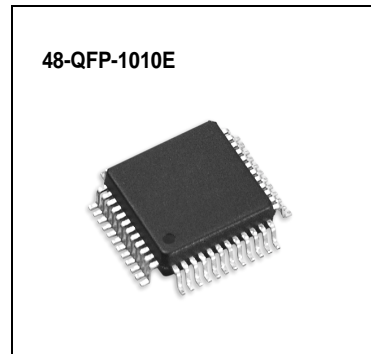

Typical Application

- Compact disk player
- Video compact disk player
- Car compact disk player
- Digital video disk player

Ordering Information

Device	Package	Operating Temperature
FAN8042	48-QFP-1010E	-35°C ~ +85°C

Pin Assignments

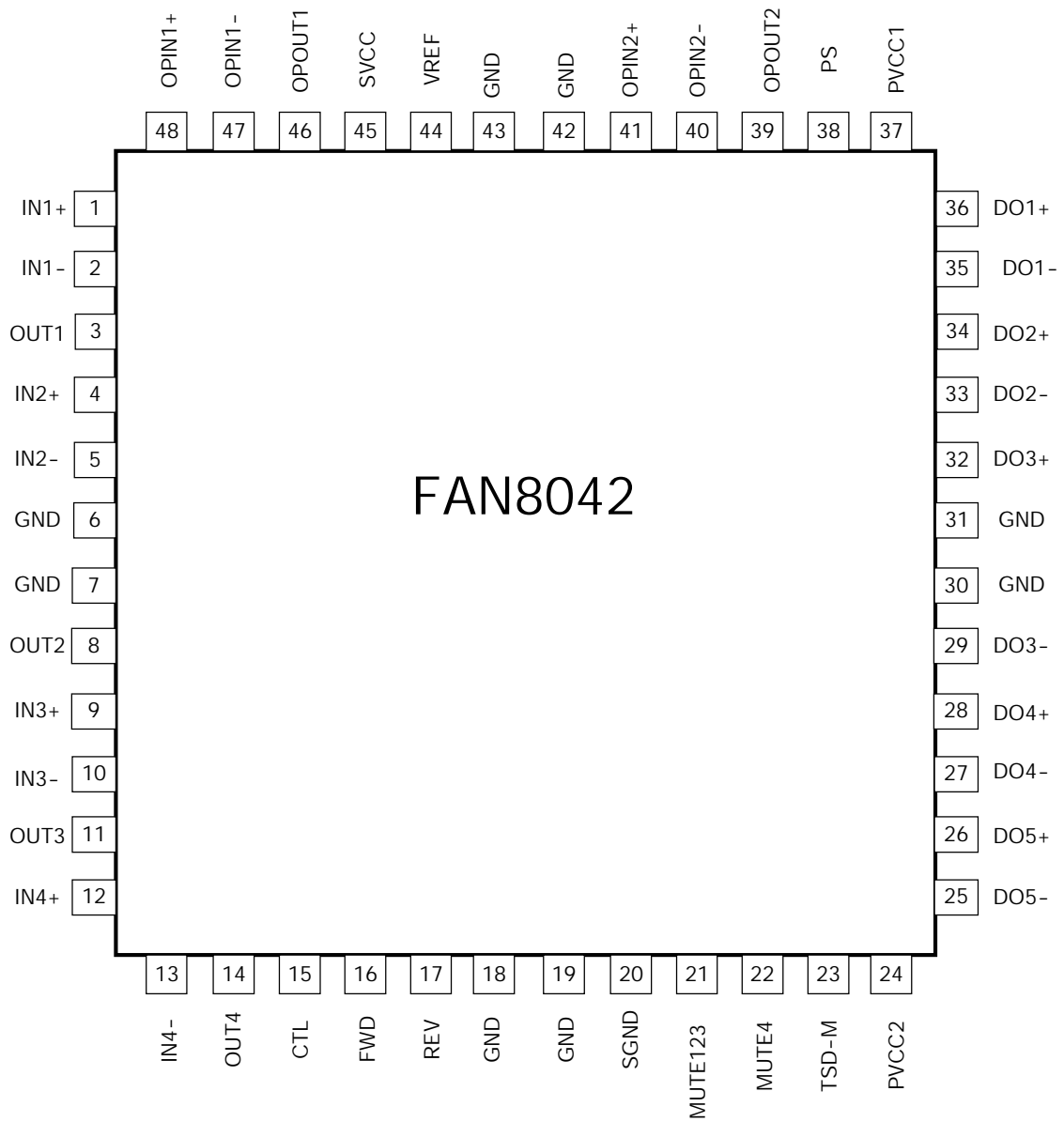

Pin Definitions

Pin Number	Pin Name	I/O	Pin Function Description
1	IN1+	I	CH1 op-amp input (+)
2	IN1-	I	CH1 op-amp input (-)
3	OUT1	O	CH1 op-amp output
4	IN2+	I	CH2 op-amp input (+)
5	IN2-	I	CH2 op-amp input (-)
6	GND	-	Ground
7	GND	-	Ground
8	OUT2	O	CH2 op-amp output
9	IN3+	I	CH3 op-amp input (+)
10	IN3-	I	CH3 op-amp input (-)
11	OUT3	O	CH3 op-amp output
12	IN4+	I	CH4 op-amp input (+)
13	IN4-	I	CH4 op-amp input (-)
14	OUT4	O	CH4 op-amp output
15	CTL	I	CH5 motor speed control
16	FWD	I	CH5 forward input
17	REV	I	CH5 reverse input
18	GND	-	Ground
19	GND	-	Ground
20	SGND	-	Signal Ground
21	MUTE123	I	Mute for CH1,2,3
22	MUTE4	I	Mute for CH4
23	TSD-M	O	TSD monitor
24	PVCC2	-	Power supply voltage 2 (For CH4, CH5)
25	DO5-	O	CH5 drive output (-)
26	DO5+	O	CH5 drive output (+)
27	DO4-	O	CH4 drive output (-)
28	DO4+	O	CH4 drive output (+)
29	DO3-	O	CH3 drive output (-)
30	GND	-	Ground
31	GND	-	Ground
32	DO3+	O	CH3 drive output (+)

Pin Definitions (Continued)

Pin Number	Pin Name	I/O	Pin Function Description
33	DO2-	O	CH2 drive output (-)
34	DO2+	O	CH2 drive output (+)
35	DO1-	O	CH1 drive output (-)
36	DO1+	O	CH1 drive output (+)
37	PVCC1	-	Power supply voltage 1 (FOR CH1, CH2, CH3)
38	PS	I	Power save
39	OPOUT2	O	Normal op-amp2 output
40	OPIN2-	I	Normal op-amp2 input (-)
41	OPIN2+	I	Normal op-amp2 input (+)
42	GND	-	Ground
43	GND	-	Ground
44	VREF	I	Bias voltage input
45	SVCC	-	Signal & OPAMPs supply voltage
46	OPOUT1	O	Normal op-amp1 output
47	OPIN1-	I	Normal op-amp1 input (-)
48	OPIN1+	I	Normal op-amp1 input (+)

Internal Block Diagram

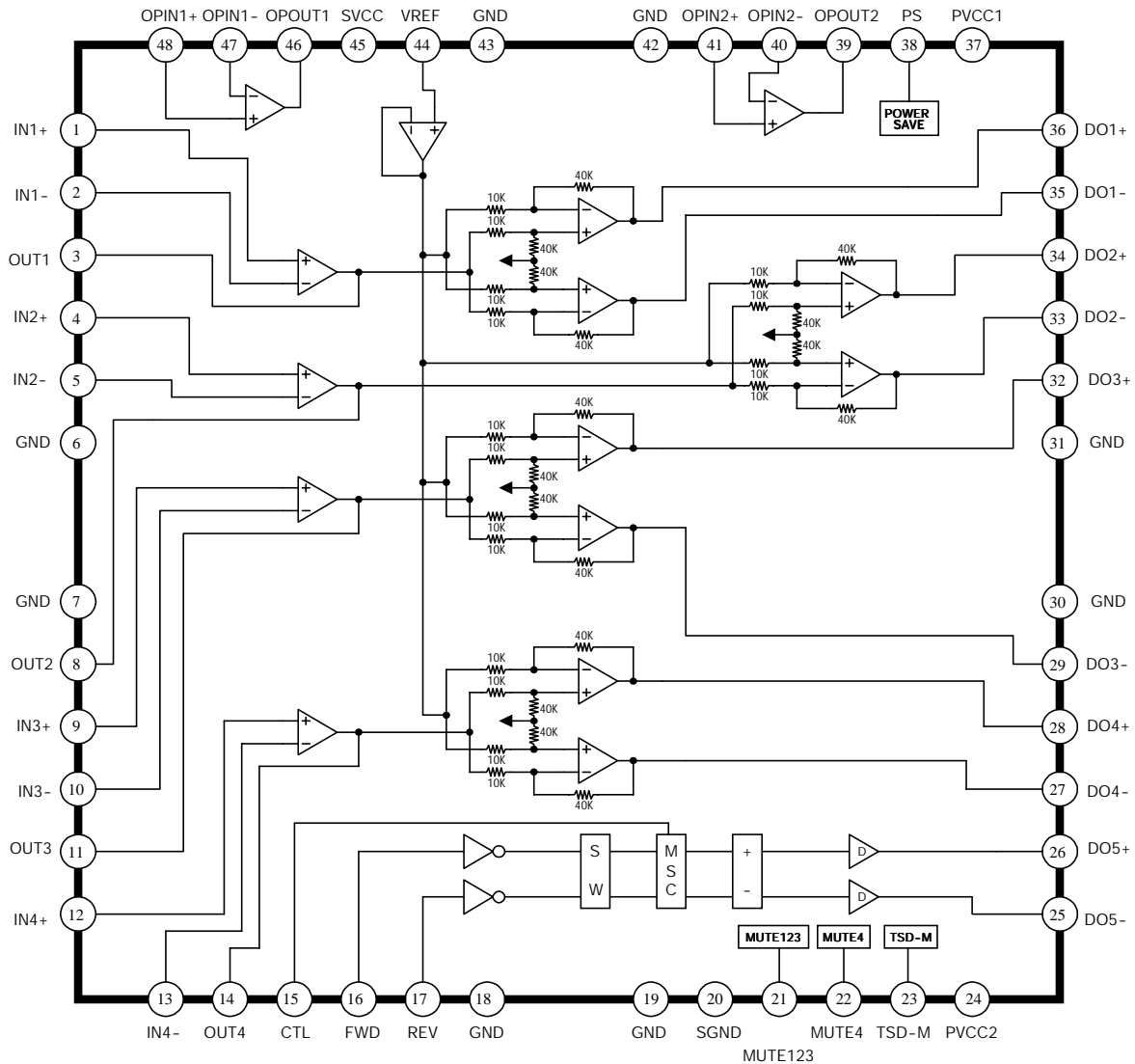

Note. Detailed circuit of the output power amp

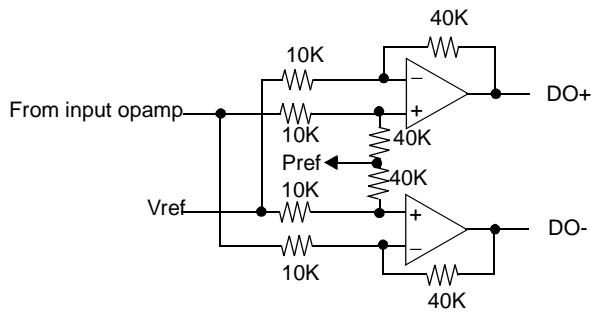

Pref1 is almost $PVCC1 / 2$
 Pref2 is almost $PVCC2 / 2$

Equivalent Circuits

Description	Pin No	Internal Circuit
BTL INPUT	1,4,9,12, 2,5,10,13	
OP AMP INPUT	40,41	
VREF	44	
OP AMP OUTPUT	3,8,11,14	

Equivalent Circuits

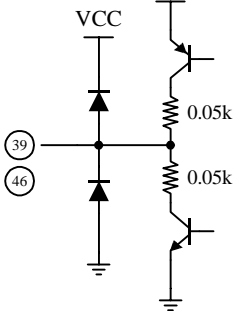
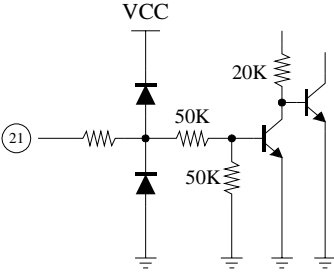
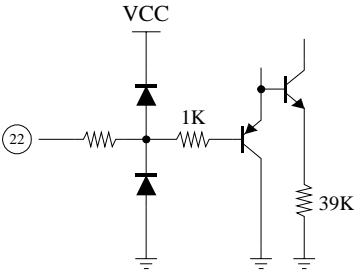
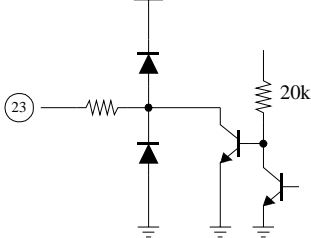
Description	Pin No	Internal Circuit
OP OUT	39,46	
MUTE123	21	
MUTE4	22	
TSD-M	23	

Equivalent Circuits

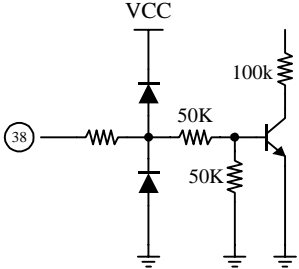
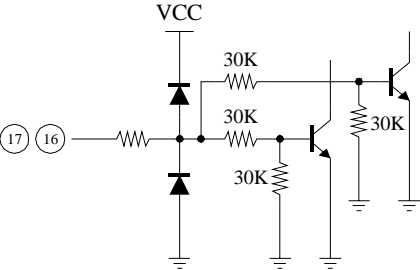
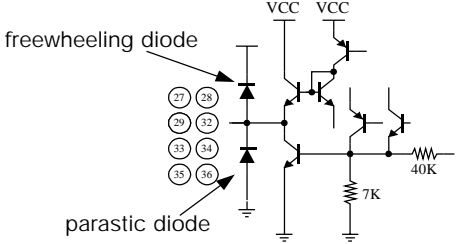
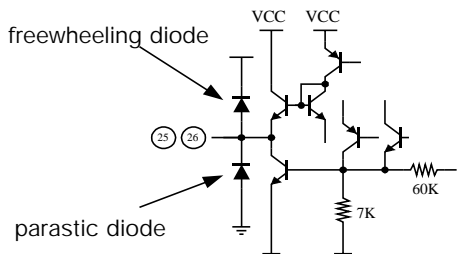
Description	Pin No	Internal Circuit
PS	38	
FWD,REV	16,17	
OUTPUT	27,29,33,35, 28,32,34,36	
OUTPUT	25,26	

Absolute Maximum Ratings (Ta=25°C)

Parameter	Symbol	Value	Unit
Maximum Supply Voltage	SVCCMAX	18	V
	PVCC1	18	V
	PVCC2	18	V
Power Dissipation	PD	2.3 ^{note}	W
Operating Temperature	TOPR	-35 ~ +85	°C
Storage Temperature	TSTG	-55 ~ +150	°C
Maximum Output Current	IOMAX	1	A

Notes:

1. When mounted on 70mm × 70mm × 1.6mm PCB
2. Power dissipation reduces 24mW/°C for using above TA = 25°C
3. Do not exceed PD and SOA

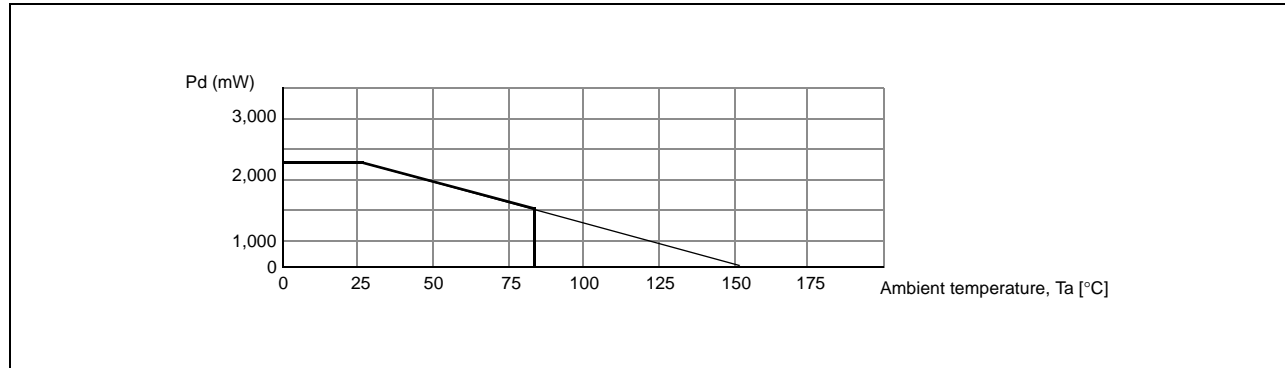

Recommended Operating Conditions (Ta=25°C)

Parameter	Symbol	Min.	Typ.	Max.	Unit
Operating Supply Voltage	SVCC	4.5	-	13.2	V
	PVCC1	4.5	-	13.2	V
	PVCC2	4.5	-	13.2	V

Electrical Characteristics

(SVCC = 5V, PVCC1 = PVCC2 = 11V, TA = 25°C, unless otherwise specified)

Parameter	Symbol	Conditions	Min.	Typ.	Max.	Unit
Quiescent circuit current	ICC	Under no-load	-	30	-	mA
Power save on current	IPS	Under no-load (Note1)	-	-	1	mA
Power save on voltage	VPSON	Pin38 = Variation	-	-	0.5	V
Power save off voltage	VPSOFF	Pin38 = Variation	2	-	-	V
Mute123 on voltage	VMON123	Pin21 = Variation	-	-	0.5	V
Mute123 off voltage	VMOFF123	Pin21 = Variation	2	-	-	V
Mute4 on voltage	VMON4	Pin22 = Variation	-	-	0.5	V
Mute4 off voltage	VMOFF4	Pin22 = Variation	2	-	-	V
BTL DRIVER CIRCUIT						
Output offset voltage	VOO	VIN = 2.5V	-100	-	+100	mV
Maximum output voltage 1	VOM1	RL = 10Ω	7.5	9.0	-	V
Maximum output voltage 2	VOM2	RL = 18Ω	8.5	9.5	-	V
Closed-loop voltage gain	AVF	VIN = 0.1Vrms	16.8	18	19.2	dB
Ripple rejection ratio	RR	VIN = 0.1Vrms, f = 120Hz	-	60	-	dB
Slew rate	SR	Square, Vout = 4Vp-p	1	2	-	V/μs
INPUT OPAMP CIRCUIT						
Input offset voltage 1	VOF1	-	-10	-	+10	mV
Input bias current 1	IB1	-	-	-	400	nA
High level output voltage 1	VOH1	-	4.4	4.7	-	V
Low level output voltage 1	VOL1	-	-	0.2	0.5	V
Output sink current 1	ISINK1	RL = 50Ω	1	2	-	mA
Output source current 1	ISOU1	RL = 50Ω	1	2	-	mA
Common mode input range1	VICM1	-	-0.3	-	4.0	V
Open loop voltage gain 1	GVO1	VIN = -75dB	-	80	-	dB
Ripple rejection ratio 1	RR1	VIN = -20dB, f = 120Hz	-	65	-	dB
Common mode rejection ratio 1	CMRR1	VIN = -20dB	-	80	-	dB
Slew rate 1	SR1	Square, Vout = 3Vp-p	-	1.5	-	V/μs

Note:

1. When the voltage of the pin38 is below 0.5V then the power save circuit cuts off the main bias current, so that the whole circuits are disabled (whole circuits are "drive circuit ", "input op amp circuit " and "nomal op amp circuit ")

Electrical Characteristics (Continued)

(SVCC = 5V, PVCC1 = PVCC2 = 11V, TA = 25°C, unless otherwise specified)

Parameter	Symbol	Conditions	Min.	Typ.	Max.	Unit
NORMAL OP AMP CIRCUIT 1						
Input offset voltage 2	VOF2	-	-10	-	+10	mV
Input bias current 2	IB2	-	-	-	400	nA
High level output voltage 2	VOH2	-	4.4	4.7	-	V
Low level output voltage 2	VOL2	-	-	0.2	0.5	V
Output sink current 2	ISINK2	RL = 50Ω	2	4	-	mA
Output source current 2	ISOU2	RL = 50Ω	2	4	-	mA
Common mode input range 2	Vicm2	-	-0.3	-	4.0	V
Open loop voltage gain 2	GVO2	VIN = -75dB	-	80	-	dB
Ripple rejection ratio 2	RR2	VIN = -20dB, f = 120Hz	-	65	-	dB
Common mode rejection ratio 2	CMRR2	VIN = -20dB	-	80	-	dB
Slew rate 2	SR2	Square, Vout = 3Vp-p	-	1.5	-	V/μs
NORMAL OP AMP CIRCUIT 2						
Input offset voltage 3	VOF3	-	-15	-	+15	mV
Input bias current 3	IB3	-	-	-	400	nA
High level output voltage 3	VOH3	-	3	3.8	-	V
Low level output voltage 3	VOL3	-	-	1.0	1.5	V
Output sink current 3	ISINK3	RL = 50Ω	10	-	-	mA
Output source current 3	ISOU3	RL = 50Ω	10	-	-	mA
Open loop voltage gain 3	GVO3	VIN = -75dB	-	80	-	dB
Ripple rejection ratio 3	RR3	VIN = -20dB, f = 120Hz	-	65	-	dB
Common mode rejection ratio 3	CMRR3	VIN = -20dB	-	80	-	dB
Slew rate 3	SR3	Square, Vout = 3Vp-p	-	1.5	-	V/μs
TRAY DRIVE CIRCUIT						
Input high level voltage	VIH	-	2	-	-	V
Input low level voltage	VIL	-	-	-	0.5	V
Output voltage 1	VO1	PVCC2 = 11V, VCTL = 3V, RL = 45Ω	-	6	-	V
Output voltage 2	VO2	PVCC2 = 13V, VCTL = 4.5V, RL = 45Ω	-	9	-	V
Output voltage 3	VO3	PVCC2 = 11V, VCTL = 1.5V, RL = 10Ω	2.5	3	3.5	V
Output load regulation	ΔVRL	VCTL = 3V, IL = 100mA → 400mA	-	300	700	mV
Output offset voltage 1	VOO1	VIN = 5V, 5V	-40	-	+40	mV
Output offset voltage 2	VOO2	VIN = 0V, 0V	-40	-	+40	mV

Application Information

1. Thermal Shutdown

- When the chip temperature reaches to 160°C by abnormal condition, then the TSD circuit is activated.
- This shut down the bias current of the output drivers, and all the output drivers are in cut-off state. Thus the chip temperature begin to decrease.
- when the chip temperature falls to 135°C, the TSD circuit is deactivated and the output drivers are normally operated.
- The TSD circuit has the hysteresis temperature of 25°C.

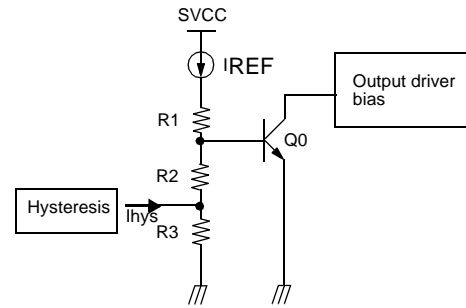

2. CH MUTE Function

- When the pin21,22 is high, the TR Q1 is turned on and Q2 is off, so the bias circuit is enabled. On the other hand, when the pin21,22 is Low (GND), the TR Q1 is turned off and Q2 is on, so the bias circuit is disabled.
- That is, this function will cause all the output drivers to be in mute state.
- Truth table is as follows;

Pin 21,22	FAN8042
High	Mute-Off
Low	Mute-On

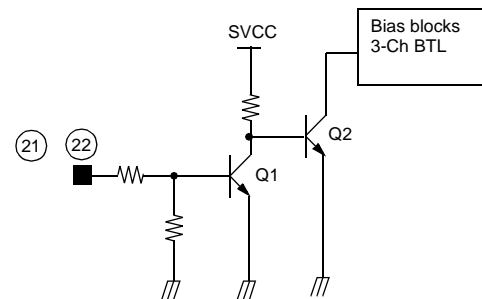

3. Power Save Function

- When the pin38 is high, the TR Q3 is turned on and Q4 is off, so the bias circuit is enabled. On the other hand, when the pin38 is Low (GND), the TR Q3 is turned off and Q4 is on, so the bias circuit is disabled.
- That is, this function keeps all the circuit blocks of the chip off, thus the low power quiescent state is established
- Truth table is as follows;

Pin38	FAN8042
High	Power Save Off
Low	Power Save On

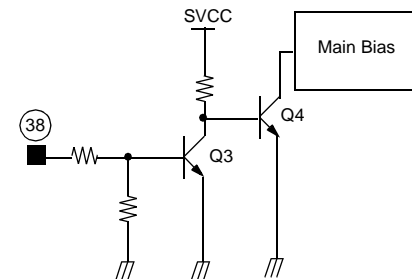

4. Tsd Monitor Function

- PIN23 is TSD monitor pin which detects the state of the TSD block and generates the TSD-monitor signal.
- In normal state Q5 is turned on, so Q6 is turned off. on the otherhand, When the TSD block is activated then Q5 is turned off, so the voltage of pin23 is low.
- Truth table is as follows

pin23	FAN8042
High	Tsd Off
Low	Tsd On

5. Focus, Tracking Actuator, Spindle, Sled Motor Drive Part

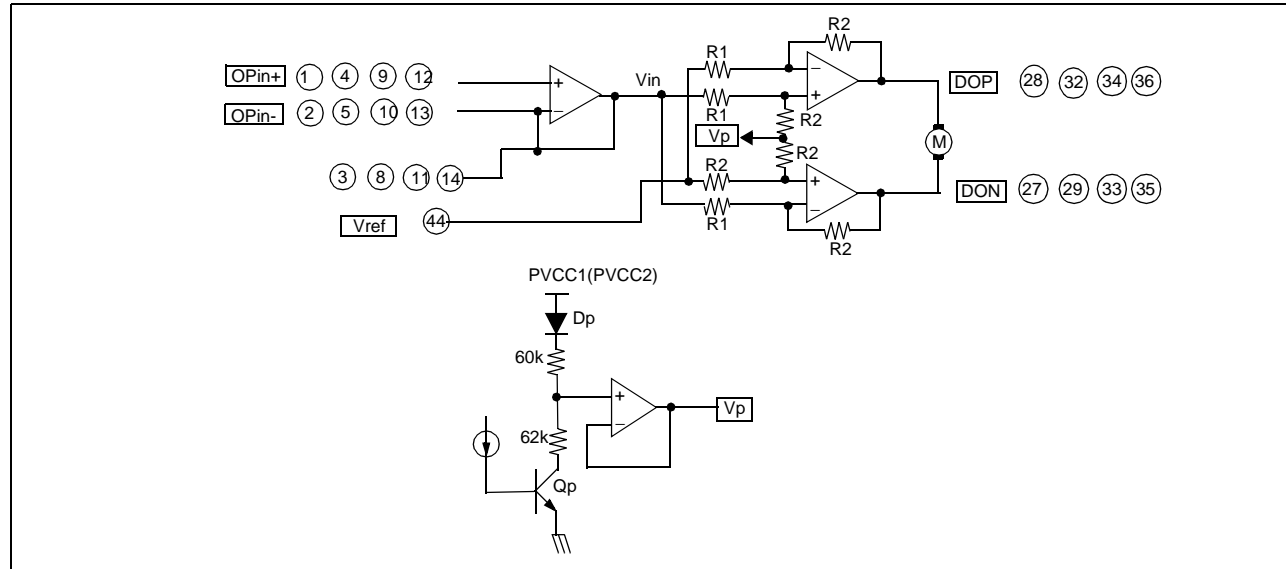

- The voltage, Vref is the reference voltage given by the external bias voltage of the pin 44.
- The input signal (Vin) through pins 1,4,9, 12 is amplified one time and then fed to the output stage. (assume that input opamp was used as a buffer)
- The total closed loop voltage gain is as follows

$$V_{in} = V_{ref} + \Delta V$$

$$DOP = V_p + 4\Delta V$$

$$DON = V_p - 4\Delta V$$

$$V_{out} = DOP - DON = 8\Delta V$$

$$Gain = 20 \log \frac{V_{out}}{\Delta V} = 20 \log 8 = 18 \text{ dB}$$

- If you want to change the total closed loop voltage gain, you must use the input opamp as an amplifier
- The output stage is the balanced transformerless (BTL) driver.
- The bias voltage Vp is expressed as ;

$$V_p = (PVCC1 - VD_p - V_{cesatQp}) \times \frac{62k}{60k + 62k} + V_{cesatQp}$$

$$= \frac{PVCC1 - VD_p + V_{cesatQp}}{1.97} + V_{cesatQp} \quad \text{----- (1)}$$

6. Tray, Changer,panel Motor Drive Part

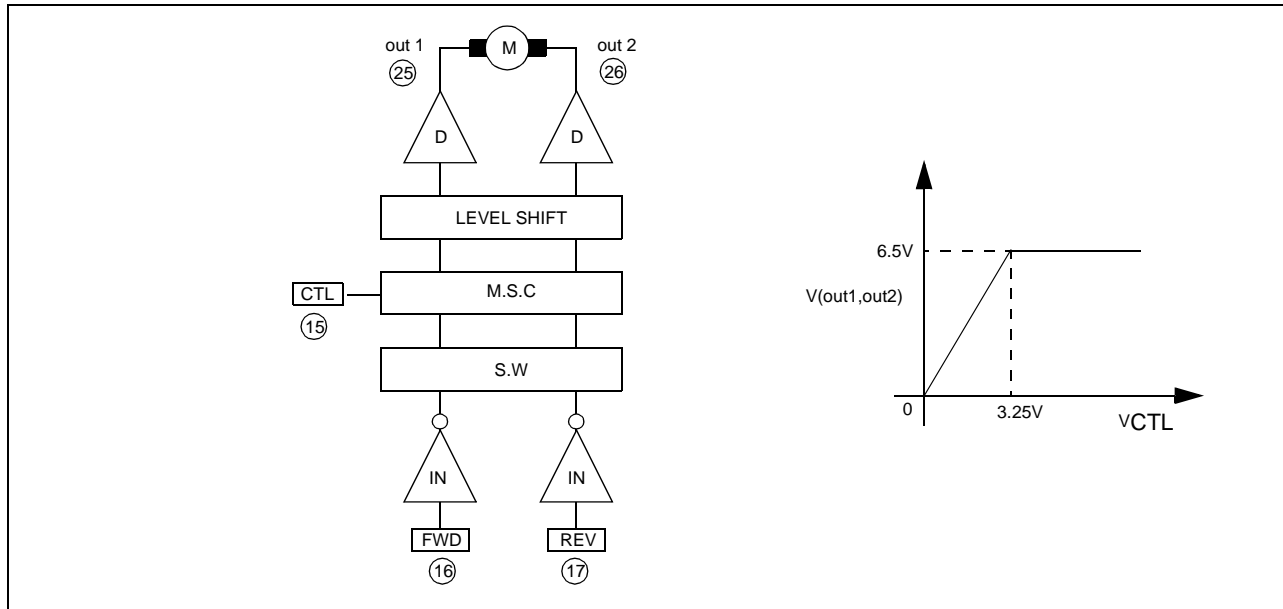

- Rotational direction control

The forward and reverse rotational direction is controlled by FWD (pin16) and REV (pin17) and the input conditions are as follows.

INPUT		OUTPUT		
FWD	REV	OUT 1	OUT 2	State
H	H	Vp	Vp	Brake
H	L	H	L	Forward
L	H	L	H	Reverse
L	L	-	-	High impedance

- Where Vp(Power reference voltage) is approximately about 3.75V at PVCC2=8V according to equation (1).
- Motor speed control (When SVCC=PVCC2=8V)
 - The almost maximum torque is obtained when the VCTL is open.
 - If the voltage of the pin15 is 0V, the motor will not operate.
 - When the control voltage of the pin15 is between 0 and 3.25V, the differential output voltage(V(out1,out2)) is about two times of control voltage. Hence, the control to the differential output gain is two.
 - When the control voltage is greater than 3.25V, the output voltage is saturated at the 6.5V because of the output swing limitation.

Test Circuits

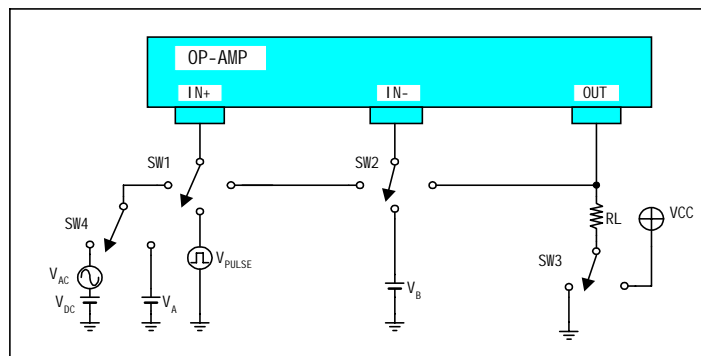
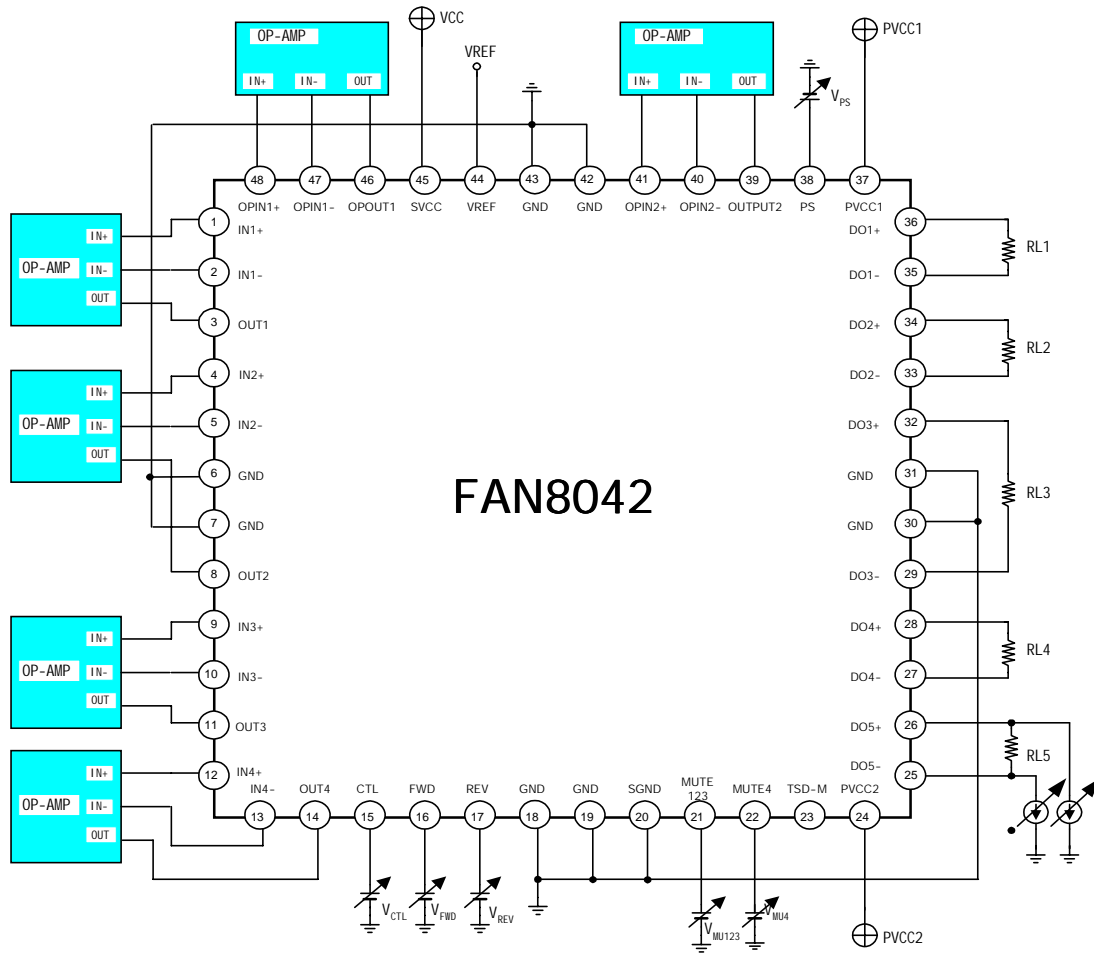

Typical Application Circuits 1

[Voltage mode control mode]

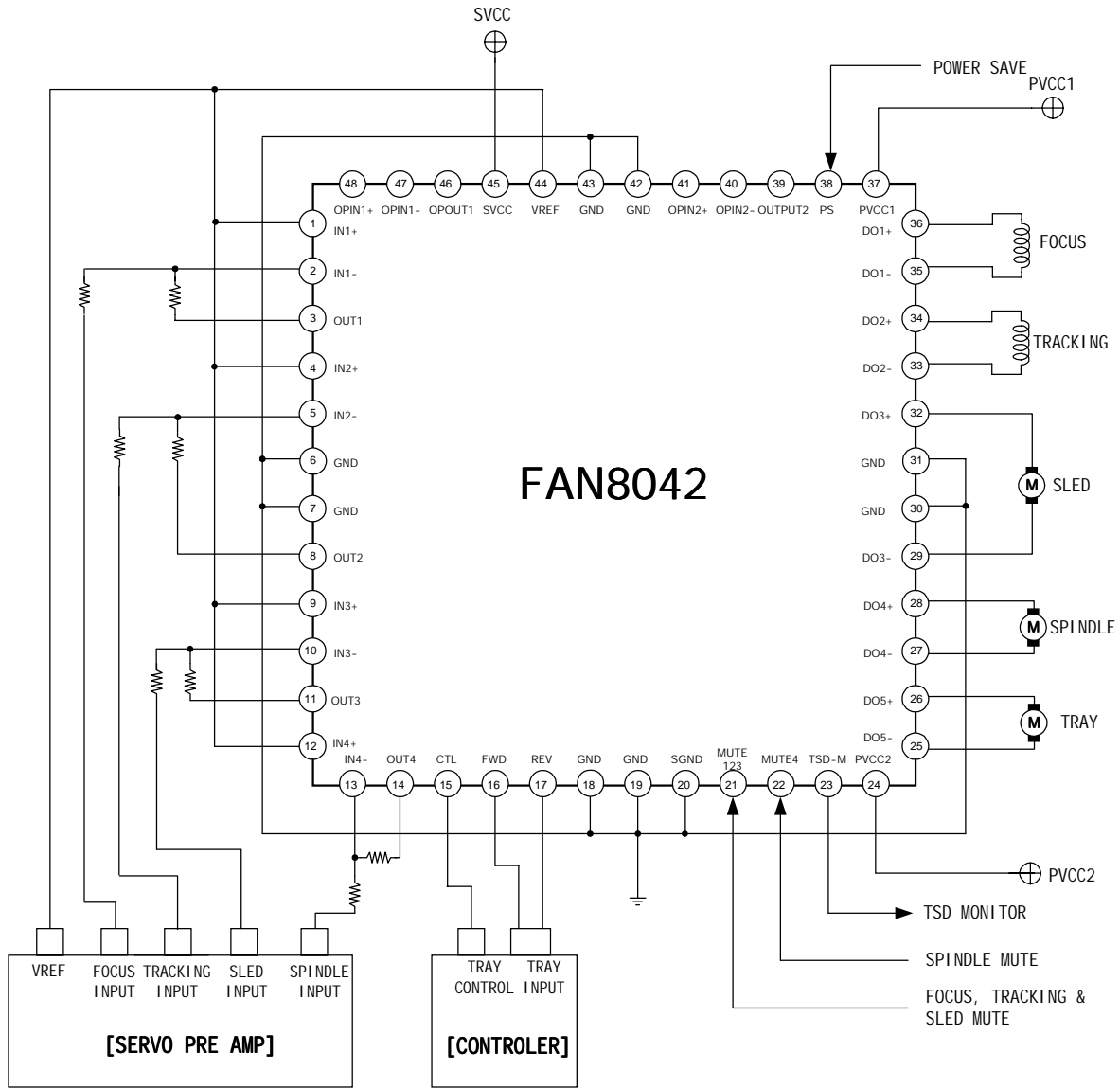

Notes:

- Radiation pin is connected to the internal GND of the package.
- Connect the pin to the external GND
- This device that named FAN8042 is the same as FAN8034, and this datasheet was made for particular customers

Typical Application Circuits 2

[Differential PWM control mode]

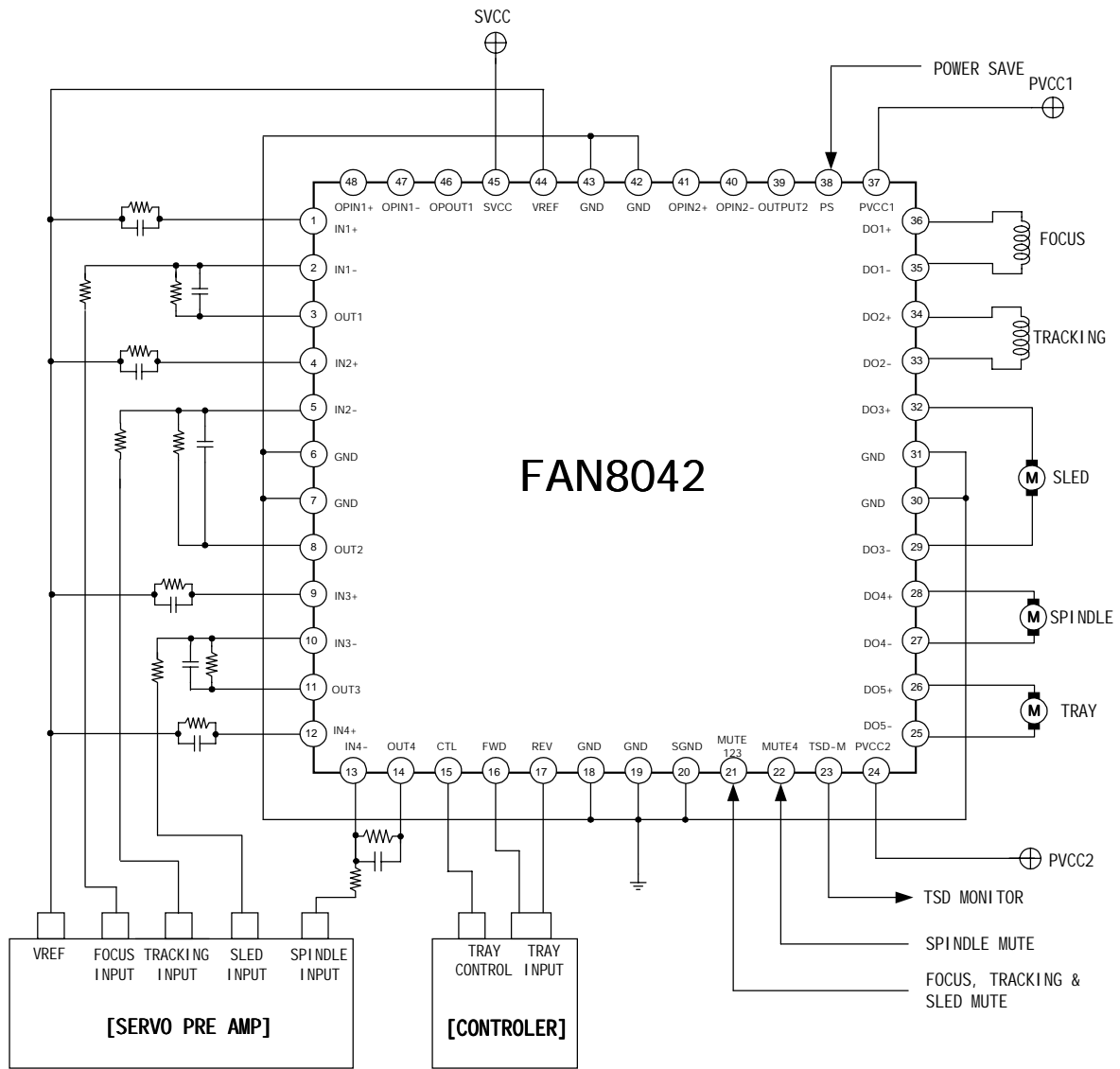

DISCLAIMER

FAIRCHILD SEMICONDUCTOR RESERVES THE RIGHT TO MAKE CHANGES WITHOUT FURTHER NOTICE TO ANY PRODUCTS HEREIN TO IMPROVE RELIABILITY, FUNCTION OR DESIGN. FAIRCHILD DOES NOT ASSUME ANY LIABILITY ARISING OUT OF THE APPLICATION OR USE OF ANY PRODUCT OR CIRCUIT DESCRIBED HEREIN; NEITHER DOES IT CONVEY ANY LICENSE UNDER ITS PATENT RIGHTS, NOR THE RIGHTS OF OTHERS.

LIFE SUPPORT POLICY

FAIRCHILD'S PRODUCTS ARE NOT AUTHORIZED FOR USE AS CRITICAL COMPONENTS IN LIFE SUPPORT DEVICES OR SYSTEMS WITHOUT THE EXPRESS WRITTEN APPROVAL OF THE PRESIDENT OF FAIRCHILD SEMICONDUCTOR CORPORATION. As used herein:

1. Life support devices or systems are devices or systems which, (a) are intended for surgical implant into the body, or (b) support or sustain life, and (c) whose failure to perform when properly used in accordance with instructions for use provided in the labeling, can be reasonably expected to result in a significant injury of the user.
2. A critical component in any component of a life support device or system whose failure to perform can be reasonably expected to cause the failure of the life support device or system, or to affect its safety or effectiveness.