

# COM-HM76

COM Express CPU Type 6 Module, Socket G2 for Intel® 2nd & 3rd Generation Core™ i7/i5/i3/Pentium®/Celeron® Processor, HM76, DDR3L, GbE, Rev. C1.0

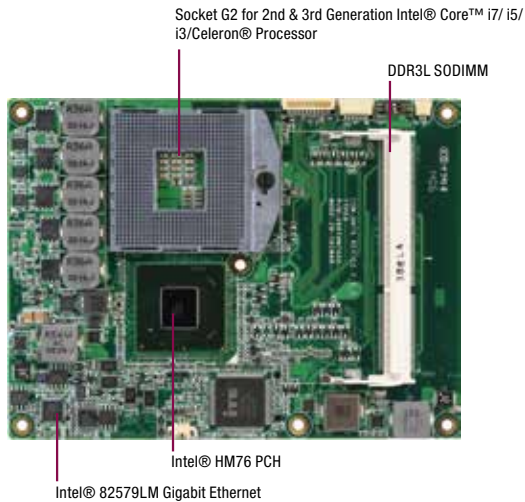

## Features

- Socket G2 for Intel® 2nd & 3rd Generation Core™ i7/i5/i3/Pentium®/Celeron® Processor
- Intel® HM76 PCH
- Single Channel SODIMM DDR3L 1333/1600 Memory, Max. 8 GB
- Gigabit Ethernet
- CRT, 18/24-bit Dual-channel LVDS, DDI x 2
- SATA x 4, USB3.0 x 4, USB2.0 x 8
- PCI-Express [x16] x 1, PCI-Express [x1] x 7
- COM Express Basic Module, Pin-out Type 6, COM.0 Rev. 2.1

## Specifications

System	
Form Factor	COM Express Basic module, Pin-out Type 6, COM. 0 Rev. 2.1
Processor	Socket G2 for Intel® 2nd & 3rd generation Core™ i7/i5/i3/Pentium®/Celeron® processor
System Memory	Single Channel SODIMM DDR3L 1333/1600 Memory, Max. 8 GB
Chipset	Intel® HM76
I/O Chipset	Intel® HM76
Ethernet	Intel® 82579LM for 10/1000/1000Base-TX
TPM	—
BIOS	AMI BIOS
Wake On LAN	Yes
Watchdog Timer	ITE8518E-L, 255 levels
H/W Status Monitoring	Supports CPU Temperature Monitoring.
Expansion Interface	PCI-Express [x16] x 1, PCI-Express [x1] x 7, LPC bus x 1, SMBUS x 1 UART x 2 (Tx/Rx only)
Power Requirement	Normal: +12V
Power Consumption (Typical)	Intel® i7-3610QE CPU @2.3 GHz, DDR3L 8 GB 2.73A@+12V, 1.18A@+5V, 0.31A@3.3V (w/ ECB-920A)
Board Size	4.92" x 3.75" (125mm x 95mm)
Gross Weight	0.66 lb (0.3 kg)
Operation Temperature	32 °F ~ 140 °F (0 °C ~ 60 °C)
Storage Temperature	-40 °F ~ 176 °F (-40 °C ~ 80 °C)
Operation Humidity	0% ~ 90% relative humidity, non-condensing
MTBF (Hours)	150,000
Display	
	LVDS, VGA, DDI x 2
Chipset	Intel® HM76 PCH
Memory	Shared system memory up to 512 MB
Resolution	Up to 2560 x 2048 for CRT (two display), 2048 x 1536 for three displays Up to 1920 x 1200 (UXGA) for LCD/HDMI Up to 2560 x 1600 for DP Up to 2548 x 1536 for DVI
LCD Interface	18/24-bit dual channel LVDS
I/O	
Storage	SATA x 4
Serial Port	Tx/Rx x 2 (Tx/Rx Only)
USB	USB2.0 x 8 (USB3.0 x 4)
Audio	High definition audio
GPIO	Up to 4 in and 4 out

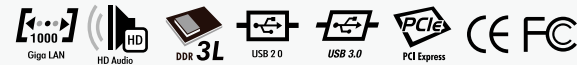

## Packing List

- M2.5 Screw x 4
- Product CD
- COM-HM76

## Optional Accessories

- **ECB-920A-A10**  
COMe Type 1/6/10 Carrier Board, ATX, GbE, 8USB, 2COM, 4SATA. PCIe, AT/ATX, Legacy Free, Rev. A1.0
- **PER-A129**  
Heat Spreader, For COM-HM76, Onboard CPU
- **PER-A115**  
CPU Cooler, 45W, for COM Express Basic Size. To be used with heat spreader

# COM-HM76

## Block Diagram Unit: mm

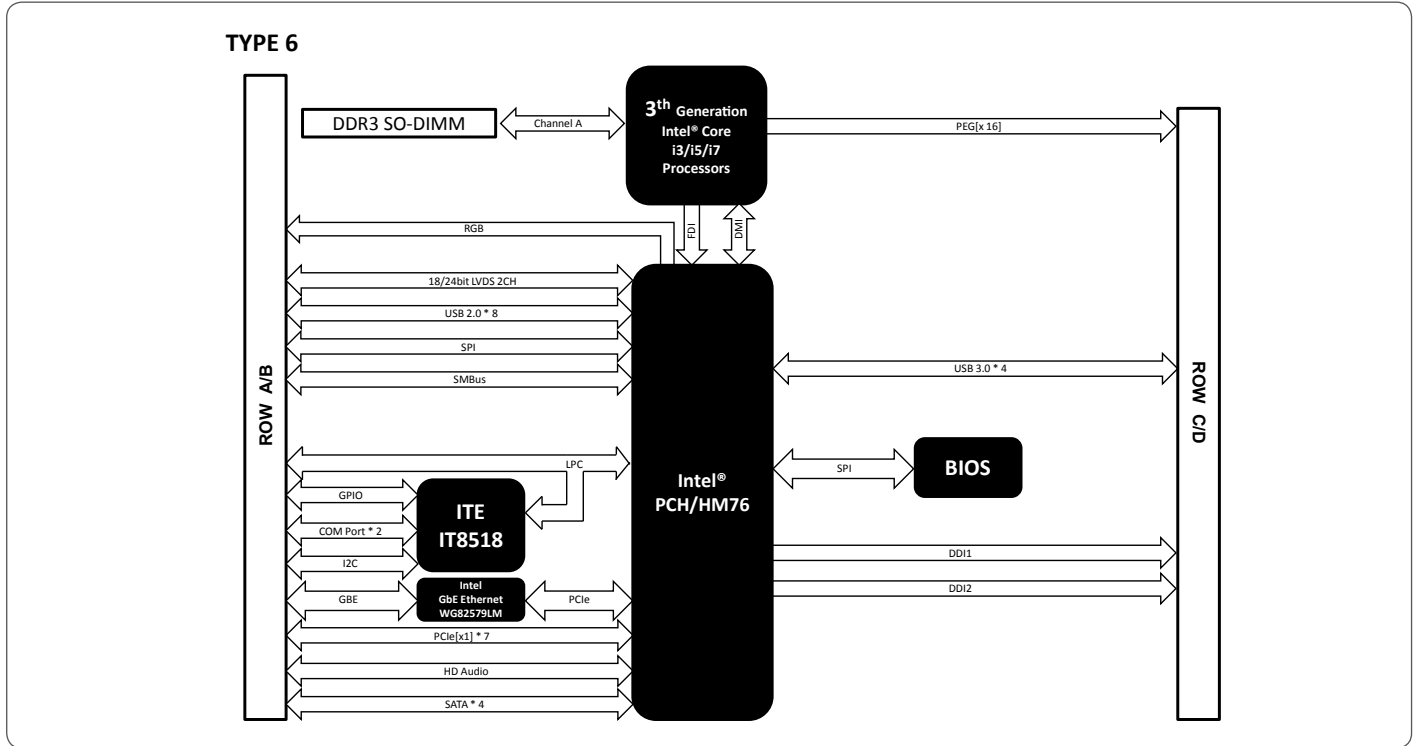

## Dimension Unit: mm

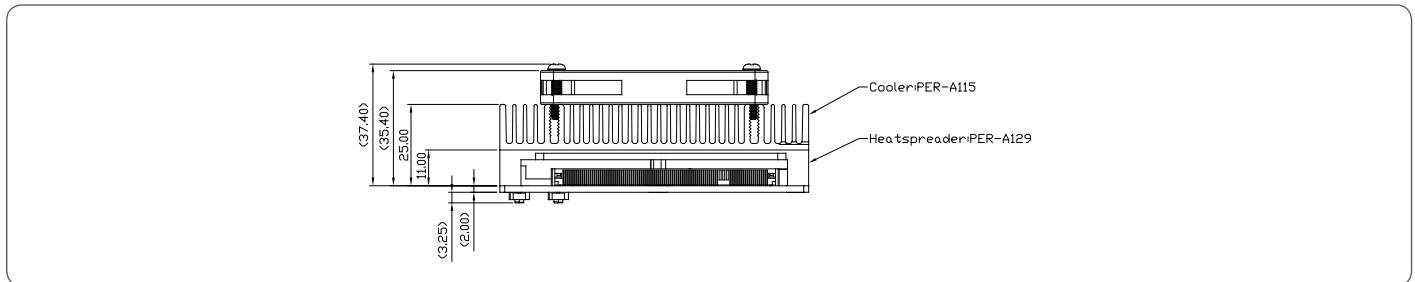

## Ordering Information

Part Number	COM Express Type	CPU	Memory	Display	LVDS	Storage	LAN	USB	URAT	Expansion Slot	Power	Temp
COM-HM76-C11	6 (COM.0 Rev. 2.1)	Socket G2 for 2nd & 3rd Generation Intel® Core™ i7/ i5/ i3/Celeron® Processor	DDR3L SODIMM x 1 Max. 8 GB	LVDS, VGA, DDI x 2	18/24b, 2CH	SATA x 4	GbE x 1	USB3.0 x 4 USB2.0 x 8	2 (Tx/Rx)	PCI-E [16] x 1, PCI-E [1] x 7	12V	0°C ~ 60°C