



HY2111

Data Sheet

1-Cell Lithium-ion/Lithium Polymer
Battery Packs Protection ICs

Table of Contents

1. GENERAL DESCRIPTION	4
2. FEATURES	4
3. APPLICATIONS	4
4. BLOCK DIAGRAM.....	5
5. ORDERING INFORMATION	6
6. MODEL LIST.....	6
7. PIN CONFIGURATION AND PACKAGE MARKING INFORMATION	7
8. ABSOLUTE MAXIMUM RATINGS	7
9. ELECTRICAL CHARACTERISTICS	8
10. BATTERY PROTECTION IC CONNECTION EXAMPLE.....	10
11. DESCRIPTION OF OPERATION.....	11
11.1. Normal Status.....	11
11.2. Overcharge Status	11
11.3. Overdischarge Status.....	12
11.4. Discharge Overcurrent Status (Discharge Overcurrent & Short Circuit).....	12
11.5. Charge Overcurrent Status	13
11.6. 0V Battery Charging Function “Available”	13
11.7. 0V Battery Charging Function “Unavailable”	14
12. CHARACTERISTICS (TYPICAL DATA).....	15
13. PACKAGE INFORMATION.....	18
14. TAPE & REEL INFORMATION.....	19
15. REVISION RECORD.....	20

Attention :

1. HYCON Technology Corp. reserves the right to change the content of this datasheet without further notice. For most up-to-date information, please constantly visit our website:
<http://www.hycontek.com> .
2. HYCON Technology Corp. is not responsible for problems caused by figures or application circuits narrated herein whose related industrial properties belong to third parties.
3. Specifications of any HYCON Technology Corp. products detailed or contained herein stipulate the performance, characteristics, and functions of the specified products in the independent state. We does not guarantee of the performance, characteristics, and functions of the specified products as placed in the customer's products or equipment. Constant and sufficient verification and evaluation is highly advised.
4. Please note the operating conditions of input voltage, output voltage and load current and ensure the IC internal power consumption does not exceed that of package tolerance. HYCON Technology Corp. assumes no responsibility for equipment failures that resulted from using products at values that exceed, even momentarily, rated values listed in products specifications of HYCON products specified herein.
5. Notwithstanding this product has built-in ESD protection circuit, please do not exert excessive static electricity to protection circuit.
6. Products specified or contained herein cannot be employed in applications which require extremely high levels of reliability, such as device or equipment affecting the human body, health/medical equipments, security systems, or any apparatus installed in aircrafts and other vehicles.
7. Despite the fact that HYCON Technology Corp. endeavors to enhance product quality as well as reliability in every possible way, failure or malfunction of semiconductor products may happen. Hence, users are strongly recommended to comply with safety design including redundancy and fire-precaution equipments to prevent any accidents and fires that may follow.
8. Use of the information described herein for other purposes and/or reproduction or copying without the permission of HYCON Technology Corp. is strictly prohibited.

1. General Description

The series of **HY2111** ICs is best created for single-cell lithium-ion/lithium polymer rechargeable battery protection and it also comprises high-accuracy voltage detectors and delay circuits.

These ICs are suitable for protecting single-cell rechargeable lithium-ion/lithium polymer battery packs against the problems of overcharge, overdischarge and overcurrent.

2. Features

The features that whole series of HY2111 comprised are as follows:

(1) High-accuracy voltage detection circuit

- Overcharge detection voltage 4.200 to 4.400V Accuracy: $\pm 25\text{mV}$
- Overcharge release voltage 3.900 to 4.400V Accuracy: $\pm 50\text{mV}$
- Overdischarge detection voltage 2.30 to 3.00V Accuracy: $\pm 80\text{mV}$
- Overdischarge release voltage 2.30 to 3.40V Accuracy: $\pm 80\text{mV}$
- Discharge overcurrent detection voltage (by option)
- Charge overcurrent detection voltage $-100\text{mV}(\text{fixed})$ Accuracy: $\pm 40\text{mV}$
- Short-circuiting detection voltage $0.85\text{V}(\text{fixed})$ Accuracy: $\pm 300\text{mV}$

(2) Delay times are generated by an internal circuit (external capacitors are unnecessary).

- Overcharge delay time 100ms typ.
- Overdischarge delay time 25ms typ.
- Discharge overcurrent delay time 10ms typ.
- Charge overcurrent detection voltage 12ms typ.
- Short circuit delay time $500\mu\text{s}$ typ.

(3) Power-down function “Yes” / “No” are selectable (See Model List).

(4) Auto overdischarge recovery function “Yes” / “No” are selectable (See Model List).

(5) Low current consumption (Products with Power-down Function)

- Operation mode $3.0\mu\text{A}$ typ., $6.0\mu\text{A}$ max. (VDD=3.9V)
- Ultra low power-down current at $0.1\mu\text{A}$ max. (VDD=2.0V)

(6) High-withstanding-voltage device is used for charger connection pins

(CS pin and OC pin : Absolute maximum rating = 20 V)

(7) 0V battery charge function “available” / “unavailable” are selectable (See Model List).

(8) Wide operation temperature range -40°C to $+85^{\circ}\text{C}$

(9) Small package SOT-23-6

(10) The HY2111 series are Halogen-free, green package

3. Applications

- 1-cell lithium-ion rechargeable battery packs
- 1-cell lithium polymer rechargeable battery packs

4. Block Diagram

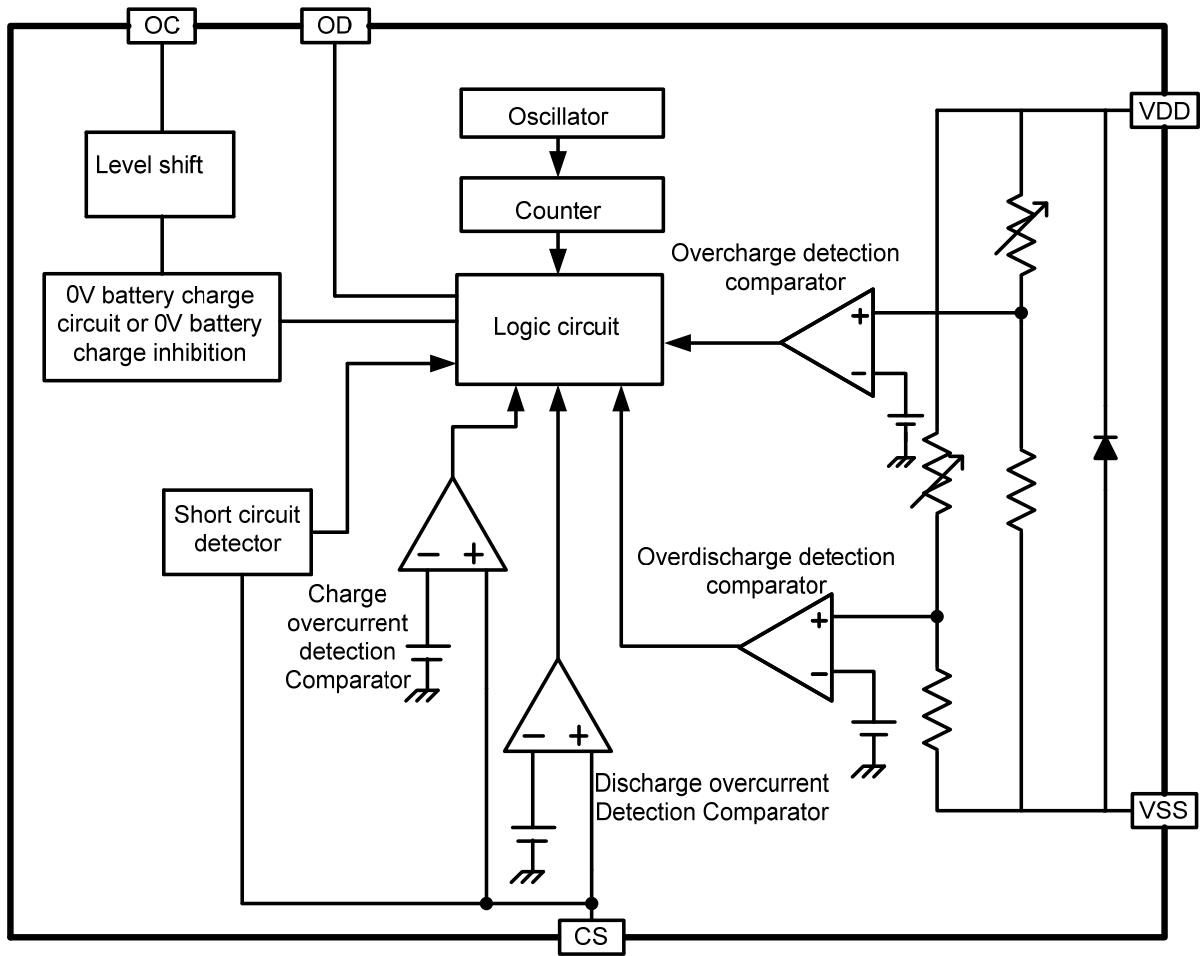

5. Ordering Information

- Product name define

HY2111-XX

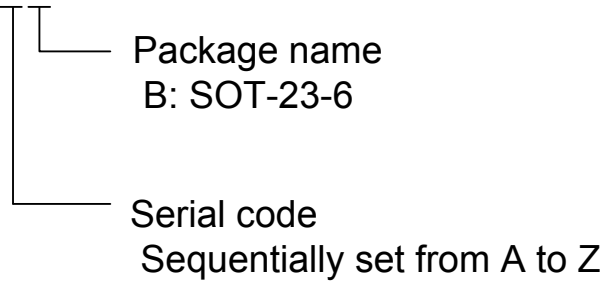

6. Model List

Model	Over charge detection voltage	Over charge release voltage	Over discharge detection voltage	Over discharge release voltage	Discharge overcurrent detection voltage	Charge overcurrent detection voltage	0V battery charge function	Other function
	V _{CU}	V _{CR}	V _{DL}	V _{DR}	V _{DIP}	V _{CIP}	V _{0CH}	-
HY2111-DB	4.28V	4.08V	2.90V	3.00V	75±25mV	-100mV	available	Power-down function
HY2111-EB	4.28V	4.08V	2.40V	2.50V	150±25mV	-100mV	available	Power-down function
HY2111-GB	4.28V	4.08V	2.90V	3.00V	150±25mV	-100mV	available	Power-down function
HY2111-HB	4.28V	4.08V	2.90V	3.00V	200±25mV	-100mV	available	Power-down function
HY2111-KB	4.28V	4.08V	2.40V	2.50V	225±30mV	-100mV	available	Auto overdischarge recovery function
HY2111-NB	4.28V	4.08V	2.90V	3.00V	150±25mV	-100mV	unavailable	Power-down function

Remark: Please contact our sales office for the products with detection voltage value other than those specified above.

7. Pin Configuration and Package Marking Information

Pin No.	Symbol	Description
1	OD	MOSFET gate connection pin for discharge control
2	CS	Input pin for current sense, charger detect pin
3	OC	MOSFET gate connection pin for charge control
4	NC	No connection.
5	VDD	Power supply pin
6	VSS	Ground pin



11 : Product Name
 XB : Serial code & Package name
 XXXX : Date code

8. Absolute Maximum Ratings

(VSS=0V, Ta=25°C unless otherwise specified)

Item	Symbol	Rating	Unit
Input voltage between VDD and VSS pin	V _{DD}	VSS-0.3 to VSS+10	V
OC output pin voltage	V _{OC}	VDD-20 to VDD+0.3	V
OD output pin voltage	V _{OD}	VSS-0.3 to VDD+0.3	V
CS input pin voltage	V _{CS}	VDD-20 to VDD+0.3	V
Operating Temperature Range	T _{OP}	-40 to +85	°C
Storage Temperature Range	T _{ST}	-40 to +125	°C
Power dissipation	P _D	250	mW

9. Electrical Characteristics

(VSS=0V, Ta=25°C unless otherwise specified)

Item	Symbol	Condition	Min.	Typ.	Max.	Unit
SUPPLY POWER RANGE						
Operating voltage between VDD pin and VSS pin	V _{DSOP1}	-	1.5	-	8	V
Operating voltage between VDD pin and CS pin	V _{DSOP2}	-	1.5	-	20	V
CURRENT CONSUMPTION (with Power-down Function)						
Supply Current	I _{DD}	V _{DD} =3.9V	-	3.0	6.0	μA
Power-Down Current	I _{PD}	V _{DD} =2.0V	-	-	0.1	μA
CURRENT CONSUMPTION (with Auto Overdischarge Recovery Function)						
Supply Current	I _{DD}	V _{DD} =3.9V	-	3.0	6.0	μA
Overdischarge Current Consumption	I _{OD}	V _{DD} =2.0V	-	2.0	3.0	μA
DETECTION VOLTAGE						
Overcharge Detection Voltage	V _{CU}	4.2V to 4.4V adjustable	V _{CU} -0.025	V _{CU}	V _{CU} +0.025	V
		4.2V to 4.4V adjustable -5°C to +55°C (Note)	V _{CU} -0.035	V _{CU}	V _{CU} +0.035	V
Overcharge Release Voltage	V _{CR}	3.9V to 4.4V adjustable	V _{CR} -0.05	V _{CR}	V _{CR} +0.05	V
Overdischarge Detection Voltage	V _{DL}	2.3V to 3.0V adjustable	V _{DL} -0.08	V _{DL}	V _{DL} +0.08	V
Overdischarge Release Voltage	V _{DR}	2.3V to 3.4V adjustable	V _{DR} -0.08	V _{DR}	V _{DR} +0.08	V
Discharge Overcurrent Detection Voltage	V _{DIP}	V _{DD} =3.6V, 50mV < V _{DIP} < 225mV	V _{DIP} -25	V _{DIP}	V _{DIP} +25	mV
		V _{DD} =3.6V, V _{DIP} ≥ 225mV	V _{DIP} -30	V _{DIP}	V _{DIP} +30	mV
Short Circuit Detection Voltage	V _{SIP}	V _{DD} =3.0V	0.55	0.85	1.15	V
Charge overcurrent detection voltage	V _{CIP}		-140	-100	-60	mV
DELAY TIME						
Overcharge Delay Time	T _{OC}		50	100	150	ms
Overdischarge Delay Time	T _{OD}	V _{DD} =3.6V to 2.0V	10	25	40	ms
Discharge Overcurrent Delay Time	T _{DIP}	V _{DD} =3.6V	5	10	15	ms
Charge Overcurrent Delay Time	T _{CIP}	V _{DD} =3.6V, CS=-0.2V	7	12	17	ms
Short Circuit Delay Time	T _{SIP}	V _{DD} =3.0V	-	500	700	μs
CONTROL OUTPUT VOLTAGE(OD&OC)						
OD Pin Output "H" Voltage	V _{DH}		V _{DD} -0.1	V _{DD} -0.02	-	V
OD Pin Output "L" Voltage	V _{DL}		-	0.1	0.5	V
OC Pin Output "H" Voltage	V _{CH}		V _{DD} -0.1	V _{DD} -0.02	-	V

OC Pin Output "L" Voltage	V_{CL}		-	0.1	0.5	V
0V BATTERY CHARGE FUNCTION						
0V battery charge starting charger voltage	V_{0CH}	0V battery charging function "available"	1.2	-	-	V
0V battery charge inhibition charger voltage	V_{0IN}	0V battery charging function "unavailable"	-	-	0.5	V

NOTE: Since products are not screened at high and low temperature, the specification for this temperature range is guaranteed by design, not tested in production.

10. Battery Protection IC Connection Example

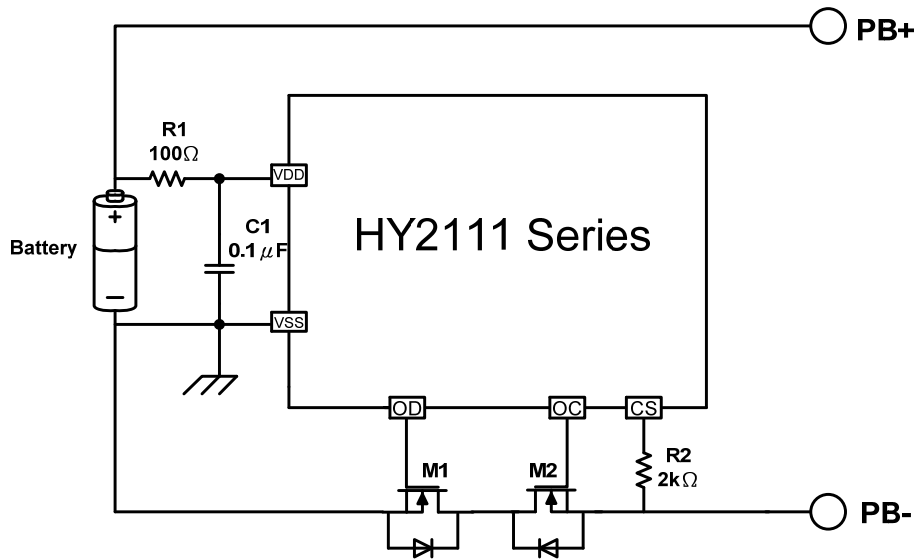

Symbol	Device Name	Purpose	Min.	Typ.	Max.	Remark
R1	Resistor	limit current, stabilize VDD and strengthen ESD protection	100Ω	100Ω	200Ω	*1
R2	Resistor	limit current	1kΩ	2kΩ	2kΩ	*2
C1	Capacitor	stabilize VDD	0.01μF	0.1μF	1.0μF	*3
M1	N-MOSFET	Discharge control	-	-	-	*4
M2	N-MOSFET	Charge control	-	-	-	*5

- *1. R1 should be as small as possible to avoid lowering the overcharge detection accuracy due to current consumption. When a charger is connected in reversed, the current flows from the charger to the IC. At this time, if R1 is connected to high resistance, the voltage between VDD pin and VSS pin may exceed the absolute maximum rating.
- *2. If R2 has a resistance higher than 2kΩ, the charging current may not be cut when a high-voltage charger is connected. Please select as large a resistance as possible to prevent current when a charger is connected in reversed.
- *3. C1 will stabilize the supply voltage of VDD, the value of C1 should be equal to or more than 0.01μF.
- *4. If a FET with a threshold voltage equal to or higher than the overdischarge detection voltage is applied, discharging may be stopped before overdischarge is detected.
- *5. If the withstanding voltage between the gate and source is lower than the charger voltage, the FET may be destroyed.

Caution :

1. The above constants may be changed without notice · please download the most up-to-date datasheet on our website. <http://www.hycontek.com>
2. It is advised to perform thorough evaluation and test if peripheral devices need to be adjusted.

11. Description of Operation

11.1. Normal Status

This IC monitors the voltage of the battery connected between the VDD pin and VSS pin and the voltage difference between the CS pin and VSS pin to control charging and discharging.

When the battery voltage is in the range from overdischarge detection voltage (V_{DL}) to overcharge detection voltage (V_{CU}), and the CS pin voltage is in the range from the charge overcurrent detection voltage (V_{CIP}) to discharge overcurrent detection voltage (V_{DIP}), the IC turns both the charging and discharging control MOSFET on. This condition is called the normal status. Under this condition, charging and discharging can both be carried out freely.

Notice:

Discharging may not be enacted when the battery is first time connected. To regain normal status, CS pin and VSS pin must be shorted or the charger must be connected.

11.2. Overcharge Status

Under the normal status, as soon as the battery voltage becomes higher than the overcharge detection voltage (V_{CU}) during charging and the detection continues longer than the overcharge detection delay time (T_{OC}), the HY2111 series will turn the charging control MOSFET off (OC pin) to stop charging. This condition is called the overcharge status.

The overcharge status can be released by the following two cases:

Condition: disconnect charger

(1) The voltage of the battery cell is equal to or lower than the overcharge release voltage (V_{CR}) due to self-discharge.

(2) When the load is connected, the discharge current will pass through parasitical diode of charging control MOSFET. At this time, CS pin will detect "Diode forward voltage drop (V_f)". When CS pin voltage rises higher than discharge overcurrent detection voltage (V_{DIP}) and battery voltage lowers than overcharge detection voltage (V_{CU}), the overcharge status will be released and back to normal status.

Caution:

When a charger is connected after overcharge detection, the overcharge status is not released even if the battery voltage is below overcharge release voltage (V_{CR}). The overcharge status is released when the CS pin voltage goes over the charge overcurrent detection voltage (V_{CIP}) by removing the charger.

11.3. Overdischarge Status

11.3.1. Products with Power-down Function

When the battery voltage falls below than the overdischarge detection voltage (V_{DL}) during discharging in the normal status and the detection continues longer than the overdischarge detection delay time (T_{OD}), the HY2111 series will turn the discharging control MOSFET off (OD pin) so as to stop discharging. This condition is called the overdischarge status.

When the MOSFET is off, CS pin voltage is pulled up by the resistor to VDD in the IC, at this time, the power consumption is reduced to the lowest. This condition is called the "SLEEP MODE".

The overdischarge status will be released by two cases:

- (1) When CS pin voltage is equal to or lower than the charge overcurrent detection voltage (V_{CIP}) by charging and the VDD pin voltage is higher than the overdischarge detection voltage (V_{DL}).
- (2) When CS pin voltage is equal to or higher than the charge overcurrent detection voltage (V_{CIP}) by charging and the VDD pin voltage is higher than the overdischarge release voltage (V_{DR}).

11.3.2. Products with Auto Overdischarge Recovery Function

When the battery voltage falls below than the overdischarge detection voltage (V_{DL}) during discharging in the normal status and the detection continues longer than the overdischarge detection delay time (T_{OD}), the HY2111 series will turn the discharging control MOSFET off (OD pin) so as to stop discharging. This condition is called the overdischarge status.

The overdischarge status will be released by three cases:

- (1) When CS pin voltage is equal to or lower than the charge overcurrent detection voltage (V_{CIP}) by charging and the VDD pin voltage is higher than the overdischarge detection voltage (V_{DL}).
- (2) When CS pin voltage is equal to or higher than the charge overcurrent detection voltage (V_{CIP}) by charging and the VDD pin voltage is higher than the overdischarge release voltage (V_{DR}).
- (3) Without connecting a charger, if the VDD pin voltage is higher than overdischarge release voltage (V_{DR}), the overdischarge status will be released, namely Auto Overdischarge Recovery Function .

11.4. Discharge Overcurrent Status (Discharge Overcurrent & Short Circuit)

Under normal condition, the HY2111 continuously monitors the discharge current by sensing the voltage of CS pin. If the voltage of CS pin exceeds the overcurrent detection voltage (V_{DIP}) and the condition lasts beyond the overcurrent delay time (T_{DIP}),

discharging will be suspended by turning off the discharge control MOSFET (OD pin). This condition is called the discharge overcurrent status.

If the voltage of CS pin exceeds the short circuit detection voltage (V_{SIP}) and the condition lasts beyond the short circuit delay time (T_{SIP}), discharging will be suspended by turning off the discharge control MOSFET (OD pin). This condition is called the short circuit status.

When the impedance between PB+ and PB- is higher than discharge overcurrent and short circuit release impedance, the discharge overcurrent status and short circuit status will be released and back to normal operation status. In addition, if the impedance between PB+ and PB- is less than discharge overcurrent and short circuit release impedance, CS pin voltage will descend below than overcurrent detection voltage (V_{DIP}) after the charger is being connected, discharge overcurrent status and short circuit status will be released and back to normal operation status.

Equation of discharge overcurrent/short circuit release impedance: $[(150\text{mV}/V_{DIP}) * 450\text{k}\Omega]$ (typ.)

Caution:

- (1) Discharge overcurrent/short circuit release impedance is related to battery voltage VDD and overcurrent detection voltage (V_{DIP}).
- (2) If the charger is connected incautiously in reversed, the current direction is the same as discharge current in the circuit. If CS pin voltage goes higher than overcurrent detection voltage (V_{DIP}), it will enter into discharge overcurrent protection status to block out in-circuit current.

11.5. Charge Overcurrent Status

When a battery is in the normal status, the voltage of the CS pin is lower than the charge overcurrent detection voltage (V_{CIP}). When the charge current is higher than the specified value and the status lasts beyond the charge overcurrent detection delay time (T_{CIP}), the charge control MOSFET will be turned off and charging is stopped. This status is called the charge overcurrent status.

This IC will be restored to the normal status from the charge overcurrent status when the voltage at the CS pin returns to charge overcurrent detection voltage (V_{CIP}) or higher by removing the charger.

11.6. 0V Battery Charging Function “Available”

This function is used to recharge a connected battery which voltage is 0V due to self-discharge. When the 0V battery charge starting charger voltage (V_{0CH}) or a higher voltage is applied between the battery+ (PB+) and battery- (PB-) pins by connecting a charger, the charging control MOSFET gate is fixed to the VDD pin voltage.

When the voltage between the gate and the source of the charging control MOSFET becomes equal to or higher than the turn on voltage due to the charger voltage, the

charging control MOSFET is turned on to initiate charging. At this time, the discharging control MOSFET is off and the charging current flows through the internal parasitic diode in the discharging control MOSFET. When the battery voltage becomes equal to or higher than overdischarge detection voltage (V_{DL}), the HY2111 series will enter into the normal status.

Caution

(1) Some battery providers do not recommend charging for a completely self-discharged battery. Please ask the battery provider to determine whether to enable or prohibit the 0V battery charging function.

(2) The 0V battery charge function has higher priority than the charge overcurrent detection function. Consequently, a product in which use of the 0V battery charging function is enabled to forcibly charge a battery and the charge current cannot be detected when the battery voltage is lower than overdischarge detection voltage (V_{DL}).

11.7. 0V Battery Charging Function “Unavailable”

When a battery that is internally short-circuited (0V battery) is connected, the unavailable 0V charging function will prohibit recharging. When the battery voltage equals to the 0V battery charge inhibition battery voltage (V_{0IN}) or lower, the charging control MOSFET gate is fixed to the PB- pin voltage to prohibit charging. When the battery voltage equals to the 0V battery charge inhibition battery voltage (V_{0IN}) or higher, charging can be implemented.

Caution

(1) Some battery providers do not recommend charging for a completely self-discharged battery. Please ask the battery provider to determine whether to enable or prohibit the 0V battery charging function.

12. Characteristics (Typical Data)

1. Overcharge Detection / Release Voltage, Overdischarge Detection / Release Voltage, Discharge Overcurrent Detection Voltage , Short Circuit Detection Voltage ,Charge Overcurrent Detection Voltage, and Delay Time

(1) V_{CU} vs. T_a

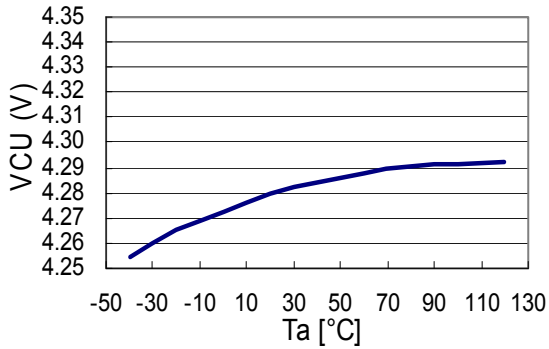

(2) V_{CR} vs. T_a

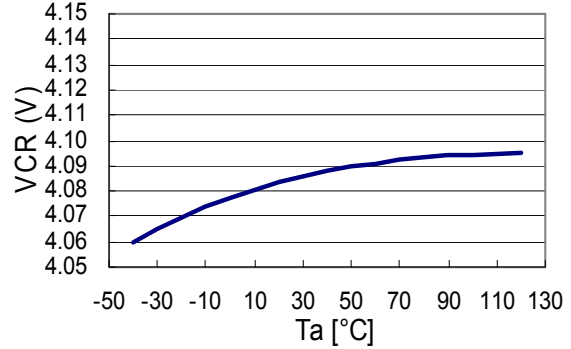

(3) V_{DL} vs. T_a

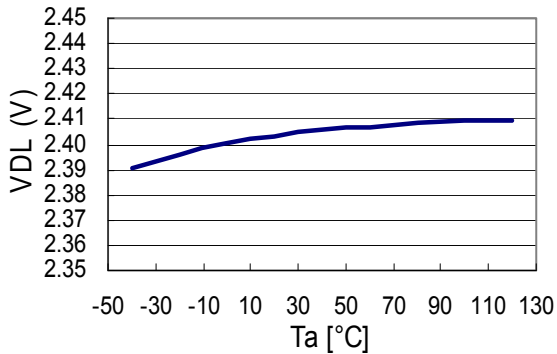

(4) V_{DR} vs. T_a

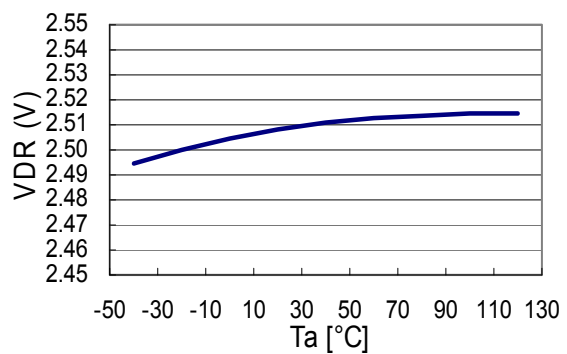

(5) T_{OC} vs. T_a

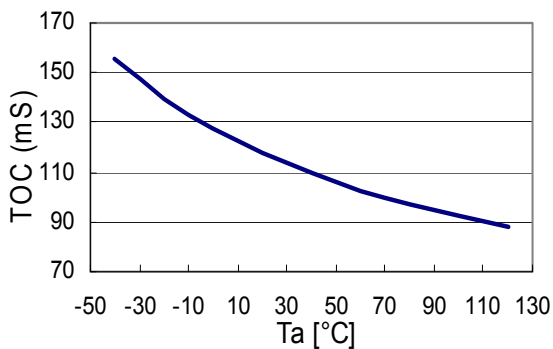

(6) T_{OD} vs. T_a

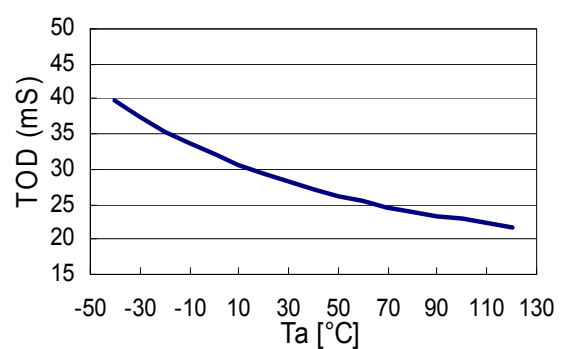

(7) V_{DIP} vs. T_a

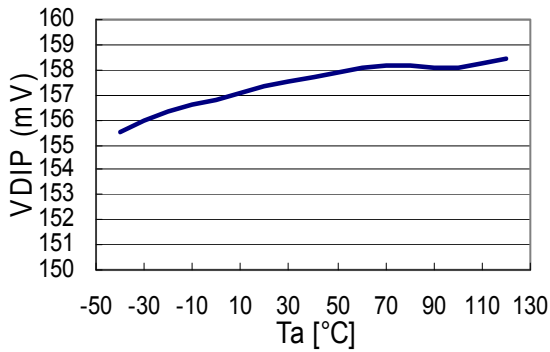

(8) T_{DIP} vs. T_a

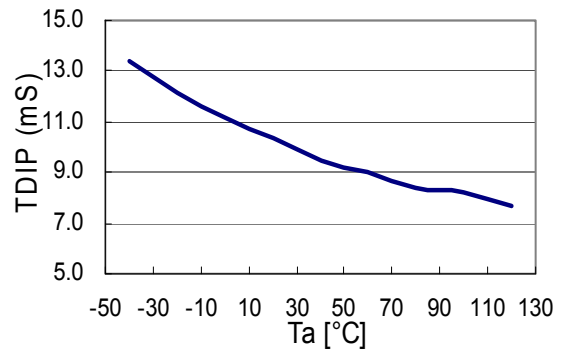

(9) V_{SIP} vs. T_a

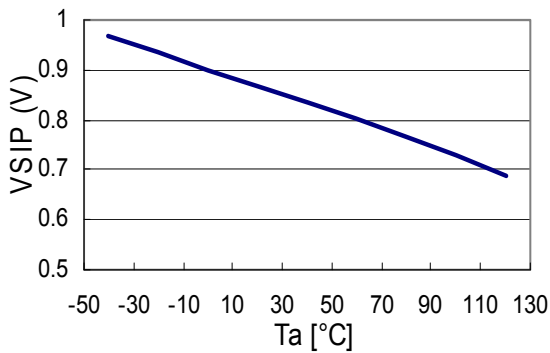

(10) T_{SIP} vs. T_a

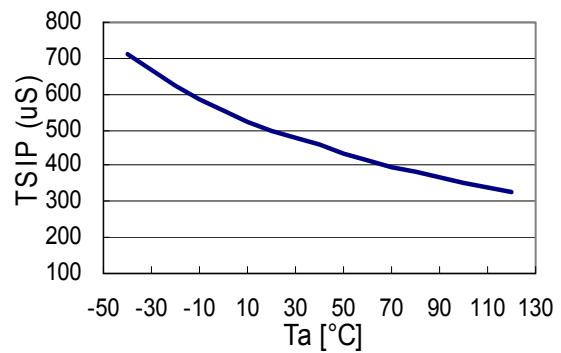

(11) V_{CIP} vs. T_a

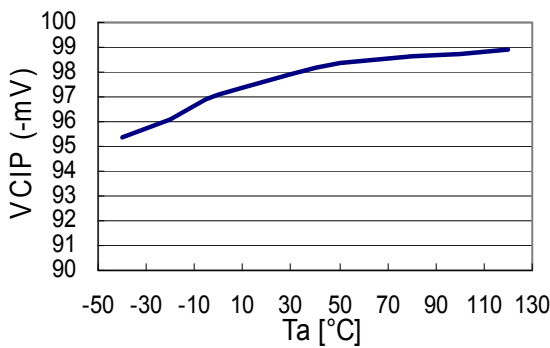

(12) T_{CIP} vs. T_a

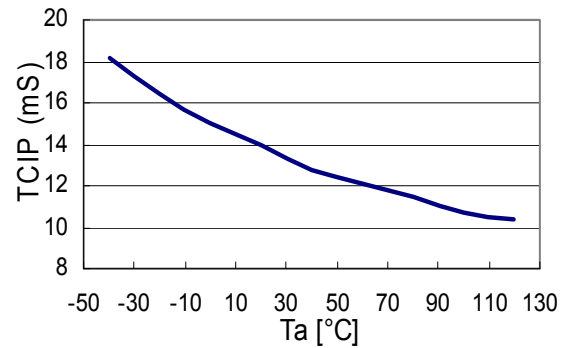

2. Current Consumption

(13) I_{DD} vs. T_a

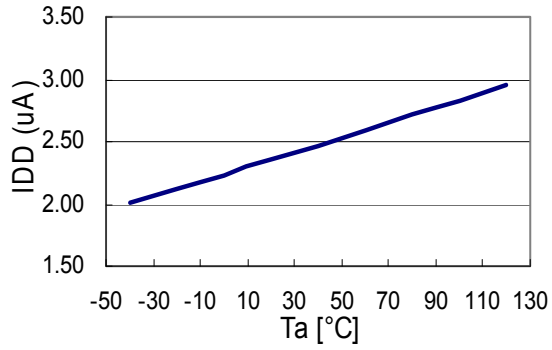

(14) I_{PD} vs. T_a

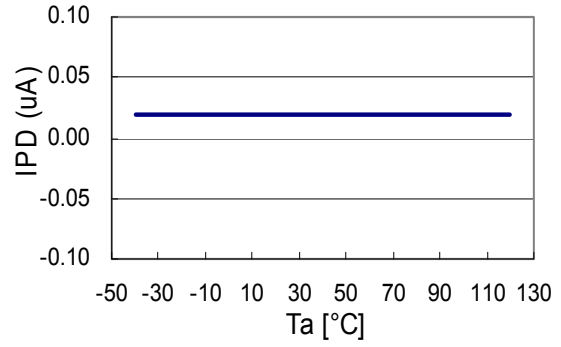

13. Package information

NOTE: All dimensions are in millimeters.

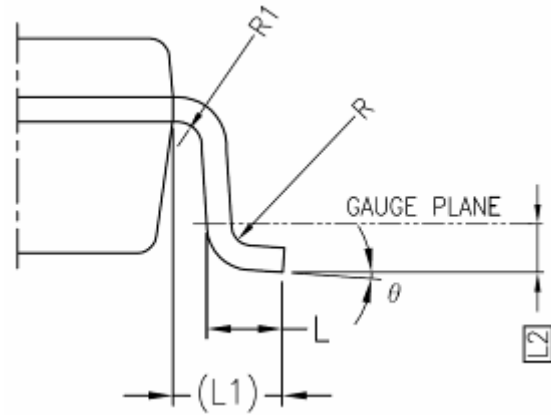
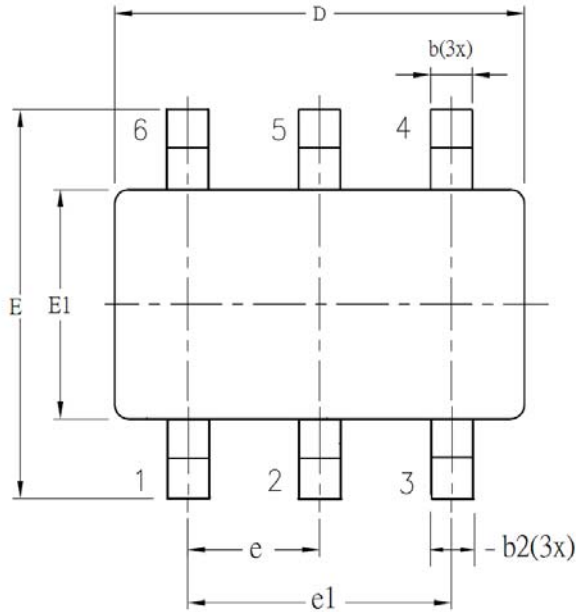

SYM BOL	ALL DIMENSIONS IN MILLIMETERS		
	MINIMUM	NOMINAL	MAXIMUM
A	-	1.30	1.40
A1	0	-	0.15
A2	0.90	1.20	1.30
b	0.30	-	0.50
b1	0.30	0.40	0.45
b2	0.30	0.40	0.50
c	0.08	-	0.22
c1	0.08	0.13	0.20
D	2.90 BSC		
E	2.80 BSC		
E1	1.60 BSC		
e	0.95 BSC		
e1	1.90 BSC		
L	0.30	0.45	0.60
L1	0.60 REF		
L2	0.25 BSC		
R	0.10	-	-
R1	0.10	-	0.25
θ	0°	4°	8°
$\theta 1$	5°	-	15°
$\theta 2$	5°	-	15°

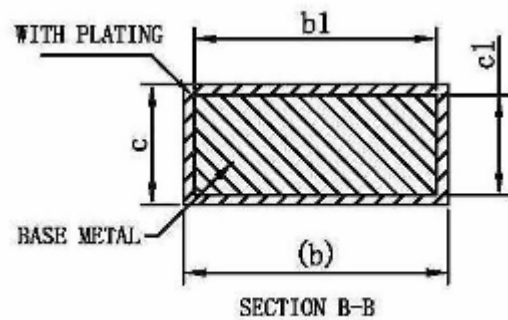
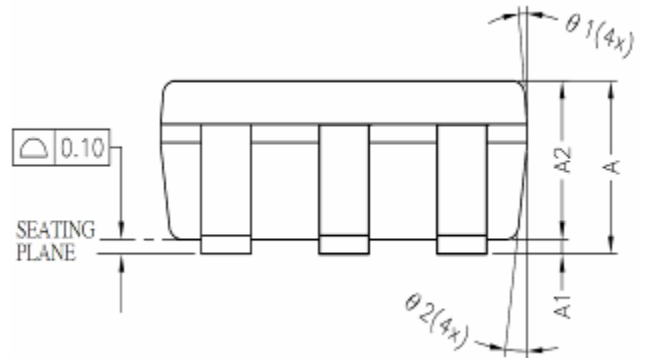

14. Tape & Reel Information

14.1. Tape & Reel Information---SOT-23-6

Unit : mm

14.1.1. Reel Dimensions

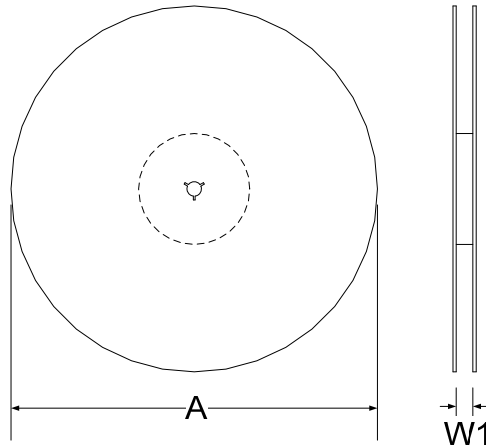

14.1.2. Carrier Tape Dimensions

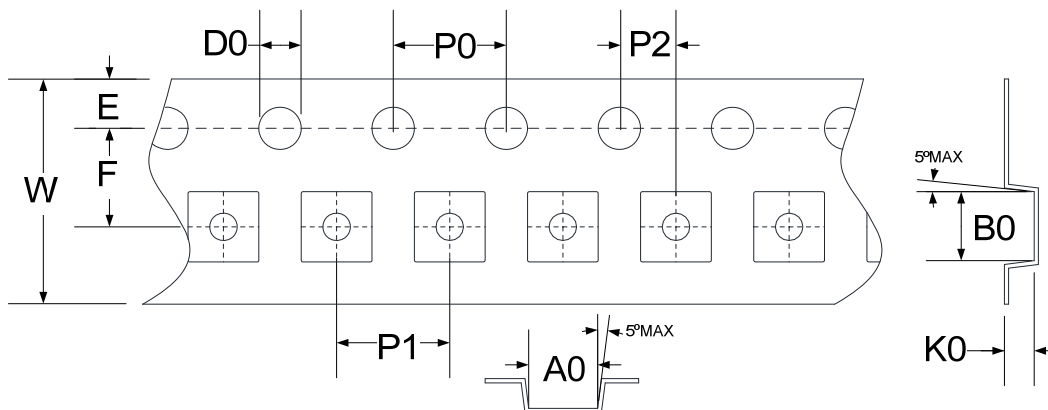

SYMBOLS	Reel Dimensions		Carrier Tape Dimensions									
	A	W1	A0	B0	K0	P0	P1	P2	E	F	D0	W
Spec.	178	9.0	3.35	3.25	1.50	4.00	4.00	2.00	1.75	3.50	1.50	8.00
Tolerance	±0.50	+1.50/-0	±0.10	±0.10	±0.10	±0.10	±0.10	±0.10	±0.05	±0.10	±0.05	+0.1/-0 ±0.20

Note: 10 Sprocket hole pitch cumulative tolerance is ±0.20mm.

14.1.3. PIN1 direction

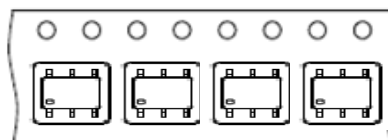

15. Revision Record

Major differences are stated thereafter:

Version	Page	Revision Summary
V09	All	The forth pin of HY2111 in SOT-23-6 package is amended as NC.
	All	Add in new model no.:HY2111-KA and HY2111-KB.
	19,20	Revise package size.
V10	All	Add in new model no.:HY2111-LA and HY2111-LB.
V11	All	Add in new model no.:HY2111-MA and HY2111-MB.
	10	Revise R1 & R2 select range
	19	Revise package size.
V12	All	Revised VDIP parameter of HY2111-KA & HY2111-KB to $225\text{mV} \pm 30\text{mV}$ and added in Auto overdischarge recovery function.
V13	All	Revise some of the electrical characteristic ranges. Delete DFN6 package that was marked as "A" and add in size spec of DFN6 package that marked as "C".
V14	All	Delete DFN6 package that was marked as "C" and add in size spec of DFN6 package that marked as "A".
V15	6	Remove some models.
	7	Revise SOT-23-6 package marking rule.
	All	Remove DFN6 package type that marked as "A".
V16	All	Add in new model no.:HY2111-NB.
		Delete SOT-23-6 (type 2) package .
V17	All	Add in Tape & Reel information.