

HIGH FREQUENCY MAGNETICS

T1/E1 Octal Transformer Module

TM02136

- Optimized for PMC Sierra PM4318
- Eight transformers and four common mode chokes in one surface mount package
- Interchangeable with S553-6500-D4 which has no common mode chokes
- Choke performance optimized for T1 and E1 applications (see table)
- Meets ITU-T G.703 return loss from -40° to +85° C from 51 kHz to 3.072 MHz
- Operating temperature range -40° to +85°C
- Meets IEC 695, 2-2 flammability requirements
- PWB Process Capability: standard printed wiring board assembly techniques, total-immersion cleaning
- Reliability testing: Shock, vibration, temperature cycling, temperature - humidity - bias
- Interwinding breakdown voltage: 1500 Vrms min
- UL 1950 approved: file number E150991

ELECTRICAL SPECIFICATIONS at 25° C

Part Number	Turns Ratio ±2%		Primary Inductance at 10 kHz		Leakage Inductance at 1 MHz		DCR Ω max				Capacitance C w/w	Return Loss at 102 kHz 120Ω Application ¹				
	IC : Line		mH min		μH max		IC Side		Line Side		pF max	25° C dB typ		-40 to +85° C dB min		
	TX	RX	TX	RX	TX	RX	TX	RX	TX	RX		TX	RX	TX	RX	
S553-6500-F6	1 : 2	1 : 2	1.5	1.5	0.3	0.3	0.7	0.7	2.0	1.3	35	20	21	18	18	
Common mode attenuation for transmit interface is centered at 24th harmonic of T1 and E1 clock frequencies:																
S553-6500-F6	41 dB typical at 37 MHz (T1 harmonic)						41 dB typical at 49 MHz (E1 harmonic)									

1. Terminated in 36 Ω for TX and 27 Ω for RX

SCHEMATIC

S553-6500-F6

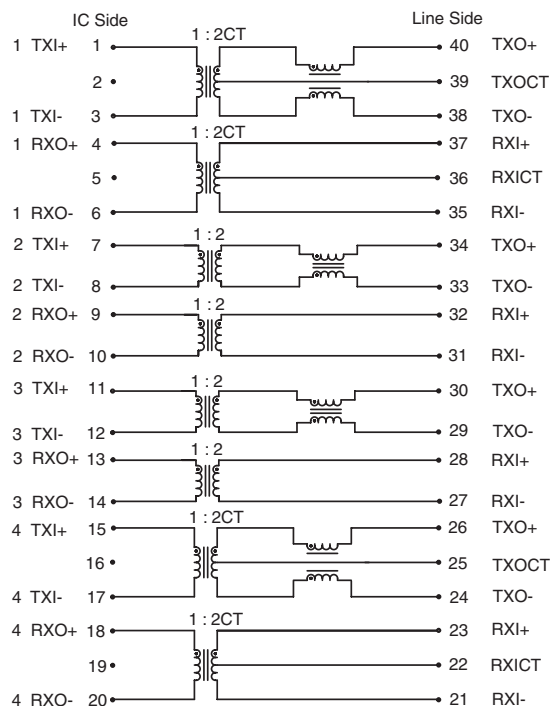

©2002 Bel Fuse Inc. Specifications subject to change without notice. 06.02

MECHANICAL

S553-6500-F6

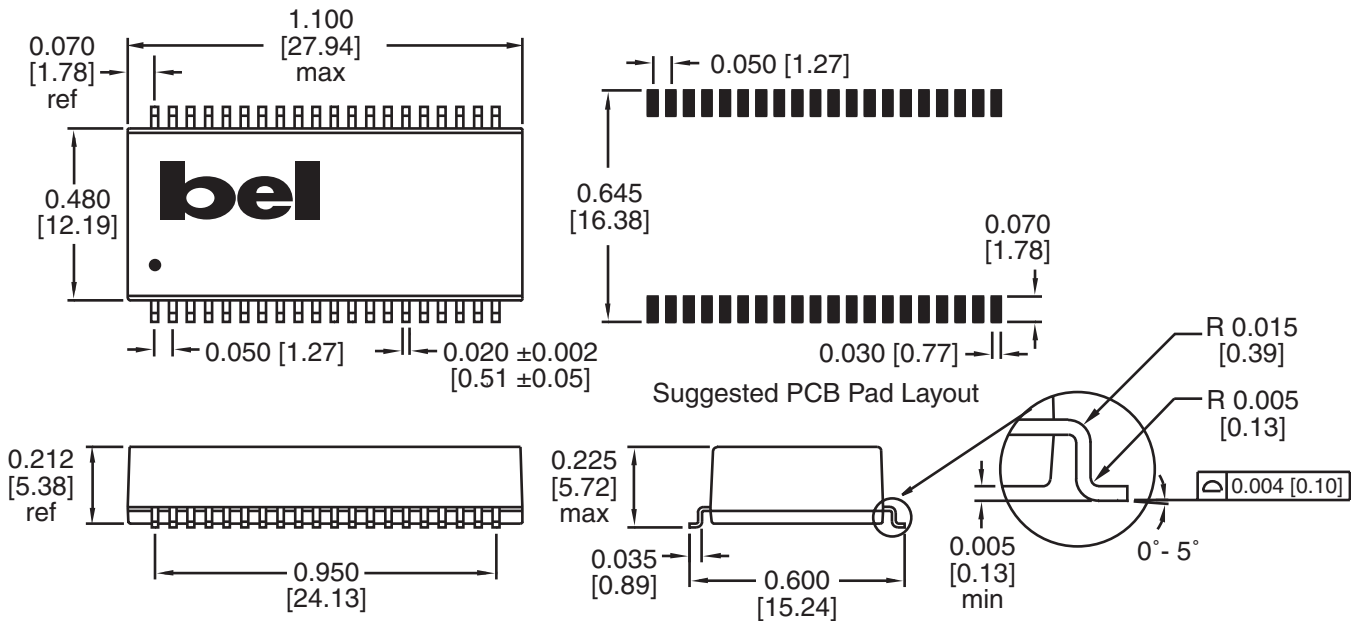

Dimensions are in inches [millimeters].
Standard dimension tolerance is ±0.005 [0.13] unless otherwise noted.

Tape and Reel Packaging

44 mm wide by 24 mm pitch; 13 inch OD, 6 inch ID
200 modules per reel, maximum
Meets ANSI/EIA 481-2 Carrier Tape Standards - JEDEC SO Package

CORPORATE

Bel Fuse Inc.
206 Van Vorst Street
Jersey City, NJ 07302
Tel 201-432-0463
Fax 201-432-9542
www.belfuse.com

FAR EAST

Bel Fuse Ltd.
8F / 8 Luk Hop Street
San Po Kong
Kowloon, Hong Kong
Tel 852-2328-5515
Fax 852-2352-3706
www.belfuse.com

EUROPE

Bel Fuse Europe Ltd.
Preston Technology Management Centre
Marsh Lane, Suite G7, Preston
Lancashire, PR1 8UD, U.K.
Tel 44-1772-556601
Fax 44-1772-888366
www.belfuse.com