

# Customer Information Sheet

DRAWING No.: Z80-299

SHEET 2 OF 2

IF IN DOUBT - ASK

©

NOT TO SCALE

THIRD ANGLE PROJECTION

ALL DIMENSIONS IN mm

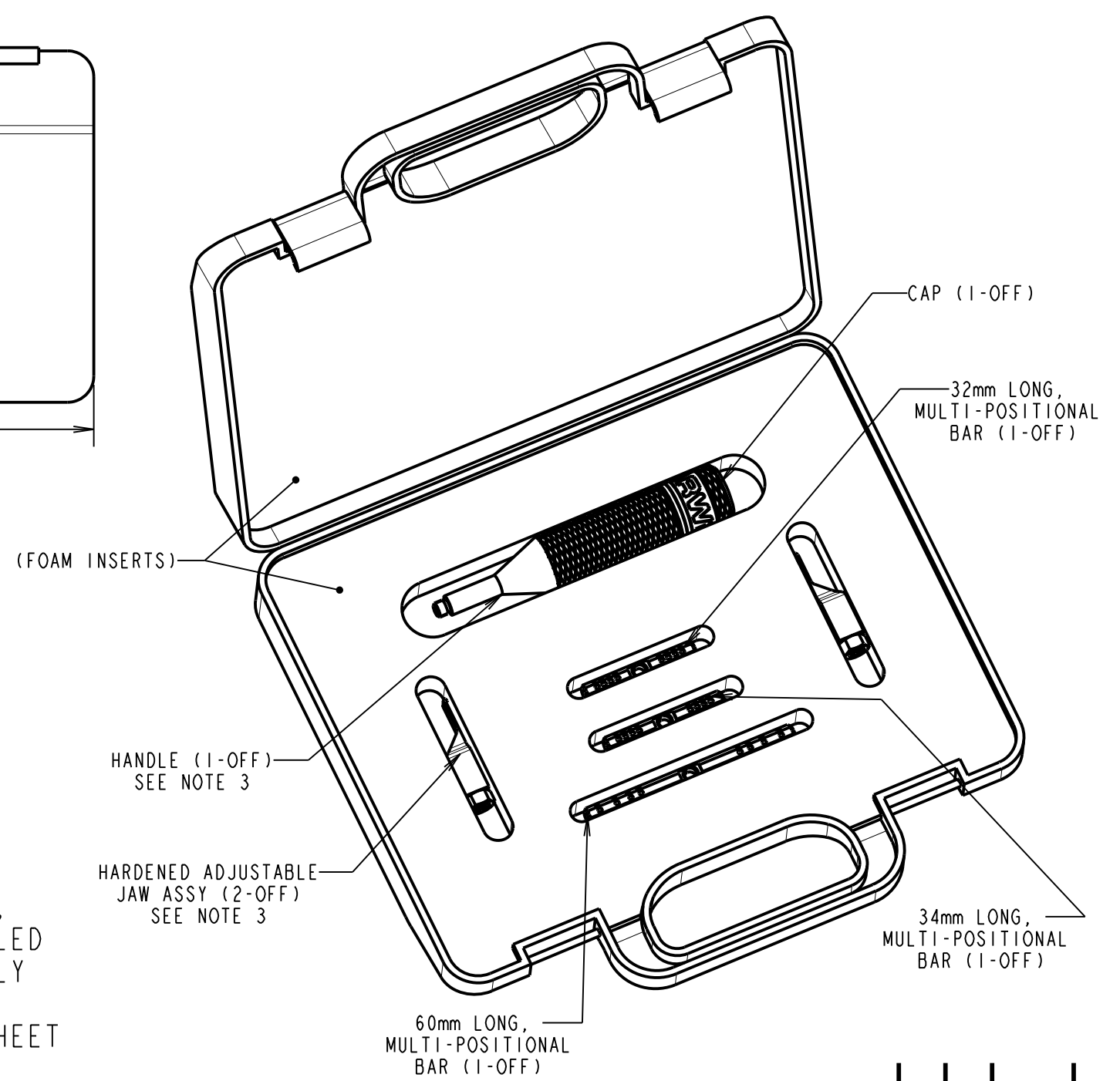
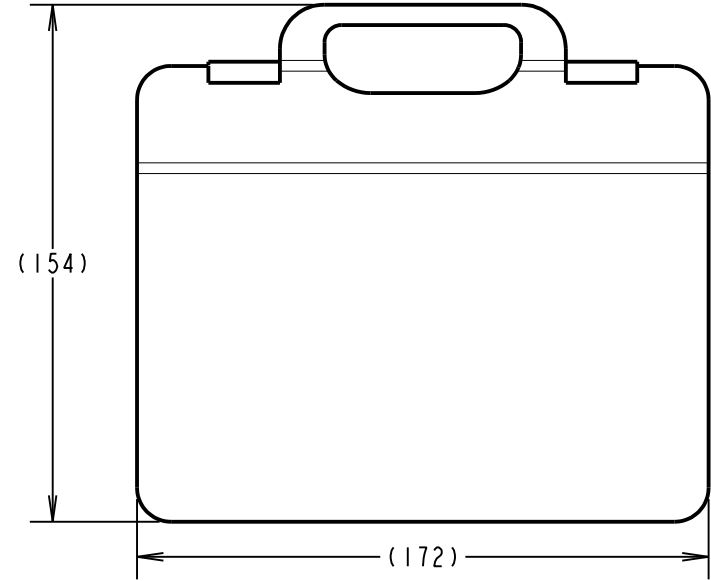
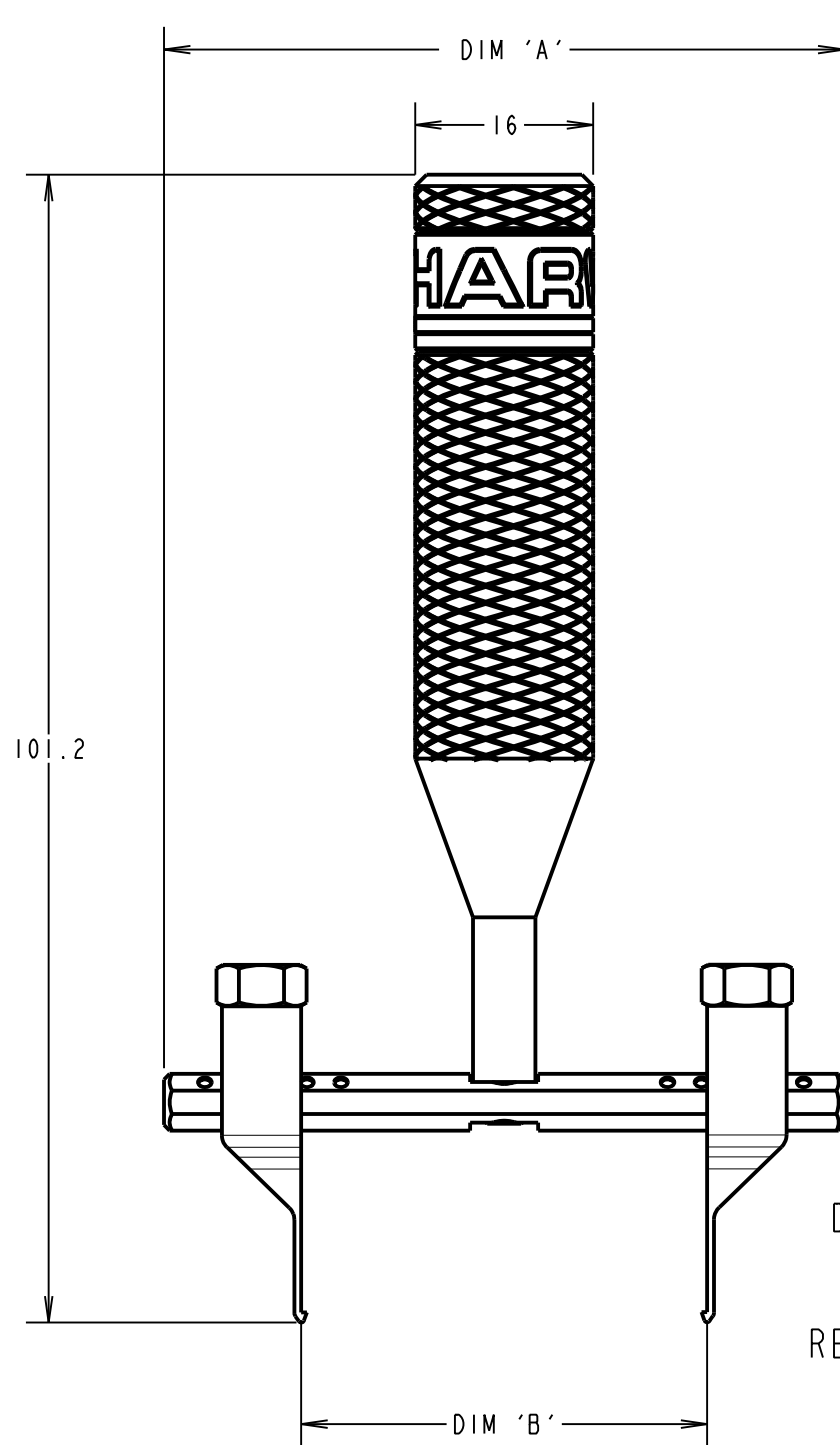

SUPPLIED AS A KIT IN A CASE,  
DE-LATCHING TOOL SHOWN ASSEMBLED  
FOR ILLUSTRATION PURPOSES ONLY

REFER TO TOOLING INSTRUCTION SHEET  
IS-30 PRIOR TO USE.

DIM 'A'	DIM 'B'
60.0	21.80, 27.80, 35.80, 45.80
34.0	7.80, 11.80, 15.80, 19.80
32.0	5.80, 9.80, 13.80, 17.80

- NOTES:
1. INSTRUCTION SHEETS ARE AVAILABLE FOR THIS TOOL. REFER TO TOOLING INSTRUCTION SHEET IS-30 FOR MORE INFORMATION.
  2. ANY PARTS REQUIRED TO BE SCREWED TOGETHER, MUST ONLY BE HAND TIGHTENED.
  3. HANDLE WITH CARE. WHEN NOT IN USE STORE ADJUSTABLE JAWS IN HANDLE OR CASE.
  4. FOR REPLACEMENT PARTS REFER TO TOOLING INSTRUCTION SHEET IS-30 FOR FURTHER DETAILS AND PART NUMBERS.

FM	6	22.01.18	20954
NAME	ISS.	DATE	C/NOTE
APPROVED: F. MCGOWAN			
CHECKED: M. PLESTED			
DRAWN: S.FLOWER			
CUSTOMER REF.:			
ASSEMBLY DRG:			

 www.harwin.com technical@harwin.com	THIS DRAWING AND ANY INFORMATION OR DESCRIPTIVE MATTER SET OUT HEREON ARE CONFIDENTIAL AND COPYRIGHT PROPERTY OF THE HARWIN GROUP AND MUST NOT BE DISCLOSED, LOANED, COPIED OR USED FOR MANUFACTURING, TENDERING OR FOR ANY OTHER PURPOSE WITHOUT THEIR WRITTEN PERMISSION.	TOLERANCES X. = ±1mm X.X = ±0.50mm X.XX = ±0.10mm X.XXX = ±0.01mm ANGLES = ±5° UNLESS STATED	MATERIAL: METAL TOOL	TITLE: DATAMATE L-TEK DE-LATCHING TOOL WITH STORAGE CASE
			FINISH: CLEAN S/AREA: mm <sup>2</sup>	DRAWING NUMBER: <b>Z80-299</b>