

**SURFACE MOUNT GENERAL PURPOSE SILICON RECTIFIERS***Forward Current-3.0A**Reverse Voltage-50V to 1000V***FEATURES**

- ◆ For surface mount applications
- ◆ Glass passivated chip junction
- ◆ Low profile package
- ◆ Easy to pick and place
- ◆ Lead free in comply with EU RoHS2011/65/EU directives

**MECHANICAL DATA**

- ◆ Case: SMC molded plastic body
- ◆ Terminals: Solderable per MIL-STD-750 , Method 2026
- ◆ Weight: Approximated 0.22 grams

**PINNING**

PIN	DESCRIPTION
1	Cathode
2	Anode

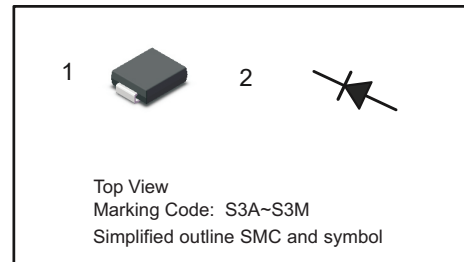
**MAXIMUM RATINGS AND ELECTRICAL CHARACTERISTICS**

Ratings at 25°C ambient temperature unless otherwise specified.

Single phase half-wave 60 Hz, resistive or inductive load, for capacitive load current derating by 20 %.

PARAMETER	SYMBOL	S3AC!D>	S3BC!D>	S3DC!D>	S3GC!D>	S3JC!D>	S3KC!D>	S3MC!D>	UNIT
Maximum Repetitive Peak Reverse Voltage	$V_{RRM}$	50	100	200	400	600	800	1000	V
Maximum RMS Voltage	$V_{RMS}$	35	70	140	280	420	560	700	V
Maximum DC Blocking Voltage	$V_{DC}$	50	100	200	400	600	800	1000	V
Maximum Average Forward Rectified Current at $T_C=125^\circ\text{C}$	$I_{F(AV)}$	3.0							A
Peak Forward Surge Current (Note1)	$I_{FSM}$	90							A
Maximum Forward Voltage at 3.0 A	$V_F$	1.0							V
Maximum DC Reverse Current at Rated DC Blocking Voltage at $T_A=25^\circ\text{C}$ $T_A=125^\circ\text{C}$	$I_R$	5 150							uA
Typical Junction Capacitance (Note2)	$C_J$	40							pF
Typical Thermal Resistance (Note3)	$R_{\theta JA}$ $R_{\theta JC}$	40 16							$^\circ\text{C/W}$
Operating and Storage Temperature Range	$T_J, T_{STG}$	-55 to +150							$^\circ\text{C}$

Notes: 1. Measured at 8.3 ms single half sine wave superimposed on rated load (JEDEC Method).

2. Measured at 1MHz and applied reverse voltage of 4 V D.C.

3. P.C.B. mounted with 2.0" X 2.0" (5 X 5 cm) copper pad areas.



RATINGS AND CHARACTERISTIC CURVES

Fig.1 Forward Current Derating Curve

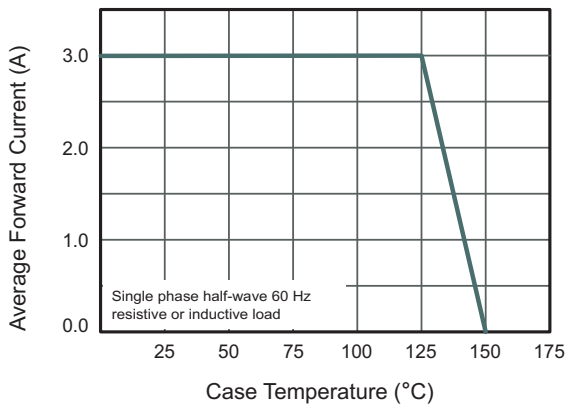

Fig.2 Typical Reverse Characteristics

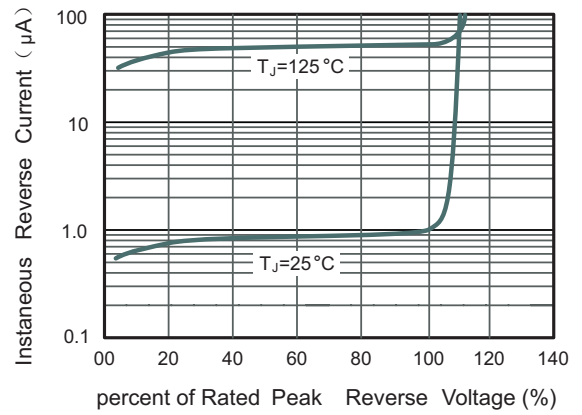

Fig.3 Typical Forward Characteristic

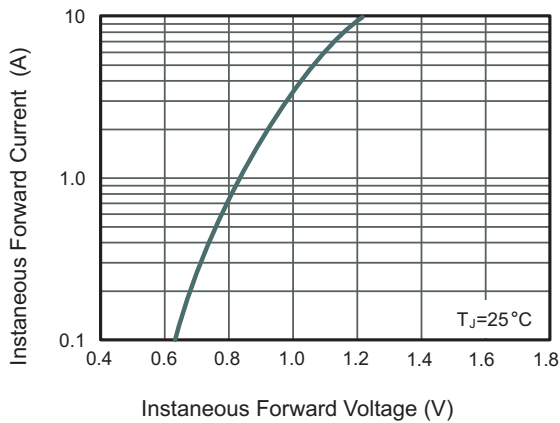

Fig.4 Typical Junction Capacitance

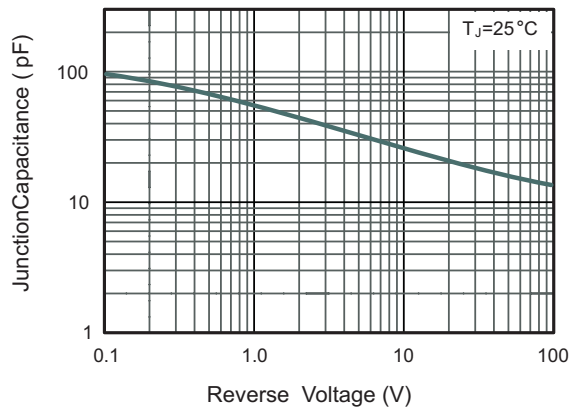
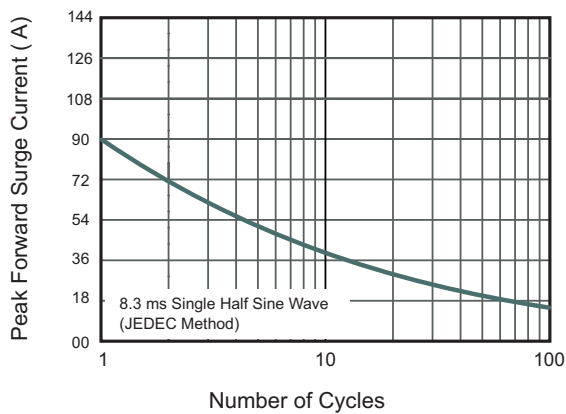

Fig.6 Maximum Non-Repetitive Peak Forward Surge Current





PACKAGE OUTLINE

SMC

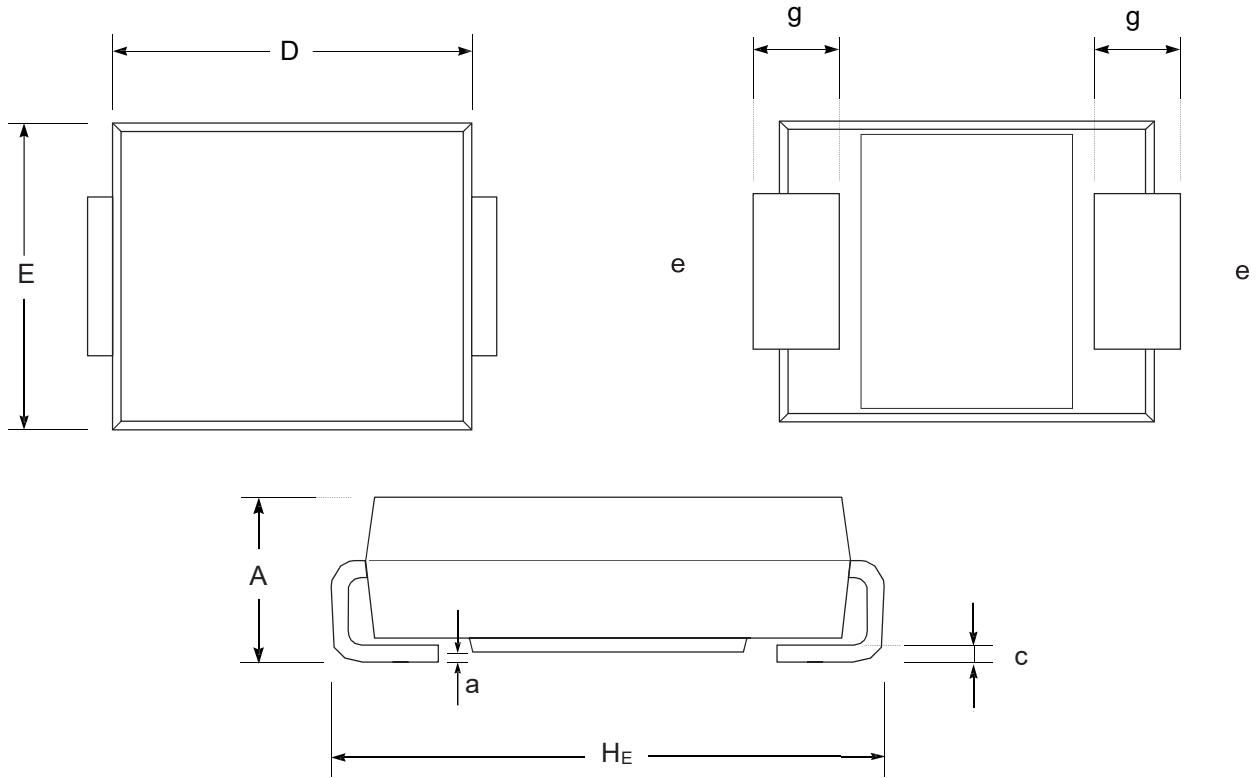

UNIT		A	D	E	HE	a	c	e	g
mm	max	2.5	7.0	6.0	8.1	0.21	0.35	3.1	1.5
	min	2.1	6.7	5.7	7.7	0.05	0.25	2.9	0.9
mil	max	98	276	236	319	8.3	14	122	59
	min	82	264	224	303	2.0	10	114	35

ORDERING INFORMATION

Device	Package	Shipping
S3AC-PJ thru S3MC-PJ	SMC	3,000/ Tape & Reel (13 inches)