

$I_{PN} = 50A$

Features

- ◆ Hall effect measuring principle
- ◆ Galvanic isolation between primary and secondary circuit
- ◆ Low power consumption
- ◆ Extended measuring range
- ◆ Insulated plastic case recognized according to UL 94-V0

Advantages

- ◆ Very good linearity
- ◆ Excellent accuracy
- ◆ Low temperature drift
- ◆ Wide frequency bandwidth
- ◆ Optimized response time
- ◆ No insertion losses
- ◆ High immunity against external Interference
- ◆ Excellent performance and price

Industrial applications

- ◆ AC variable speed drives
- ◆ Battery supplied applications
- ◆ Uninterruptible Power Supplies (UPS)
- ◆ Power supplies for welding applications
- ◆ Static converters for DC motor drives
- ◆ Switched-Mode Power Supplies (SMPS)

TYPES OF PRODUCTS			
Type	Primary nominal current r. m. s I_{PN} (A)	Primary current measuring range I_P (A)	Measuring resistance (@70°C) R_M (Ω)
SICDS100V6	100 ⁽¹⁾	0~±110	0~50 with±12V@±100Amax
			0 ~ 22 with±12V@±120Amax
			0~110 with±15V@±100Amax
			0 ~ 33 with±15V@±120Amax

General Description

For the electronic measurement of currents: DC, AC, pulsed, mixed, with a galvanic isolation between the primary circuit (high power) and the secondary circuit (electronic circuit)

Parameters Table

PARAMETERS	SYMBOL	UNIT	VALUE	CONDITIONS	
Electrical data					
Supply voltage($\pm 5\%$)	V_C	V	$\pm 12 \dots 15$		
Current consumption	I_C	mA	$10(@\pm 15)+I_s$		
Secondary nominal r.m.s. current	I_{SN}	mA	50	@ I_{PN}	
Conversion ratio	K_N		1:2000		
Accuracy - Dynamic performance data					
Linearity	ϵ_L	%	$< \pm 0.15$		
Accuracy	X_G	%	$< \pm 0.45$	@ I_{PN} , $V_C = \pm 15V$, $T_A = 25^\circ C$	
			$< \pm 0.70$	@ I_{PN} , $V_C = \pm 12 \dots 15V$, $T_A = 25^\circ C$	
Offset current	I_O	mA	$< \pm 0.10$	@ $I_p = 0, T_A = 25^\circ C$	
Thermal drift of I_o	I_{OT}	mA	Typ	Max	
			± 0.05	± 0.30	@ $I_p = 0, -25^\circ C \sim +85^\circ C$
			± 0.10	± 0.50	@ $I_p = 0, -40^\circ C \sim -25^\circ C$
Response time	t_r	μS	< 1	@ 90% of I_{PN} step	
di/dt accurately followed	d _i /dt	A/ μS	> 200		
Frequency bandwidth (1)	BW	kHz	DC~200	@ -1dB	
General data					
Ambient operating temperature	T_A	$^\circ C$	-40 ~ +85		
Ambient storage temperature	T_S	$^\circ C$	-40 ~ +90		
Secondary coil resistance	R_s	Ω	120	@ $T_A = 70^\circ C$	
Isolation characteristics					
R. m. s voltage for AC isolation test	V_d	KV	2.5	@ 50Hz, 1 min	
Impulse withstand voltage 1.2/50us	V_w	KV	4.5		
Creepage distance	dCp	mm	5		
Clearance distance	dCI	mm	5		
Comparative Tracking Index	CTI		175	Group IIIa	

Notes:

- 1) DC can be measured 100A, and AC for 80A.
- 2) Please refer to derating curves in the technical file to avoid excessive core heating at high frequency.

Dimensions SICDS100V6 (in mm. 1 mm = 0.0394 inch)

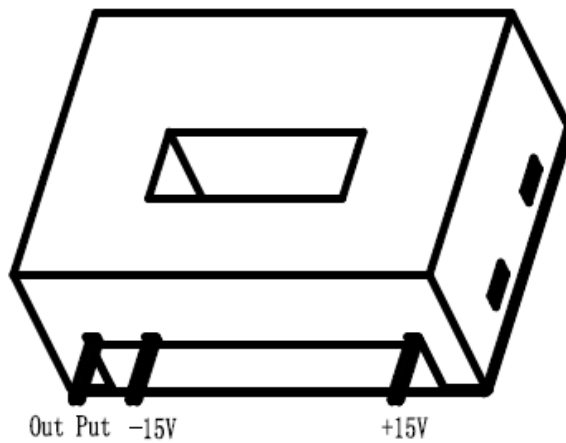
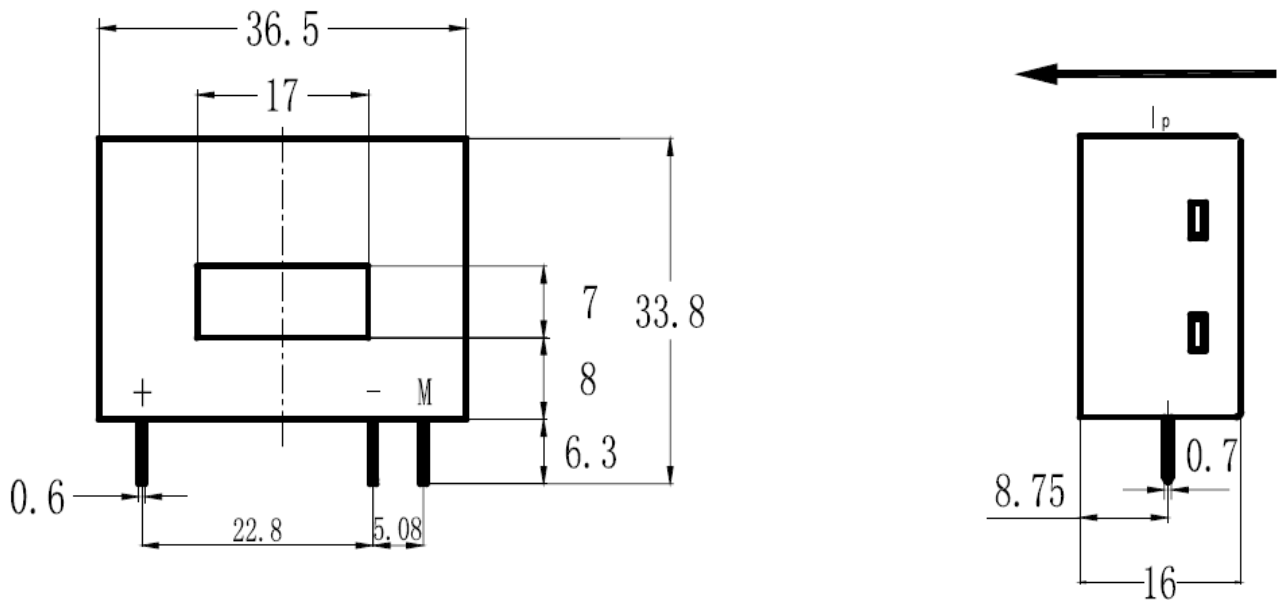

Instructions of use

- 1 When the test current passes through the sensor, you can get the size of the output current. (Warning: wrong connection may lead to sensors damage.)
- 2 I_s is positive when I_p flows in the direction of the arrow.
- 3 In order to achieve the best magnetic coupling, the primary windings have to be wound over the top edge of the device.
- 4 According to user needs, different rated input currents and output currents of the sensors can be customized.

RESTRICTIONS ON PRODUCT USE

The information contained herein is subject to change without notice.

SEC ELECTRONICS INC. (for short SEC) exerts the greatest possible effort to ensure high quality and reliability. Nevertheless, semiconductor devices in general can malfunction or fail due to their inherent electrical sensitivity and vulnerability to physical stress. It is the responsibility of the buyer, when utilizing SEC products, to comply with the standards of safety in making a safe design for the entire system, including redundancy, fire-prevention measures, and malfunction prevention, to prevent any accidents, fires, or community damage that may ensue. In developing your designs, please ensure that SEC products are used within specified operating ranges as set forth in the most recent SEC products specifications.

The SEC products listed in this document are intended for usage in general electronics applications (computer, personal equipment, office equipment, measuring equipment, industrial robotics, domestic appliances, etc.). These SEC products are neither intended nor warranted for usage in equipment that requires extraordinarily high quality and/or reliability or a malfunction or failure of which may cause loss of human life or bodily injury (“Unintended Usage”). Unintended Usage include atomic energy control instruments, airplane or spaceship instruments, transportation instruments, traffic signal instruments, combustion control instruments, medical instruments, all types of safety devices, etc.. Unintended Usage of SEC products listed in this document shall be made at the customer’s own risk.