

FSUSB31

Low-Power, Single-Port, High-Speed USB 2.0 (480Mbps) Switch

Features

- Low On Capacitance: 3.7pF (Typical)
- Low On Resistance: 6.5Ω (Typical)
- Low Power Consumption: 1μA (Maximum)
 - 10μA Maximum I_{CCCT} Over an Expanded Control Voltage Range: $V_{IN} = 2.6V$, $V_{CC} = 4.3V$
- Wide -3dB Bandwidth: > 720MHz
- 8kV I/O to GND ESD Protection
- Power-off Protection When $V_{CC} = 0V$, D+ / D- Pins Can Tolerate up to 5.5V
- Packaged in:
 - 8-lead MicroPak™ (1.6 x 1.6mm)
 - 8-lead US8
 - 8-lead Ultrathin MLP (1.2 x 1.4mm)

Applications

- Cell Phone, PDA, Digital Camera, and Notebook
- LCD Monitor, TV, and Set-top Box

Related Resources

- [AN-6022 Using the FSUSB30/31 to Comply with USB 2.0 Fault Condition Requirements](#)

Description

The FSUSB31 is a low-power, single-port, high-speed USB 2.0 switch. This part is configured as a double-pole, single-throw switch and is optimized for switching or isolating a high-speed (480Mbps) source or a high-speed and full-speed (12Mbps) source. The FSUSB31 is compatible with the requirements of USB2.0 and features an extremely low on capacitance (C_{ON}) of 3.7pF. The wide bandwidth of this device (>720MHz) exceeds the bandwidth needed to pass the third harmonic, resulting in signals with minimum edge and phase distortion. Superior channel-to-channel crosstalk minimizes interference.

The FSUSB31 contains special circuitry on the D+ / D- pins that allows the device to withstand an over-voltage condition. This device is also designed to minimize current consumption even when the control voltage applied to the OE pin is lower than the supply voltage (V_{CC}). This feature is especially valuable for mobile applications, such as cell phones, allowing direct interface with the general-purpose I/Os of the baseband processor. Other applications include port isolation and switching in portable cell phones, PDAs, digital cameras, printers, and notebook computers.

Ordering Information

Part Number	Package	 Eco Status	Package Description
FSUSB31K8X	MAB08A	Green	8-Lead US8, JEDEC MO-187, Variation CA 3.1mm Wide
FSUSB31L8X	MAC08A	RoHS	8-Lead MicroPak, 1.6mm Wide
FSUSB31UMX	UMLP08A	Green	8-Lead, Ultrathin Molded Leadless Package (UMLP), 1.2 x 1.4mm

 For Fairchild's definition of "green" Eco Status, please visit: http://www.fairchildsemi.com/company/green/rohs_green.html.

Application Diagram

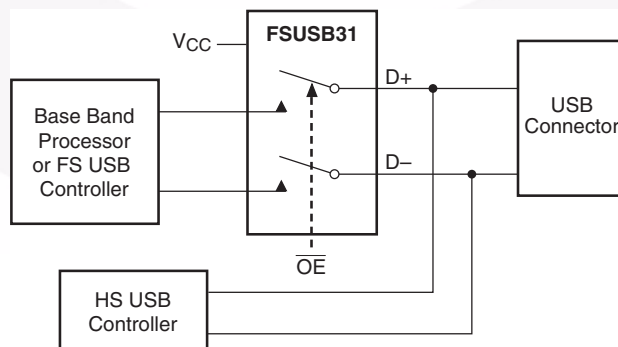

Figure 1. Typical Application Diagram

MicroPak™ is a trademark of Fairchild Semiconductor Corporation.

Analog Symbol

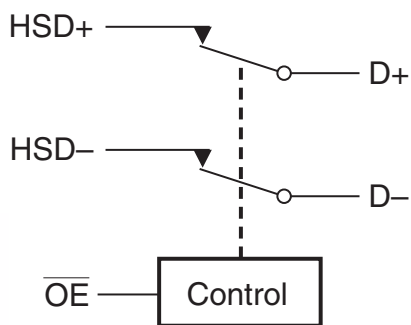

Figure 2. Analog Symbol

Pin Descriptions

Pin Name	Description
\overline{OE}	Bus Switch Enable
D+, D-, HSD+, HSD-	Data Ports
NC	No Connect

Truth Table

\overline{OE}	Function
HIGH	Disconnect
LOW	D+, D- = HSD+, HSD-

Connection Diagrams

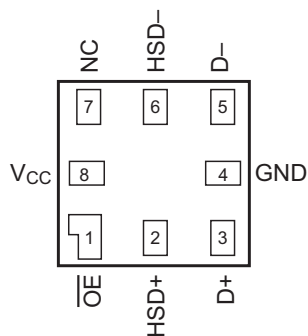

Figure 3. Pin Assignments for MicroPak

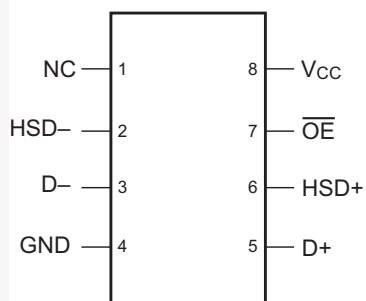

Figure 4. Pin Assignments for US8

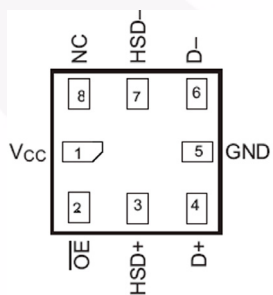

Figure 5. Pin Assignments for UMLP

Absolute Maximum Ratings

Stresses exceeding the absolute maximum ratings may damage the device. The device may not function or be operable above the recommended operating conditions and stressing the parts to these levels is not recommended. In addition, extended exposure to stresses above the recommended operating conditions may affect device reliability. The absolute maximum ratings are stress ratings only.

Symbol	Parameter		Minimum	Maximum	Unit
V_{CC}	Supply Voltage		-0.5	5.5	V
V_S	DC Input Voltage ⁽¹⁾		-0.5	V_{CC}	V
V_{IN}	DC Switch Voltage ⁽¹⁾	HSD	-0.5	V_{CC}	V
		D+, D-	-0.5	V_{CC}	V
I_{IK}	DC Input Diode Current		-50		mA
I_{OUT}	DC Output Current			50	mA
T_{STG}	Storage Temperature		-65	+150	°C
ESD	Human Body Model: JESD22-A114	All Pins		7.5	kV
		I/O to GND		8	kV

Note:

1. The input and output negative voltage ratings may be exceeded if the input and output diode current ratings are observed.

Recommended Operating Conditions

The Recommended Operating Conditions table defines the conditions for actual device operation. Recommended operating conditions are specified to ensure optimal performance to the datasheet specifications. Fairchild does not recommend exceeding them or designing to absolute maximum ratings.

Symbol	Parameter	Minimum	Maximum	Unit
V_{CC}	Supply Voltage	3.0	4.3	V
V_{IN}	Control Input Voltage ⁽²⁾	0	V_{CC}	V
	Switch Input Voltage	0	V_{CC}	V
T_A	Operating Temperature	-40	+85	°C

Note:

2. Control input must be held HIGH or LOW and it must not float.

DC Electrical Characteristics

All typical values are at 25°C unless otherwise specified.

Symbol	Parameter	Conditions	V _{CC} (V)	T _A = -40°C to +85°C			Unit
				Min.	Typ.	Max.	
V _{IK}	Clamp Diode Voltage	I _{IN} = -18mA	3.0			-1.2	V
V _{IH}	Input Voltage HIGH		3.0 to 3.6	1.3			V
			4.3	1.7			
V _{IL}	Input Voltage LOW		3.0 to 3.6			0.5	V
			4.3			0.7	
I _{IN}	Control Input Leakage	V _{IN} = 0V to V _{CC}	4.3	-1.0		1.0	μA
I _{OZ}	OFF State Leakage	0 ≤ HSD ≤ V _{CC}	4.3	-2.0		2.0	μA
I _{OFF}	Power OFF Leakage Current (D+, D-)	V _{IN} = 0.0V to 4.3V, V _{CC} = 0V	0	-2.0		2.0	μA
R _{ON}	Switch On Resistance ⁽³⁾	V _{IN} = 0.4V, I _{ON} = -8mA	3.0		6.5	10.0	Ω
ΔR _{ON}	Delta R _{ON} ⁽⁴⁾	V _{IN} = 0.4V, I _{ON} = -8mA	3.0		0.35		Ω
R _{ON} Flatness	R _{ON} Flatness ⁽³⁾	V _{IN} = 0.0V - 1.0V, I _{ON} = -8mA	3.0		2.0		Ω
I _{CC}	Quiescent Supply Current	V _{IN} = 0.0V or V _{CC} , I _{OUT} = 0	4.3			1.0	μA
I _{CCT}	Increase in I _{CC} Current per Control Voltage and V _{CC} Levels	V _{IN} = 2.6V, V _{CC} = 4.3V	4.3			10.0	μA

Notes:

3. Measured by the voltage drop between Dn, HSD, and Dn pins at the indicated current through the switch. On resistance is determined by the lower of the voltage on the two ports.
4. Guaranteed by characterization.

AC Electrical Characteristics

All typical values are for V_{CC} = 3.3V are at 25°C unless otherwise specified.

Symbol	Parameter	Conditions	V _{CC} (V)	T _A = -40°C to +85°C			Unit	Figure Number
				Min.	Typ.	Max.		
t _{ON}	Turn-On Time, OE to Output	V _{IN} = 0.8V, R _L = 50Ω, C _L = 5pF	3.0 to 3.6		15.0	30.0	ns	Figure 13
t _{OFF}	Turn-Off Time, OE to Output	V _{IN} = 0.8V, R _L = 50Ω, C _L = 5pF	3.0 to 3.6		12.0	25.0	ns	Figure 13
t _{PD}	Propagation Delay ⁽⁵⁾	R _L = 50Ω, C _L = 5pF	3.3		0.25		ns	Figure 11 Figure 12
t _{BBM}	Break-Before-Make	R _L = 50Ω, C _L = 5pF, V _{IN} = 0.8V	3.0 to 3.6	2.0		6.5	ns	Figure 14
O _{IRR}	Off Isolation (Non-Adjacent)	R _T = 50Ω, f = 240MHz	3.0 to 3.6		-35.0		dB	Figure 17
Xtalk	Non-Adjacent Channel Crosstalk	R _T = 50Ω, f = 240MHz	3.0 to 3.6		-55.0		dB	Figure 18
BW	-3dB Bandwidth	R _T = 50Ω, C _L = 0pF	3.0 to 3.6		720		MHz	Figure 16
		R _T = 50Ω, C _L = 5pF			550			

Note:

5. Guaranteed by characterization.

USB Hi-Speed Related AC Electrical Characteristics

Symbol	Parameter	Conditions	V _{CC} (V)	T _A = -40°C to +85°C			Unit	Figure Number
				Min.	Typ.	Max.		
t _{SK(O)}	Channel-to-Channel Skew ⁽⁶⁾	C _L = 5pF	3.0 to 3.6		50.0		ps	Figure 11 Figure 15
t _{SK(P)}	Skew of Opposite Transitions of the Same Output ⁽⁶⁾	C _L = 5pF	3.0 to 3.6		20.0		ps	Figure 11 Figure 15
t _J	Total Jitter ⁽⁶⁾	R _L = 50Ω, C _L = 5pF, t _R = t _F = 500ps at 480 Mbps (PRBS = 2 ¹⁵ - 1)	3.0 to 3.6		200		ps	

Note:

6. Guaranteed by design.

Capacitance

Symbol	Parameter	Conditions	T _A = -40°C to +85°C			Unit	Figure Number
			Min.	Typ.	Max.		
C _{IN}	Control Pin Input Capacitance	V _{CC} = 0V		1.0		pF	Figure 20
C _{ON}	On Capacitance	V _{CC} = 3.3V, \overline{OE} = 0V		3.7		pF	Figure 19
C _{OFF}	Off Capacitance	V _{CC} and \overline{OE} = 3.3V		1.7		pF	Figure 20

Typical Characteristics

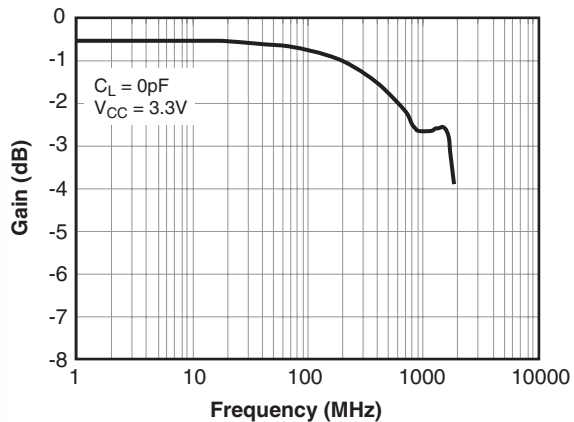

Figure 6. Gain vs. Frequency

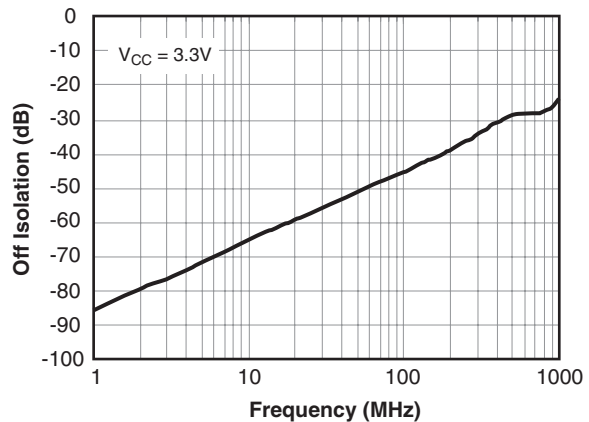

Figure 7. Off Isolation

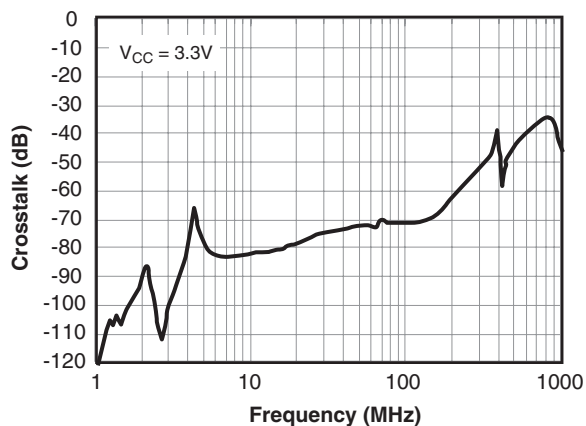

Figure 8. Crosstalk



Test Diagrams

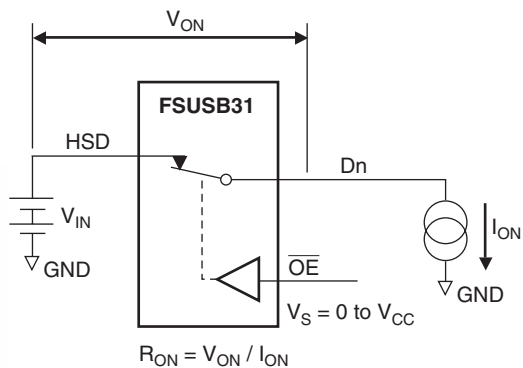
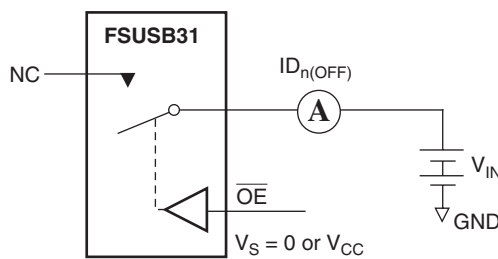
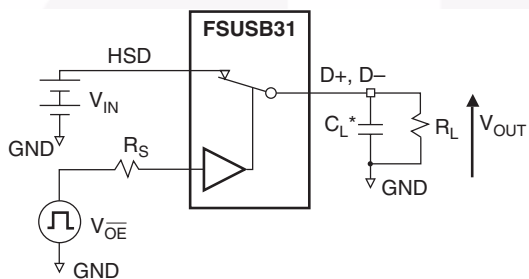

Figure 9. On Resistance



Each switch port is tested separately.

Figure 10. Off Leakage



R_L , R_S , and C_L are functions of the application environment (see AC Electrical tables for specific values).

* C_L includes test fixture and stray capacitance.

Figure 11. AC Test Circuit Load

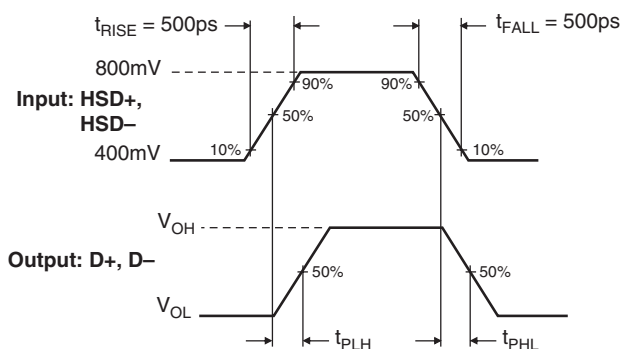

Figure 12. Switch Propagation Delay Waveforms (t_{PD})

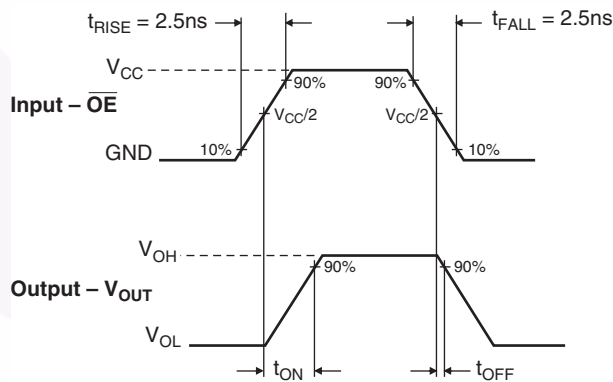
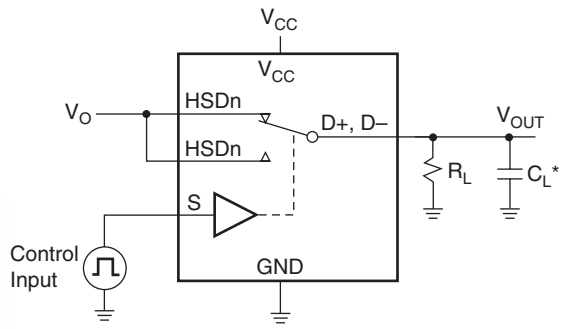

Figure 13. Turn On / Turn Off Waveform (t_{ON} / t_{OFF})

Test Diagrams (Continued)



*C_L includes test fixture and stray capacitance.

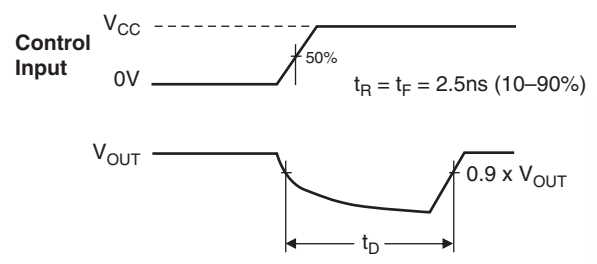

Figure 14. Break-Before-Make (t_{BBM})

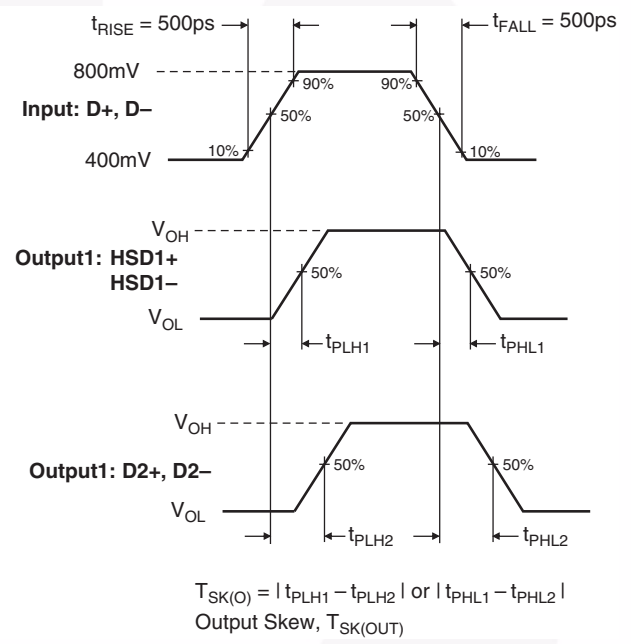
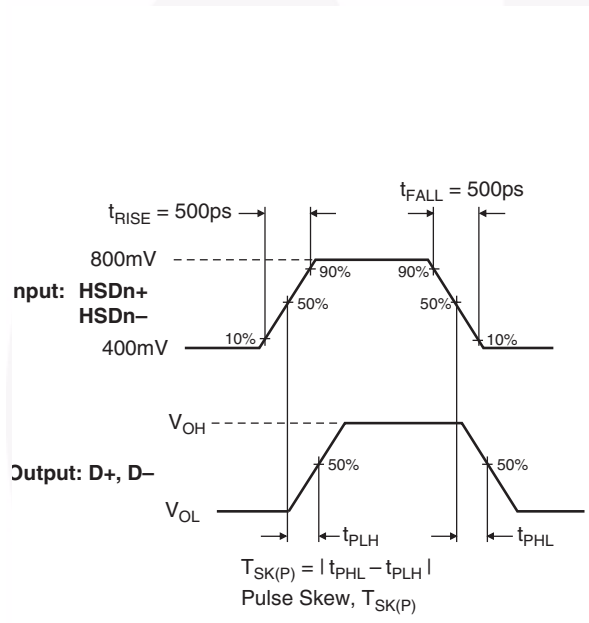
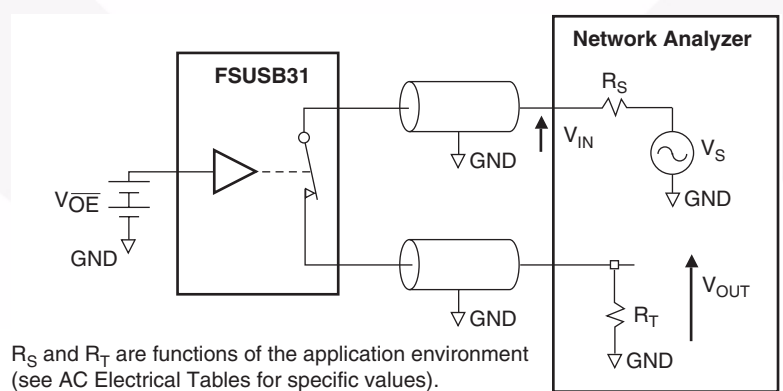

Figure 15. Switch Skew Tests



R_S and R_T are functions of the application environment (see AC Electrical Tables for specific values).

Figure 16. Bandwidth

Test Diagrams (Continued)

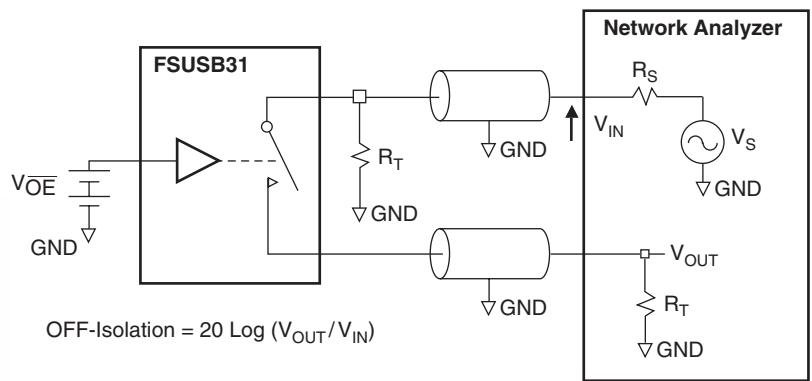

Figure 17. Channel Off Isolation

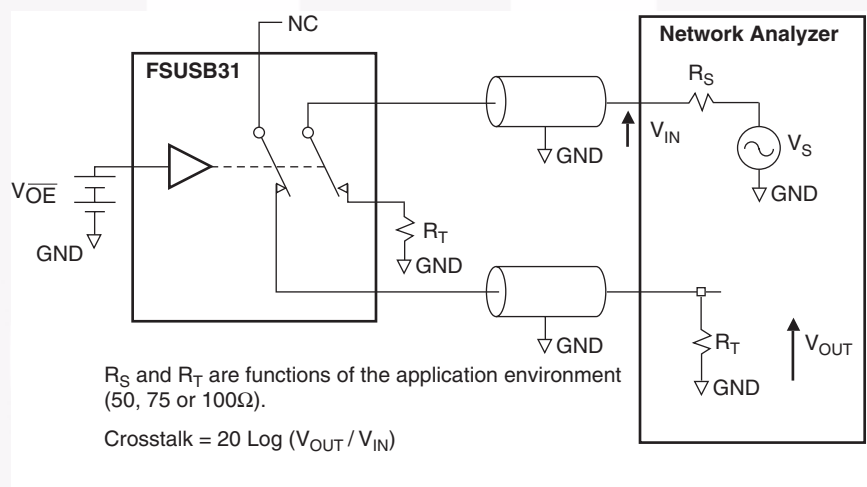

Figure 18. Non-Adjacent Channel-to-Channel Crosstalk

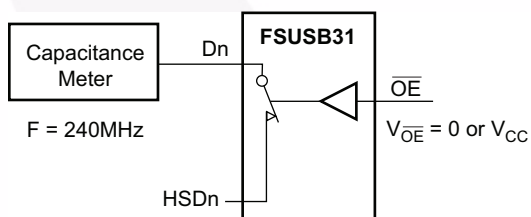

Figure 19. Channel On Capacitance

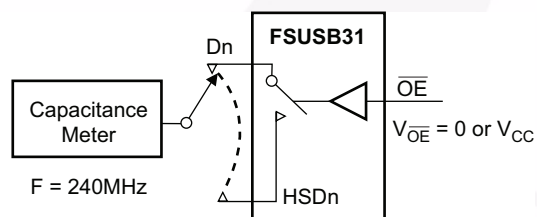

Figure 20. Channel Off Capacitance

Application Guidance: Meeting USB 2.0 Vbus Short Requirements

In section 7.1.1 of the USB 2.0 specification, it notes that USB devices must be able to withstand a Vbus short to D+ or D- when the USB device is either powered off or powered on. The FSUSB31 can be successfully configured to meet both these requirements.

Power-Off Protection

For a Vbus short circuit, the switch is expected to withstand such a condition for at least 24 hours. The FSUSB31 has specially designed circuitry which prevents unintended signal bleed through as well as guaranteed system reliability during a power-down, over-voltage condition. The protection has been added to the common pins (D+, D-).

Power-On Protection

The USB 2.0 specification also notes that the USB device should be capable of withstanding a Vbus short during transmission of data. Fairchild recommends adding a 100Ω series resistor between the switch VCC pin and supply rail to protect against this case. This modification works by limiting current flow back into the VCC rail during the over-voltage event so current remains within the safe operating range. In this application, the switch passes the full 5.25V input signal through to the selected output, while maintaining specified off isolation on the un-selected pins.

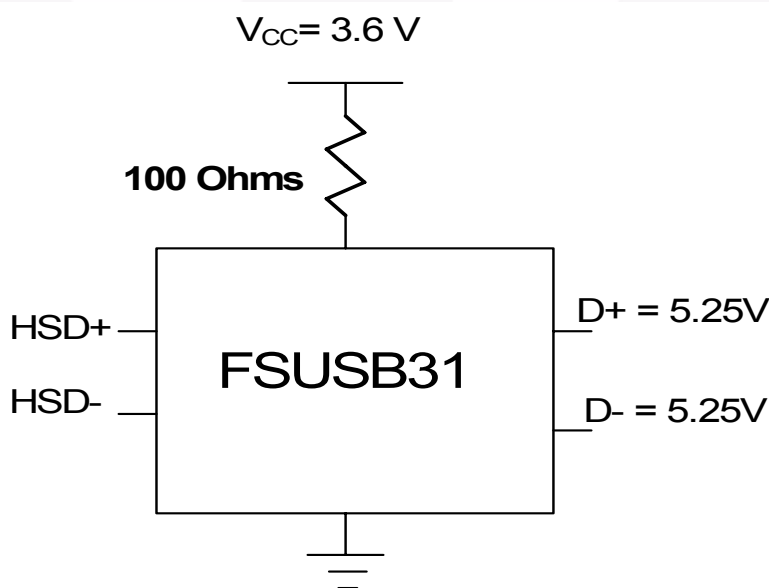
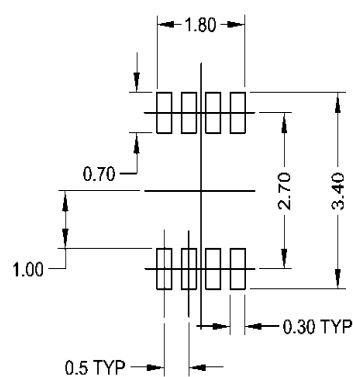
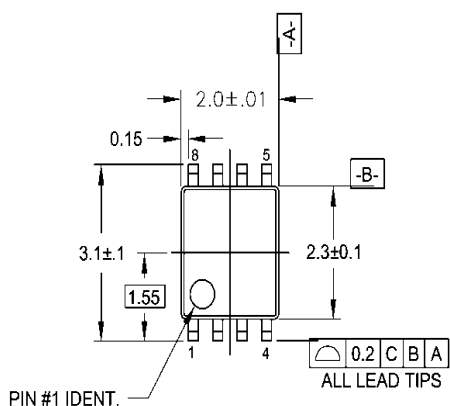

Figure 21. A 100Ω resistor in series with the V_{CC} supply allows the FSUSB31 to withstand a Vbus short when powered up

For more information, see Applications Note AN-6022 — Using the FSUSB30/FSUSB31 to Comply with USB 2.0 Fault Condition Requirements at www.fairchildsemi.com.

Physical Dimensions



LAND PATTERN RECOMMENDATION

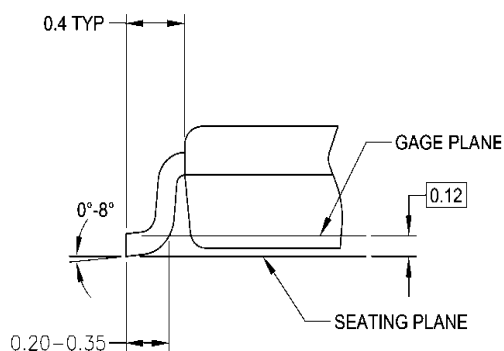
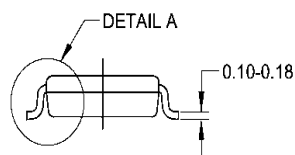
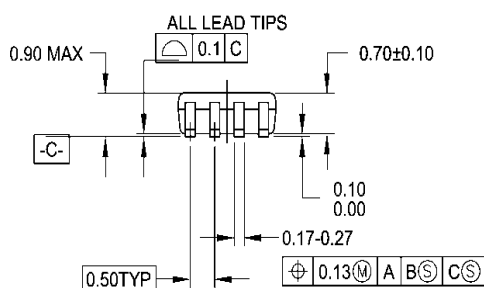

DETAIL A

NOTES:

- A. CONFORMS TO JEDEC REGISTRATION MO-187
- B. DIMENSIONS ARE IN MILLIMETERS.
- C. DIMENSIONS ARE EXCLUSIVE OF BURRS, MOLD FLASH, AND TIE BAR EXTRUSIONS.
- D. DIMENSIONS AND TOLERANCES PER ANSI Y14.5M, 1982.

MAB08AREVC

Figure 22. 8-Lead US8, JEDEC MO-187, Variation CA 3.1mm Wide

For MicroPak™ tape and reel specifications, please visit Fairchild's website: <http://www.fairchildsemi.com/ms/MS/MS-522.pdf>.

Package drawings are provided as a service to customers considering Fairchild components. Drawings may change in any manner without notice. Please note the revision and/or date on the drawing and contact a Fairchild Semiconductor representative to verify or obtain the most recent revision. Package specifications do not expand the terms of Fairchild's worldwide terms and conditions, specifically the warranty therein, which covers Fairchild products.

Always visit Fairchild Semiconductor's online packaging area for the most recent package drawings:

<http://www.fairchildsemi.com/packaging/>.

Physical Dimensions (Continued)

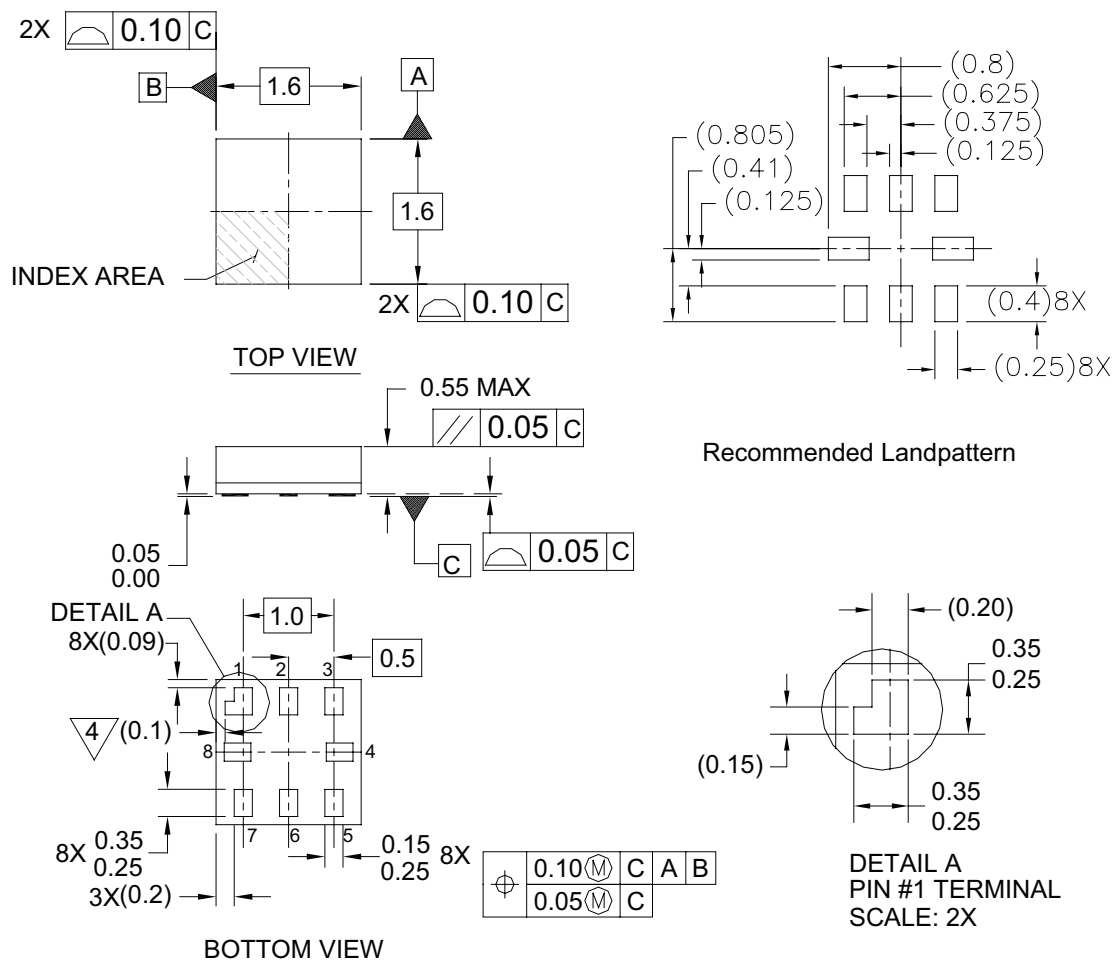

Notes:

1. PACKAGE CONFORMS TO JEDEC MO-255 VARIATION UAAD
2. DIMENSIONS ARE IN MILLIMETERS
3. DRAWING CONFORMS TO ASME Y.14M-1994
4. PIN 1 FLAG, END OF PACKAGE OFFSET
5. DRAWING FILE NAME: MKT-MAC08AREV4

MAC08AREV4

Figure 23. 8-Lead MicroPak, 1.6mm Wide

For MicroPak™ tape and reel specifications, please visit Fairchild's website:
http://www.fairchildsemi.com/products/logic/pdf/micropak_tr.pdf

Package drawings are provided as a service to customers considering Fairchild components. Drawings may change in any manner without notice. Please note the revision and/or date on the drawing and contact a Fairchild Semiconductor representative to verify or obtain the most recent revision. Package specifications do not expand the terms of Fairchild's worldwide terms and conditions, specifically the warranty therein, which covers Fairchild products.

Always visit Fairchild Semiconductor's online packaging area for the most recent package drawings:
<http://www.fairchildsemi.com/packaging/>

Physical Dimensions (Continued)

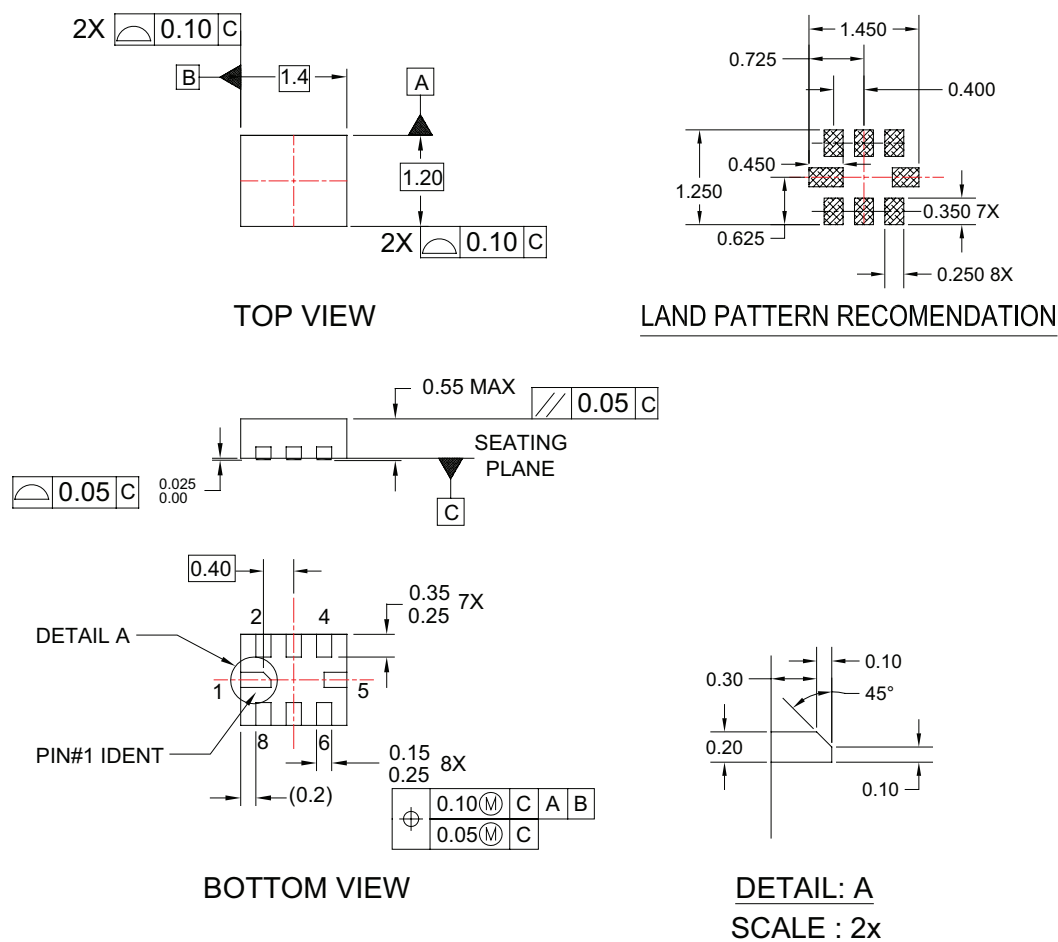

NOTES:

- A. DOES NOT CONFORMS TO JEDEC STANDARD.
- B. DIMENSIONS ARE IN MILLIMETERS.
- C. DIMENSIONS AND TOLERANCES CONFORMS TO ASME Y14.5M, 1994.
- D. DRAWING FILE NAME : UMLP08Arev1

Figure 24. 8-Lead, Ultrathin Molded Leadless Package (UMLP), 1.2 x 1.4mm

For MicroPak™ tape and reel specifications, please visit Fairchild's website:
http://www.fairchildsemi.com/products/logic/pdf/micropak_tr.pdf







Package drawings are provided as a service to customers considering Fairchild components. Drawings may change in any manner without notice. Please note the revision and/or date on the drawing and contact a Fairchild Semiconductor representative to verify or obtain the most recent revision. Package specifications do not expand the terms of Fairchild's worldwide terms and conditions, specifically the warranty therein, which covers Fairchild products.

Always visit Fairchild Semiconductor's online packaging area for the most recent package drawings:
<http://www.fairchildsemi.com/packaging/>



TRADEMARKS

The following includes registered and unregistered trademarks and service marks, owned by Fairchild Semiconductor and/or its global subsidiaries, and is not intended to be an exhaustive list of all such trademarks.

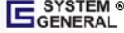
Build it Now™	F-PFS™	PowerTrench®	The Power Franchise®
CorePLUS™	FRFET®	Programmable Active Droop™	
CorePOWER™	Global Power Resource™	QFET®	TinyBoost™
CROSSVOLT™	Green FPST™	QS™	TinyBuck™
CTL™	Green FPST™ e-Series™	Quiet Series™	TinyLogic®
Current Transfer Logic™	GTO™	RapidConfigure™	TINYOPTO™
EcoSPARK®	IntelliMAX™		TinyPower™
EfficientMax™	ISOPLANAR™	Saving our world, 1mW/W/kW at a time™	TinyPWM™
EZSWITCH™ *	MegaBuck™	SmartMax™	TinyWire™
	MICROCOUPLER™	SMART START™	μSerDes™
	MicroFET™	SPM®	
Fairchild®	MicroPak™	STEALTH™	UHC®
Fairchild Semiconductor®	MillerDrive™	SuperFET™	Ultra FRFET™
FACT Quiet Series™	MotionMax™	SuperSOT™.3	UniFET™
FACT®	Motion-SPM™	SuperSOT™.6	VCXT™
FAST®	OPTOLOGIC®	SuperSOT™.8	VisualMax™
FastvCore™	OPTOPLANAR®	SupreMOS™	
FlashWriter® *		SyncFET™	
FPS™	PDP μPM™		
	Power-SPM™		

* EZSWITCH™ and FlashWriter® are trademarks of System General Corporation, used under license by Fairchild Semiconductor.

DISCLAIMER

FAIRCHILD SEMICONDUCTOR RESERVES THE RIGHT TO MAKE CHANGES WITHOUT FURTHER NOTICE TO ANY PRODUCTS HEREIN TO IMPROVE RELIABILITY, FUNCTION, OR DESIGN. FAIRCHILD DOES NOT ASSUME ANY LIABILITY ARISING OUT OF THE APPLICATION OR USE OF ANY PRODUCT OR CIRCUIT DESCRIBED HEREIN; NEITHER DOES IT CONVEY ANY LICENSE UNDER ITS PATENT RIGHTS, NOR THE RIGHTS OF OTHERS. THESE SPECIFICATIONS DO NOT EXPAND THE TERMS OF FAIRCHILD'S WORLDWIDE TERMS AND CONDITIONS, SPECIFICALLY THE WARRANTY THEREIN, WHICH COVERS THESE PRODUCTS.

LIFE SUPPORT POLICY

FAIRCHILD'S PRODUCTS ARE NOT AUTHORIZED FOR USE AS CRITICAL COMPONENTS IN LIFE SUPPORT DEVICES OR SYSTEMS WITHOUT THE EXPRESS WRITTEN APPROVAL OF FAIRCHILD SEMICONDUCTOR CORPORATION.

As used herein:

1. Life support devices or systems are devices or systems which, (a) are intended for surgical implant into the body or (b) support or sustain life, and (c) whose failure to perform when properly used in accordance with instructions for use provided in the labeling, can be reasonably expected to result in a significant injury of the user.
2. A critical component in any component of a life support, device, or system whose failure to perform can be reasonably expected to cause the failure of the life support device or system, or to affect its safety or effectiveness.

ANTI-COUNTERFEITING POLICY

Fairchild Semiconductor Corporation's Anti-Counterfeiting Policy. Fairchild's Anti-Counterfeiting Policy is also stated on our external website, www.fairchildsemi.com, under Sales Support.

Counterfeiting of semiconductor parts is a growing problem in the industry. All manufacturers of semiconductor products are experiencing counterfeiting of their parts. Customers who inadvertently purchase counterfeit parts experience many problems such as loss of brand reputation, substandard performance, failed applications, and increased cost of production and manufacturing delays. Fairchild is taking strong measures to protect ourselves and our customers from the proliferation of counterfeit parts. Fairchild strongly encourages customers to purchase Fairchild parts either directly from Fairchild or from Authorized Fairchild Distributors who are listed by country on our web page cited above. Products customers buy either from Fairchild directly or from Authorized Fairchild Distributors are genuine parts, have full traceability, meet Fairchild's quality standards for handling and storage and provide access to Fairchild's full range of up-to-date technical and product information. Fairchild and our Authorized Distributors will stand behind all warranties and will appropriately address any warranty issues that may arise. Fairchild will not provide any warranty coverage or other assistance for parts bought from Unauthorized Sources. Fairchild is committed to combat this global problem and encourage our customers to do their part in stopping this practice by buying direct or from authorized distributors.

PRODUCT STATUS DEFINITIONS

Definition of Terms

Datasheet Identification	Product Status	Definition
Advance Information	Formative / In Design	Datasheet contains the design specifications for product development. Specifications may change in any manner without notice.
Preliminary	First Production	Datasheet contains preliminary data; supplementary data will be published at a later date. Fairchild Semiconductor reserves the right to make changes at any time without notice to improve design.
No Identification Needed	Full Production	Datasheet contains final specifications. Fairchild Semiconductor reserves the right to make changes at any time without notice to improve the design.
Obsolete	Not In Production	Datasheet contains specifications on a product that is discontinued by Fairchild Semiconductor. The datasheet is for reference information only.

Rev. 136