

## Digital Panel Meters 47 Series

### DC INPUT DIGITAL PANEL METER

(4 ½ digit, LED display type)

#### Functions & Features

- 4 ½ digit DC input digital panel meter
- 1/8 DIN size
- Moving average function to suppress the display flickering
- Scaling, forced zero, low-end cutout
- Max. and Min. value display
- Safety terminal cover tethered to the device with a strap
- IP66 front panel
- Separable terminal block

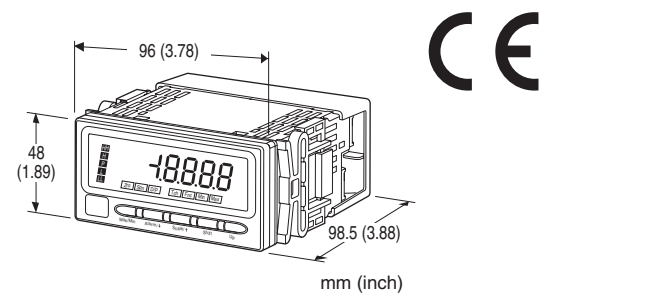

### MODEL: 47LV-[1][2][3][4]-[5][6]

#### ORDERING INFORMATION

- Code number: 47LV-1[1][2][3][4]-[5][6]
- Specify a code from below for each of [1] through [6].  
(e.g. 47LV-101G-M2/Q)
- Specify the specification for option code /Q  
(e.g. /C01/S01/SET)

#### [1] INPUT

- 1: ±10 V, ±5 V, 0 - 5 V, 1 - 5 V  
0 - 20 mA, 4 - 20 mA
- 2: ±1 V, ±100 mV, ±10 mV, ±1 mA
- 3: ±200 V, ±100 mA
- 4: ±100 µA (CE not available)
- 5: ±2 A, ±1 A (CE not available)
- 6: ±700 V (CE not available)

#### [2] DC OUTPUT

0: Without

##### Current

- A: 4 - 20 mA DC (Load resistance 550 Ω max.)
- D: 0 - 20 mA DC (Load resistance 550 Ω max.)

##### Voltage

- 3: 0 - 1 V DC (Load resistance 1000 Ω min.)  
(CE not available)

- 4: 0 - 10 V DC (Load resistance 10 kΩ min.)
- 5: 0 - 5 V DC (Load resistance 5000 Ω min.)
- 6: 1 - 5 V DC (Load resistance 5000 Ω min.)
- 4W: -10 - +10 V DC (Load resistance 10 kΩ min.)

#### [3] ALARM OUTPUT

- 0: None
- 1: N.O. relay contact, 4 points
- 2: SPDT relay contact, 2 points

#### [4] DISPLAY COLOR

- R: Red
- YR: Orange
- G: Green
- BG: Bluegreen
- B: Blue
- W: White

#### [5] POWER INPUT

##### AC Power

M2: 100 - 240 V AC (Operational voltage range 85 - 264 V, 50/60 Hz)

##### DC Power

- R: 24 V DC  
(Operational voltage range 24 V ±10 %, ripple 10 %p-p max.)
- P: 110 V DC  
(Operational voltage range 85 - 150 V, ripple 10 %p-p max.)

#### [6] OPTIONS

- blank: none
- /Q: With options (specify the specification)

#### SPECIFICATIONS OF OPTION: Q (multiple selections)

##### COATING (For the detail, refer to M-System's web site.)

Moving parts and indicators are not coated.

- /C01: Silicone coating
- /C02: Polyurethane coating
- /C03: Rubber coating

##### TERMINAL SCREW MATERIAL

/S01: Stainless steel

##### EX-FACTORY SETTING

/SET: Preset according to the Ordering Information Sheet  
(No. ESU-9502)

#### GENERAL SPECIFICATIONS

**Construction:** Panel flush mounting

**Degree of protection:** IP66; applicable to the front of the panel meter mounted according to the specified panel cutout

**Connection:** M3 separable screw terminal (torque 0.6 N·m)

**Screw terminal:** Nickel-plated steel (standard) or stainless

steel

**Housing material:** Flame-resistant resin (gray)

**Isolation:** Input to DC output to HH output or H output to L output or LL output to power

**Setting:** (Front button)

- Scaled range
- Input type
- Alarm setpoint
- Hysteresis (deadband)
- Moving average
- Others

(Refer to the instruction manual for details)

**Read rate:** 40 times/sec. (25 msec.)

**Averaging:** None or moving average

**Lockout setting:** Prohibiting certain operations; protecting settings

## DISPLAY

**Display:** 16 mm (.63) high, 4 ½ digits, 7-segment LED

**Display range:** -19999 to 19999

**Decimal point position:** 10<sup>-1</sup>, 10<sup>-2</sup>, 10<sup>-3</sup>, 10<sup>-4</sup> or none

**Zero indication:** Higher-digit zeros are suppressed.

**Over-range indication:** '19999' or '19999' blinking for display values out of the display range.

'S.ERR' and 'Min' or 'Max' blinking when the input signal is out of the usable range.

### Alarm status indication

**LL indicator:** Green LED turns on when the LL alarm is tripped.

**L indicator:** Green LED turns on when the L alarm is tripped.

**H indicator:** Red LED turns on when the H alarm is tripped.

**HH indicator:** Red LED turns on when the HH alarm is tripped.

**P indicator:** Amber LED turns on when none of the other alarms is tripped.

Only 'P' turns on with no-alarm-output type. 'LL' or 'HH' does not turn on with dual-alarm-output type.

All setpoints can be independently set either for Hi or Lo alarm trip.

### Function indicators:

Zro, Spn, D/P, Tch, Fnc, Min, Max

Display mode status and operation status, amber ON or blink

**Engineering unit indication:** Sticker label attached

DC, AC, mV, V, kV, μA, mA, A, kA, mW, W, kW, var, kvar, Mvar, VA, Hz, Ω, kΩ, MΩ, cm, mm, m, m/sec, mm/min, cm/min, m/min, m/h, m/s<sup>2</sup>, inch, l, l/s, l/min, l/h, m<sup>3</sup>, m<sup>3</sup>/sec, m<sup>3</sup>/min, m<sup>3</sup>/h, Nm<sup>3</sup>/h, N·m, N/m<sup>2</sup>, g, kg, kg/h, N, kN, Pa, kPa, MPa, t, t/h, °C, °F, %RH, J, kJ, MJ, rpm, sec, min, min<sup>-1</sup>, pH, %, ppm, etc.

## INPUT SPECIFICATIONS

### Default setting

**Input code 1:** Measuring range ±10 V

**Input code 2:** Measuring range ±1 V

**Input code 3:** Measuring range ±200 V

**Input code 4:** Measuring range ±100 μA

**Input code 5:** Measuring range ±2 A

**Input code 6:** Measuring range ±700 V

### Overload capacity

**Input code 5:** ±3 A for 10 sec., ±2.4 A continuous

**Input code 6:** ±1000 V for 10 sec., ±840 V continuous

#### ■ INPUT CODE: 1

TYPE IND	MEASURING RANGE	OPERATIONAL RANGE	INPUT IMPEDANCE
V10	±10 V	-11 – +11 V	≥ 1 MΩ
V5	±5 V	-5.5 – +5.5 V	≥ 1 MΩ
V0-5	0 – 5 V	-0.3 – +5.3 V	≥ 1 MΩ
V1-5	1 – 5 V	0.7 – 5.3 V	≥ 1 MΩ
A0-2	0 – 20 mA	-2 – +22 mA	approx. 10 Ω
A4-2	4 – 20 mA	2 – 22 mA	approx. 10 Ω

#### ■ INPUT CODE: 2

TYPE IND	MEASURING RANGE	OPERATIONAL RANGE	INPUT IMPEDANCE
V1	±1 V	-1.1 – +1.1 V	≥ 1 MΩ
V01	±100 mV	-110 – +110 mV	≥ 1 MΩ
V001	±10 mV	-11 – +11 mV	≥ 1 MΩ
A1	±1 mA	-1.1 – +1.1 mA	approx. 100 Ω

#### ■ INPUT CODE: 3

TYPE IND	MEASURING RANGE	OPERATIONAL RANGE	INPUT IMPEDANCE
V200	±200 V	-220 – +220 V	≥ 1 MΩ
A100	±100 mA	-110 – +110 mA	approx. 10 Ω

#### ■ INPUT CODE: 4

TYPE IND	MEASURING RANGE	OPERATIONAL RANGE	INPUT IMPEDANCE
A01	±100 μA	-110 – +110 μA	approx. 1 kΩ

#### ■ INPUT CODE: 5

TYPE IND	MEASURING RANGE	OPERATIONAL RANGE	INPUT IMPEDANCE
A2-2	±2 A	-2.2 – +2.2 A	approx. 0.1 Ω
A1-1	±1 A	-1.1 – +1.1 A	approx. 0.1 Ω

#### ■ INPUT CODE: 6

TYPE IND	MEASURING RANGE	OPERATIONAL RANGE	INPUT IMPEDANCE
V700	±700 V	-770 – +770 V	≥ 1 MΩ

## OUTPUT SPECIFICATIONS

### ■ DC Output

- DC Current

**Operational range:** -5 – +105 %

- DC Voltage

**Operational range:** -5 – +105 %

- Alarm Output: Relay contact

**Rated load:** 250 V AC @ 3 A ( $\cos \phi = 1$ )  
30 V DC @ 3 A (resistive load)  
**Maximum switching voltage:** 250 V AC, 30 V DC  
**Maximum switching power:** 750 VA, 90 W (resistive load)  
**Minimum load:** 5 V DC @ 10 mA  
**Mechanical life:**  $\geq 5 \times 10^6$  cycles (rate 180 cycles/min.)

## INSTALLATION

### Power consumption

- AC: Approx. 6.5VA
- DC: Approx. 3 W

**Operating temperature:** -10 to +55°C (14 to 131°F)

**Operating humidity:** 30 to 90 %RH (non-condensing)

**Mounting:** Panel flush mounting

**Weight:** 300 g (0.66 lb)

## PERFORMANCE

### Accuracy

**Display:**  $\pm 0.1 \% \pm 1$  digit

$\pm 0.2 \% \pm 1$  digit for  $\pm 10$  mV range

**Output:**  $\pm 0.1 \%$  (DC output = display + output)

**Temp. coefficient:**  $\pm 0.015 \% / ^\circ\text{C}$  ( $\pm 0.008 \% / ^\circ\text{F}$ )

$\pm 0.03 \% / ^\circ\text{C}$  ( $\pm 0.02 \% / ^\circ\text{F}$ ) for  $\pm 10$  mV range

**Input resolution:** Max. 16 bits

**Output resolution:** Max. 14 bits

**Response time:**  $\leq 0.5$  sec.

(alarm output: 0 - 100 % at 90 % setpoint)

$\leq 0.5$  sec. (DC output: 0 - 90 %)

**Line voltage effect:**  $\pm 0.1 \%$  over voltage range

**Insulation resistance:**  $\geq 100 \text{ M}\Omega$  with 500 V DC

**Dielectric strength:** 2000 V AC @ 1 minute (input to DC output to HH output or H output to L output or LL output to power to ground)

## STANDARDS & APPROVALS

### EU conformity:

EMC Directive

EMI EN 61000-6-4

EMS EN 61000-6-2

Low Voltage Directive

EN 61010-1

Measurement Category II (alarm output)

Installation Category II (power)

Pollution degree 2

Input or DC output to alarm output to power: Reinforced insulation (300 V)

Input to DC output: Basic insulation (300 V)

RoHS Directive

**Protection against access to the terminal blocks:**

Finger protection (VDE 0660-514)

## EXTERNAL VIEW

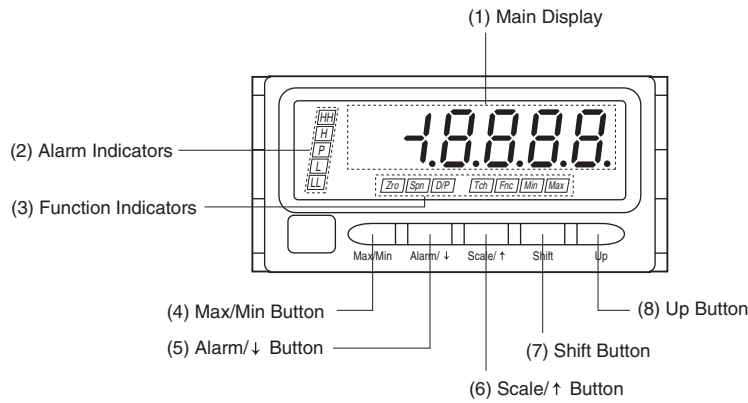

### • COMPONENT IDENTIFICATION

No.	COMPONENT	FUNCTION
(1)	Main display	Indicates present values, setting values and status of the unit.
(2)	Alarm indicators	Indicate alarm status of the input signal.
(3)	Function indicators	Indicate the status in each setting mode.
(4)	Max/Min button	Used to switch the main display to show the present values, maximum values or minimum values etc.
(5)	Alarm/↓ button	Used to confirm alarm setting value and to move on to the alarm and other setting modes; or to shift through setting items in each setting mode.
(6)	Scale/↑ button	Used to move on to the scaling and other setting modes; or to shift through setting items in each setting mode.
(7)	Shift button	Used to move on to the setting standby status of each setting mode and shift through display digits in each setting mode.
(8)	Up button	Used to change setting values, to execute/cancel Forced Zero or to select setting values.

Note: Refer to the operating manual for details on each function.

**EXTERNAL DIMENSIONS & TERMINAL ASSIGNMENTS unit: mm (inch)**

■ TOP VIEW

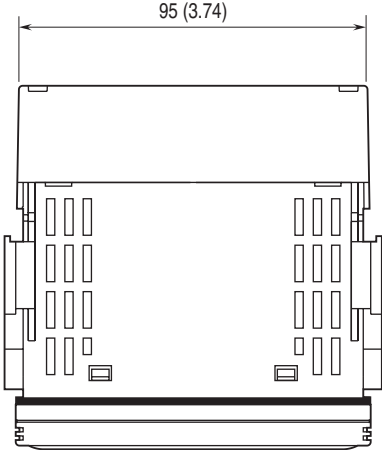

■ FRONT VIEW

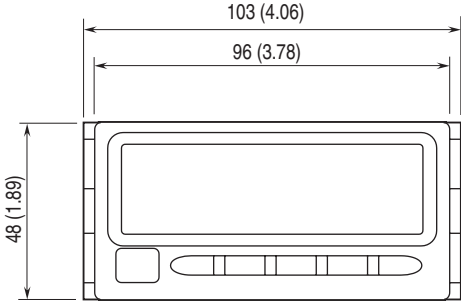

■ SIDE VIEW

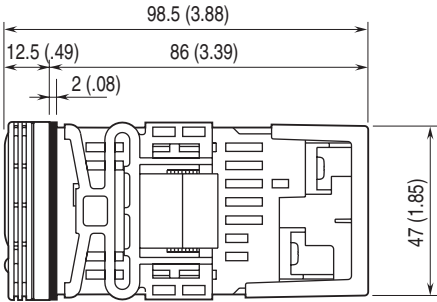

■ REAR VIEW

• No Alarm Output

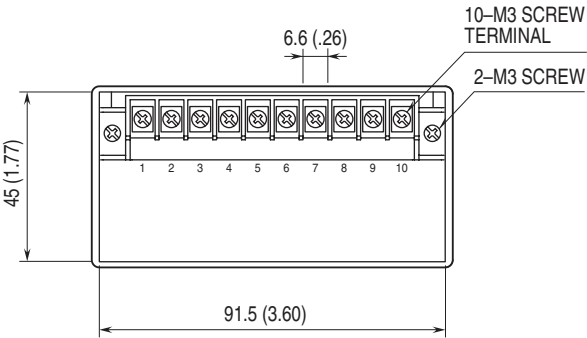

• Alarm Output

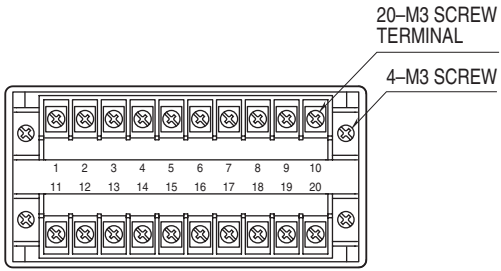

**MOUNTING REQUIREMENTS unit: mm**

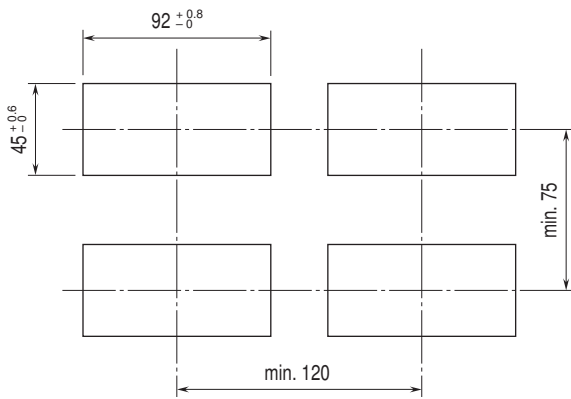

Panel thickness: 1.6 to 8.0 mm

**SCHEMATIC CIRCUITRY & CONNECTION DIAGRAM**

■ ALARM OUTPUT CODE 0: No alarm output

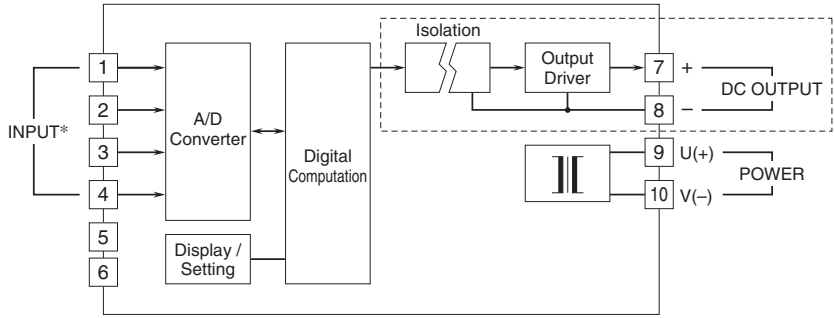

■ ALARM OUTPUT CODE 1: N.O. contact, 4 points

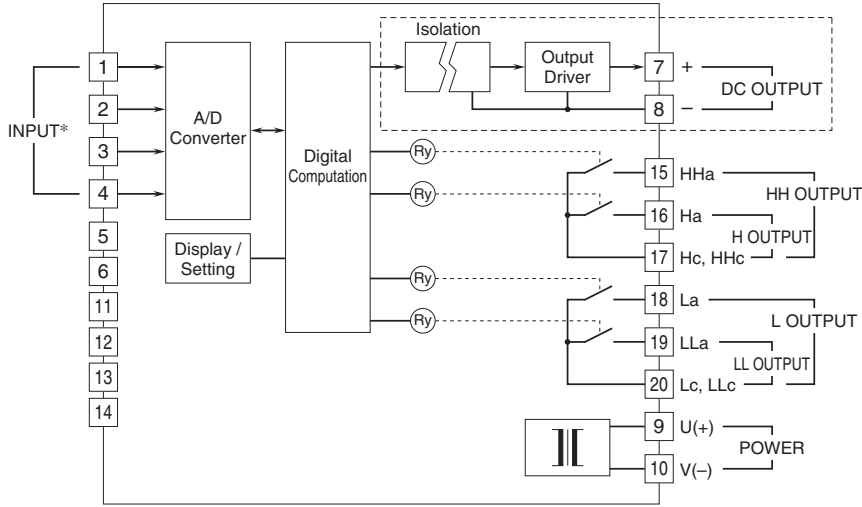

■ ALARM OUTPUT CODE 2: SPDT contact, 2 points

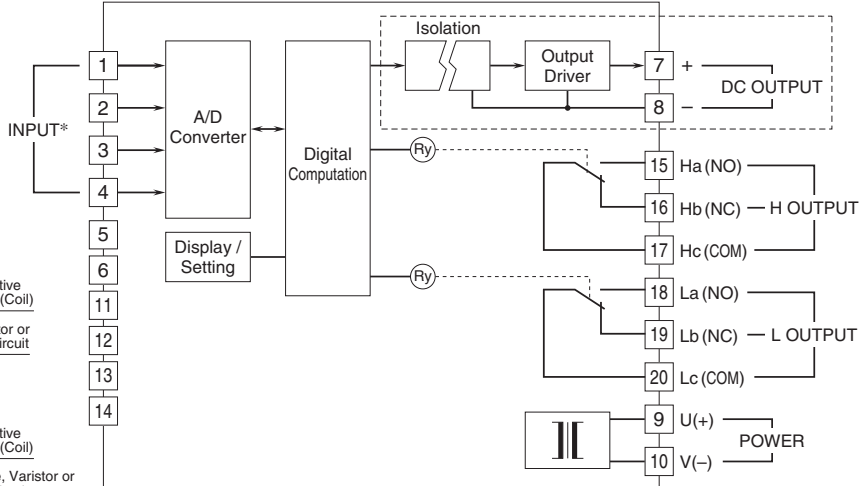

■ Relay Protection

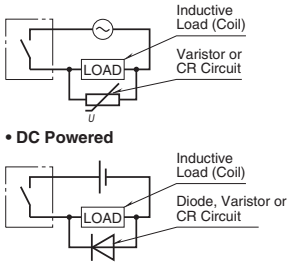

Note: The section enclosed by broken line is only with DC output option.

\* Input shunt resistor incorporated for current input.

• Input code: 1, 2

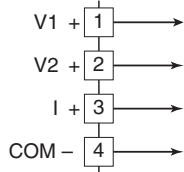

• Input code: 3

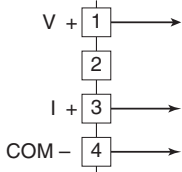

• Input code: 4

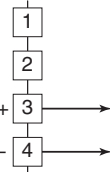

• Input code: 5, 6

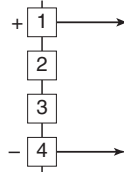

• Input Terminal Assignments

INPUT TYPE (indicator)	MEASURING RANGE	INPUT TERMINALS	INPUT TYPE (indicator)	MEASURING RANGE	INPUT TERMINALS
V200 V10 V5 V1 A2-2 A1-1 V700	±200V ±10V ±5V ±1V ±2A ±1A ±700V	[1]-[4]	V0-5 V1-5 A100 A1 A0-2 A4-2 A01	0 – 5V 1 – 5V ±100mA ±1mA 0 – 20mA 4 – 20mA ±100µA	[2]-[4]  [3]-[4]
V01 V001	±100mV ±10mV	[2]-[4]			



Specifications are subject to change without notice.