

Limit Alarms (rotary switch adj.) AL-UNIT

U: Specify voltage (See INPUT SPECIFICATIONS)
(0 % input must be 0 V.)

TACHOGENERATOR ALARM

Functions & Features

- Providing SPDT relay outputs at preset AC voltage levels from a tachogenerator
- Dual (Hi/Lo) trip
- Energized or de-energized coil at a tripped condition selectable
- Rotary switch setpoint adjustments
- Enclosed relays
- Relays can be powered 110 V DC
- High-density mounting

Typical Applications

- Annunciator
- Various alarm applications

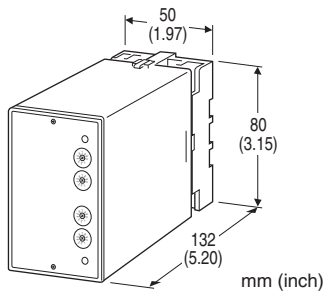

MODEL: ALTG-[1][2][3]-[4][5]

ORDERING INFORMATION

- Code number: ALTG-[1][2][3]-[4][5]
- Specify a code from below for each of [1] through [5].
(e.g. ALTG-111-B/Q)
- Special input range (For code U)
- Specify the specification for option code /Q
(e.g. /C01/S01)

[1] INPUT

Voltage

- 1: 0 - 35 V AC (Input resistance 100 kΩ min.)
- 2: 0 - 50 mV AC (Input resistance 100 kΩ min.)
- 3: 0 - 60 mV AC (Input resistance 100 kΩ min.)
- 4: 0 - 100 mV AC (Input resistance 100 kΩ min.)
- 5: 0 - 1 V AC (Input resistance 100 kΩ min.)
- 6: 0 - 10 V AC (Input resistance 100 kΩ min.)
- 7: 0 - 100 V AC (Input resistance 100 kΩ min.)
- 8: 0 - 110 V AC (Input resistance 100 kΩ min.)
- 9: 0 - 150 V AC (Input resistance 100 kΩ min.)
- A: 0 - 200 V AC (Input resistance 100 kΩ min.)
- B: 0 - 250 V AC (Input resistance 100 kΩ min.)

[2] SETPOINT 1 OUTPUT

- 1: Hi (coil energized at alarm)
- 2: Hi (coil de-energized at alarm)
- 3: Lo (coil energized at alarm)
- 4: Lo (coil de-energized at alarm)

[3] SETPOINT 2 OUTPUT

- 1: Hi (coil energized at alarm)
- 2: Hi (coil de-energized at alarm)
- 3: Lo (coil energized at alarm)
- 4: Lo (coil de-energized at alarm)

[4] POWER INPUT

AC Power

- B: 100 V AC
- C: 110 V AC
- D: 115 V AC
- F: 120 V AC
- G: 200 V AC
- H: 220 V AC
- J: 240 V AC

DC Power

- S: 12 V DC
- R: 24 V DC
- V: 48 V DC
- P: 110 V DC

[5] OPTIONS

- blank: none
- /Q: With options (specify the specification)

SPECIFICATIONS OF OPTION: Q (multiple selections)

COATING (For the detail, refer to M-System's web site.)

- /C01: Silicone coating
- /C02: Polyurethane coating
- /C03: Rubber coating

TERMINAL SCREW MATERIAL

- /S01: Stainless steel

GENERAL SPECIFICATIONS

Construction: Plug-in

Connection: M3.5 screw terminals

Screw terminal: Chromated steel (standard) or stainless steel

Housing material: Flame-resistant resin (black)

Isolation: Input to output 1 to output 2 to power

Setpoint adjustments: 10-position rotary switches (front); 0

- 99 % independently; 1 % increments

Hysteresis (deadband): 0.7 - 2.5 %

Front LEDs: Red LED turns on when the coil is energized.

Power ON timer: Relays de-energized for approx. 2 seconds after power is turned on.

INPUT SPECIFICATIONS

• **AC Voltage:** 0 - 250 V AC

Minimum span: 50 mV

Frequency: 15 Hz min., 1 kHz max. with 100 % input

Input resistance: $\geq 100 \text{ k}\Omega$

OUTPUT SPECIFICATIONS

■ **Relay Contact:** 100 V AC @ 1 A ($\cos \phi = 1$)

120 V AC @ 1 A ($\cos \phi = 1$)

240 V AC @ 0.5 A ($\cos \phi = 1$)

30 V DC @ 1 A (resistive load)

Maximum switching voltage: 380 V AC or 125 V DC

Maximum switching power: 120 VA or 30 W

Minimum load: 5 V DC @ 10 mA

Mechanical life: 5×10^7 cycles

For maximum relay life with inductive loads, external protection is recommended.

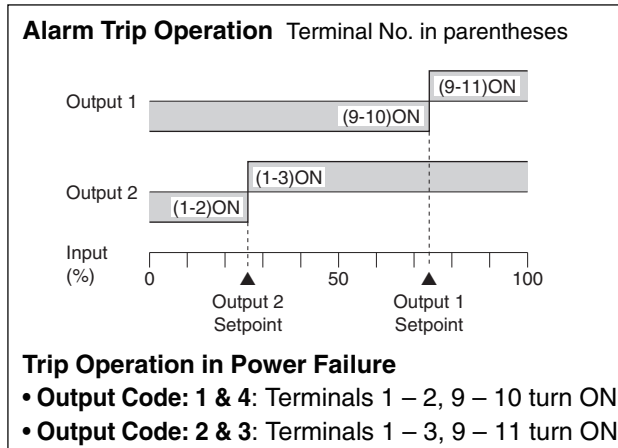

INSTALLATION

Power input

• **AC:** Operational voltage range: rating $\pm 10 \%$, 50/60 ± 2 Hz, approx. 2 VA

• **DC:** Operational voltage range: rating $\pm 10 \%$, or 85 - 150 V for 110 V rating (ripple 10 % p-p max.) approx. 2 W (80 mA at 24 V)

Operating temperature: -5 to +60°C (23 to 140°F)

Operating humidity: 30 to 90 %RH (non-condensing)

Mounting: Surface or DIN rail

Weight: 370 g (0.82 lb)

PERFORMANCE in percentage of span

Setpoint accuracy: $\pm 0.9 \%$

Trip point repeatability: $\pm 0.05 \%$

Temp. coefficient: $\pm 0.015 \%/^{\circ}\text{C}$ ($\pm 0.008 \%/^{\circ}\text{F}$)

Response time: Approx. 0.5 sec. (0 - 100 % at 90 % setpoint)

Line voltage effect: $\pm 0.1 \%$ over voltage range

Insulation resistance: $\geq 100 \text{ M}\Omega$ with 500 V DC

Dielectric strength: 2000 V AC @1 minute (input to output 1 to output 2 to power to ground)

EXTERNAL VIEW

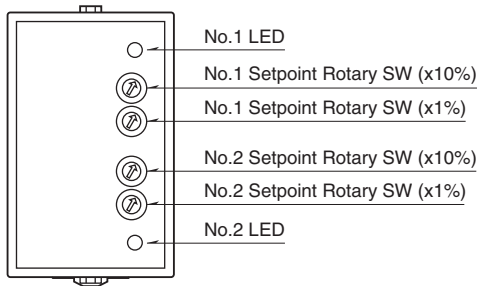

EXTERNAL DIMENSIONS & TERMINAL ASSIGNMENTS unit: mm (inch)

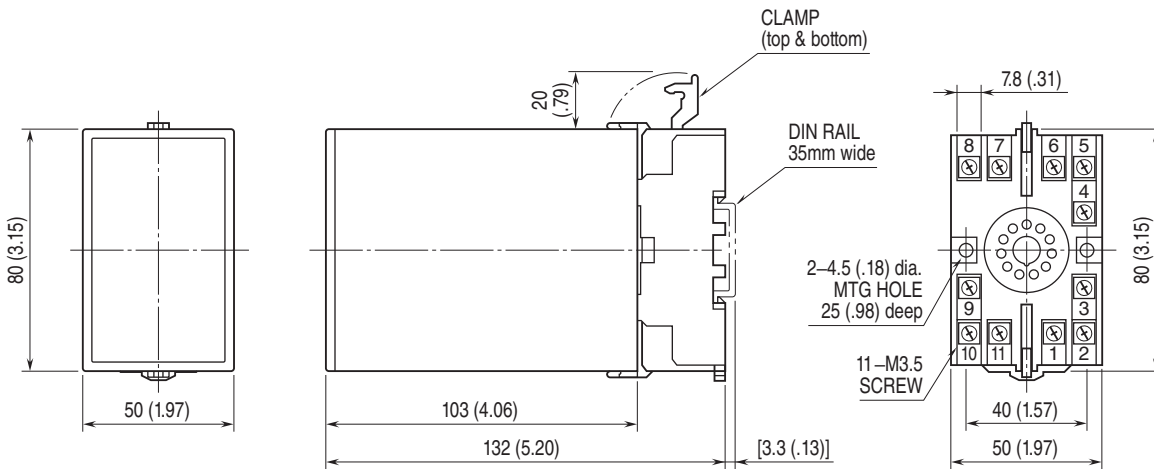

• When mounting, no extra space is needed between units.

SCHEMATIC CIRCUITRY & CONNECTION DIAGRAM

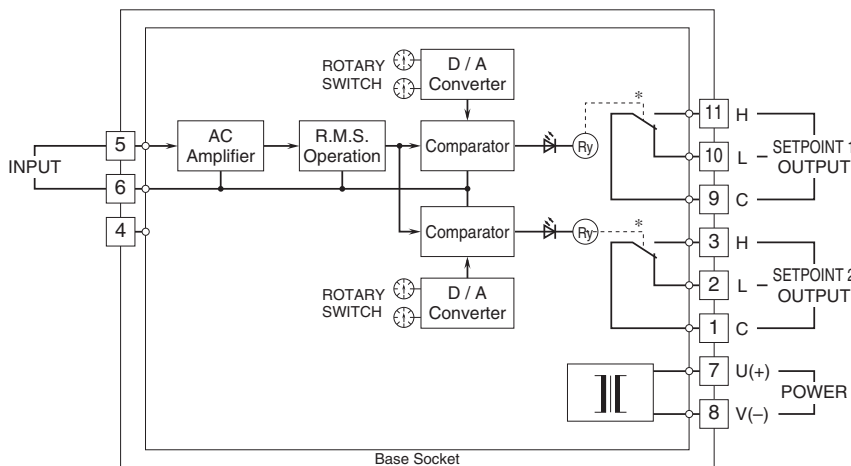

*Relay status for output codes "1" & "4", at power OFF.

■ Relay Protection

• AC Powered

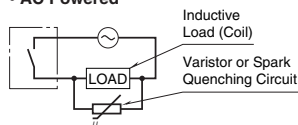

• DC Powered

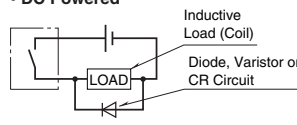



Specifications are subject to change without notice.