

TS-SS-13-X.X Drawing

**Note: Screw needs to be calibrated for a specific torque.
Use part numbers shown in the table below to order appropriate screw**

Top View

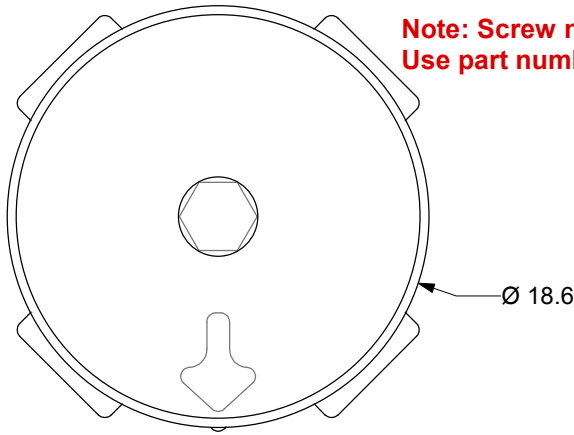

- ① Compression Screw Top: Clear anodized Aluminum.
- ② Compression Screw Bottom: Black anodized Aluminum M6 x1x6g Thread.

Side View

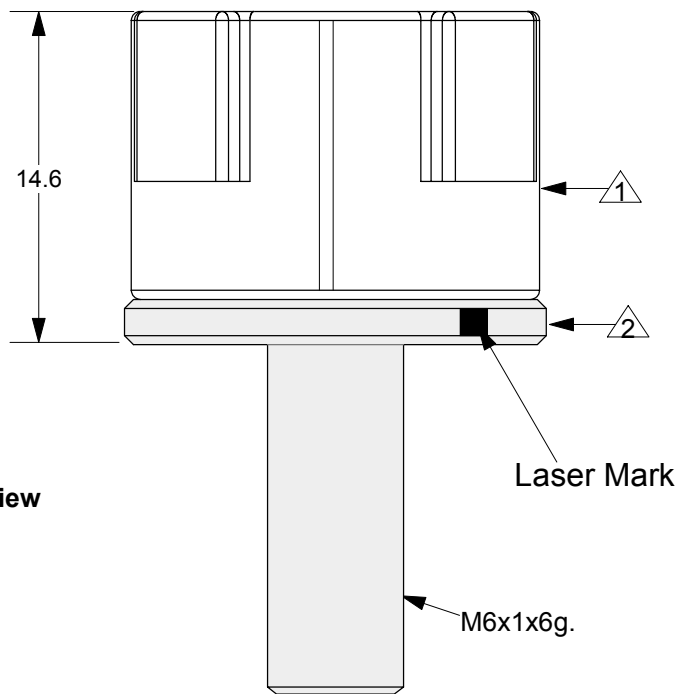

Ordering Information

<u>Part Number</u>	<u>Torque (in. lbs)</u>
TS-SS-03-0.5	0.5
TS-SS-03-0.75	0.75
TS-SS-03-1.0	1.0
TS-SS-03-1.25	1.25
TS-SS-03-1.5	1.5
TS-SS-03-1.75	1.75
TS-SS-03-2	2.0

Description: SS Type-Torque Indicating Screw
Torque screw for 0 in lbs -2.2 in lbs

To be used with Clamshell lid sockets.
Compression screw needs to be turned clockwise up to the point where the arrow on top of the compression screw aligns with laser mark on the compression screw bottom.

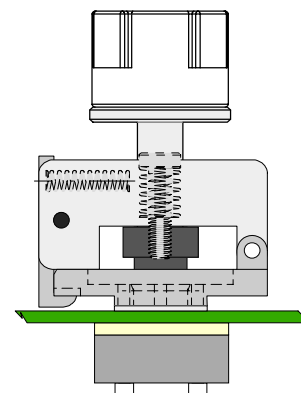

Clamshell socket with Torque Indicating Screw

Tolerances: All tolerances are ±0.13mm [±0.005"] unless stated otherwise. Materials and specifications are subject to change without notice.

	TS-SS-13-X.X Drawing	Status: Released	Scale: N/A	Rev: B
	© 2008 IRONWOOD ELECTRONICS, INC. Tele: (952) 229-8200 www.ironwoodelectronics.com	Drawing: Vinayak R		Date: 5/27/08
		File: TS-SS-13-X_X Dwg		Modified: 8/10/09