



2.0x1.6mm Auto Grade Oscillator

O1HA DATASHEET

AEC Q200 Qualified
 IATF-16949 QMS
 Stabilities to ± 25 PPM
 Temperature Ranges as wide as -40°C to $+125^{\circ}\text{C}$
 Supply Voltages: 1.8V; 2.5V; 3.3V; 1.7V~3.63V

1.8V ELECTRICAL CHARACTERISTICS

PARAMETERS	MAX (unless otherwise noted)
Frequency Range (F_o)	1.250 ~ 60.000MHz
Storage Temperature Range (T_{STG})	$-55 \sim +150^{\circ}\text{C}$
Supply Voltage (V_{DD})	1.8V $\pm 5\%$
Input Current (I_{DD})	
1.250 ~ <10.000MHz	3 mA
10.000 ~ <32.000MHz	5 mA
32.000 ~ 60.000MHz	10 mA
Standby Current	
$T_{OPR} = -40 \sim +85^{\circ}\text{C}$	10 μA
$T_{OPR} = -40 \sim +105^{\circ}\text{C} / -40 \sim +125^{\circ}\text{C}$	20 μA
Output Symmetry (50% V_{DD})	45% ~ 55%
Rise Time (10%~90% V_{DD})	5 nS
Fall Time (90%~10% V_{DD})	5 nS
Output Voltage (V_{OL})	10% V_{DD}
(V_{OH})	90% V_{DD} Min
Output Load (HCMOS)	15 pF
Start-up Time (T_s)	10 mS
Output Disable Time ¹	200 nS
Output Enable Time ¹	10 mS
Aging (per year @ 25C)	± 5 PPM

ENABLE / DISABLE FUNCTION

Pin1	Output (pin 3)
OPEN ¹	Active
'1' Level $V_{IH} \geq 70\%V_{DD}$	Active
'0' Level $V_{IL} \leq 30\%V_{DD}$	High Z

• Available Options by Stability & Operating Temp for 1.8V²

Frequency Stability	Operating Temperature ($^{\circ}\text{C}$)	Frequency Range (MHz)
± 100 PPM	$-40 \sim +85$	1.250 ~ 60.000
± 100 PPM	$-40 \sim +105$	1.250 ~ 60.000
± 100 PPM	$-40 \sim +125$	1.250 ~ 60.000
± 50 PPM	$-40 \sim +85$	1.250 ~ 60.000
± 50 PPM	$-40 \sim +105$	1.250 ~ 60.000
± 50 PPM	$-40 \sim +125$	1.250 ~ 60.000
± 25 PPM	$-40 \sim +85$	1.250 ~ 60.000

¹ An internal pull-up resistor from pin 1 to pin 4 allows active output if pin 1 is left open

² Inclusive of 25 $^{\circ}\text{C}$ tolerance and operating temperature range.

7/29/2020 Updated termination finish and MSL info

© Copyright 2020 Fox Electronics. All rights reserved

Title / Description: O1HA SERIES STANDARD SPECIFICATIONS

Drawing Number: O1HA-DOC-1

Part Number:

Draftsperson: BEC

Revision: C

Cage: 61429

Approved: MAJ

Revision Date: 07/29/2020



2.5V ELECTRICAL CHARACTERISTICS

PARAMETERS	MAX (unless otherwise noted)
Frequency Range (F _o)	1.250 ~ 60.000MHz
Storage Temperature Range (T _{STG})	-55 ~ +150°C
Supply Voltage (V _{DD})	2.5V±5%
Input Current (I _{DD})	
1.250 ~ <10.000MHz	6 mA
10.000 ~ <32.000MHz	8 mA
32.000 ~ 60.000MHz	20 mA
Standby Current	
T _{OPR} = -40 ~ +85°C	10 µA
T _{OPR} = -40 ~ +105°C / -40 ~ +125°C	20 µA
Output Symmetry (50% V _{DD})	45% ~ 55%
Rise Time (10%~90% V _{DD})	5 nS
Fall Time (90%~10% V _{DD})	5 nS
Output Voltage (V _{OL})	10% V _{DD}
(V _{OH})	90% V _{DD} Min
Output Load (HCMOS)	15 pF
Start-up Time (T _s)	10 mS
Output Disable Time ¹	200 nS
Output Enable Time ¹	10 mS
Aging (per year @ 25C)	±5 PPM

ENABLE / DISABLE FUNCTION

Pin1	Output (pin 3)
OPEN ¹	Active
'1' Level V _{IH} ≥ 70%V _{DD}	Active
'0' Level V _{IL} ≤ 30%V _{DD}	High Z

• Available Options by Stability & Operating Temp for 2.5V²

Frequency Stability	Operating Temperature (°C)	Frequency Range (MHz)
±100PPM	-40 ~ +85	1.250 ~ 60.000
±100PPM	-40 ~ +105	1.250 ~ 60.000
±100PPM	-40 ~ +125	1.250 ~ 60.000
±50PPM	-40 ~ +85	1.250 ~ 60.000
±50PPM	-40 ~ +105	1.250 ~ 60.000
±50PPM	-40 ~ +125	1.250 ~ 60.000
±25PPM	-40 ~ +85	1.250 ~ 60.000

¹ An internal pull-up resistor from pin 1 to pin 4 allows active output if pin 1 is left open

² Inclusive of 25°C tolerance and operating temperature range.

7/29/2020 Updated termination finish and MSL info

© Copyright 2020 Fox Electronics. All rights reserved

Title / Description: O1HA SERIES STANDARD SPECIFICATIONS

Drawing Number: O1HA-DOC-1

Part Number:

Draftsperson: BEC

Revision: C

Cage: 61429

Approved: MAJ

Revision Date: 07/29/2020



3.3V ELECTRICAL CHARACTERISTICS

PARAMETERS	MAX (unless otherwise noted)
Frequency Range (F _o)	1.250 ~ 60.000MHz
Storage Temperature Range (T _{STG})	-55 ~ +150°C
Supply Voltage (V _{DD})	3.3V±10%
Input Current (I _{DD})	
1.250 ~ <20.000MHz	7 mA
20.000 ~ <32.000MHz	12 mA
32.000 ~ 50.000MHz	20 mA
>50.000 ~ 60.000MHz	25 mA
Standby Current	
T _{OPR} = -40 ~ +85°C	10 µA
T _{OPR} = -40 ~ +105°C / -40 ~ +125°C	20 µA
Output Symmetry (50% V _{DD})	45% ~ 55%
Rise Time (10%~90% V _{DD})	5 nS
Fall Time (90%~10% V _{DD})	5 nS
Output Voltage (V _{OL})	10% V _{DD}
(V _{OH})	90% V _{DD} Min
Output Load (HCMOS)	15 pF
Start-up Time (T _s)	10 mS
Output Disable Time ¹	200 nS
Output Enable Time ¹	10 mS
Aging (per year @ 25C)	±5 PPM

ENABLE / DISABLE FUNCTION

Pin1	Output (pin 3)
OPEN ¹	Active
'1' Level V _{IH} ≥ 70%V _{DD}	Active
'0' Level V _{IL} ≤ 30%V _{DD}	High Z

• Available Options by Stability & Operating Temp for 3.3V²

Frequency Stability	Operating Temperature (°C)	Frequency Range (MHz)
±100PPM	-40 ~ +85	1.250 ~ 60.000
±100PPM	-40 ~ +105	1.250 ~ 60.000
±100PPM	-40 ~ +125	1.250 ~ 60.000
±50PPM	-40 ~ +85	1.250 ~ 60.000
±50PPM	-40 ~ +105	1.250 ~ 60.000
±50PPM	-40 ~ +125	1.250 ~ 60.000
±25PPM	-40 ~ +85	1.250 ~ 60.000

¹ An internal pull-up resistor from pin 1 to pin 4 allows active output if pin 1 is left open

² Inclusive of 25°C tolerance and operating temperature range.

7/29/2020 Updated termination finish and MSL info

© Copyright 2020 Fox Electronics. All rights reserved

Title / Description: O1HA SERIES STANDARD SPECIFICATIONS

Drawing Number: O1HA-DOC-1

Part Number:

Draftsperson: BEC

Revision: C

Cage: 61429

Approved: MAJ

Revision Date: 07/29/2020

**VARIABLE VOLTAGE ELECTRICAL CHARACTERISTICS**

PARAMETERS	MAX (unless otherwise noted)
Frequency Range (F ₀)	1.25 ~ 135 MHz
Storage Temperature Range (T _{STG})	-55 ~ +125°C
Supply Voltage (V _{DD})	1.7V ~ 3.63V
Input Current (I _{DD})	
1.25 ~ 19.999MHz	4 mA
20.0 ~ 39.999MHz	6 mA
40.0 ~ 59.999MHz	10 mA
60.0 ~ 80MHz	15 mA
>80.0 ~ 135.0MHz	30 mA
Standby Current	
T _{OPR} = -40 ~ +85°C	10 μA
T _{OPR} = -40 ~ +105°C / -40 ~ +125°C	20 μA
Output Symmetry (50% V _{DD})	
1.25 ~ 80MHz	45% ~ 55%
>80.0 ~ 135MHz	40% ~ 60%
Rise/Fall Time (10%/90% V _{DD} Levels) (T _R /T _F)	6 nS
Output Voltage (V _{OL})	10% V _{DD}
(V _{OH})	90% V _{DD} Min
Output Load (HCMOS)	15 pF
Start-up Time (T _S)	5 mS
Output Disable Time ¹	200 nS
Output Enable Time ¹	5 mS
Aging (per year @ 25C)	±5 PPM

ENABLE / DISABLE FUNCTION

Pin1	Output (pin 3)
OPEN ¹	Active
'1' Level V _{IH} ≥ 70%V _{DD}	Active
'0' Level V _{IL} ≤ 30%V _{DD}	High Z

• Available Options by Stability & Operating Temp²

Frequency Stability	Operating Temperature (°C)	Frequency Range (MHz)
±100PPM	-40 ~ +85	1.250 ~ 135.000
±100PPM	-40 ~ +105	1.250 ~ 135.000
±100PPM	-40 ~ +125	1.250 ~ 135.000
±50PPM	-40 ~ +85	1.250 ~ 135.000
±50PPM	-40 ~ +105	1.250 ~ 135.000
±50PPM	-40 ~ +125	1.250 ~ 135.000
±25PPM	-40 ~ +85	1.250 ~ 135.000

¹ An internal pull-up resistor from pin 1 to pin 4 allows active output if pin 1 is left open² Inclusive of 25°C tolerance and operating temperature range.

7/29/2020 Updated termination finish and MSL info

Title / Description: O1HA SERIES STANDARD SPECIFICATIONS**Drawing Number:** O1HA-DOC-1**Revision:** C**Part Number:****Cage:** 61429**Draftsperson:** BEC**Approved:** MAJ**Revision Date:** 07/29/2020

© Copyright 2020 Fox Electronics. All rights reserved



DIMENSIONS / MECHANICAL SPECIFICATIONS

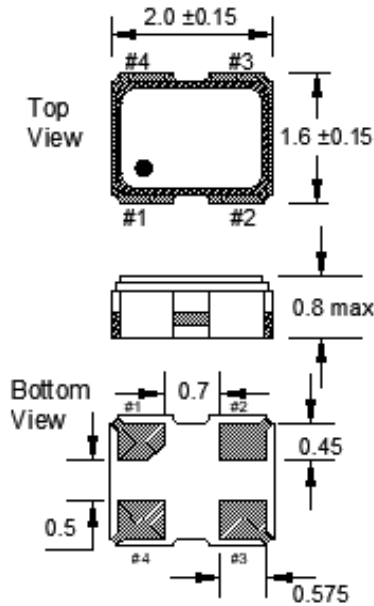

Recommended Solder Pad Layout

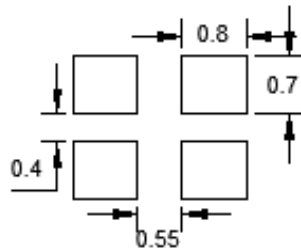

Dimensions are in millimeters.

Pin Connections

#1 E/D #3 Output
#2 GND #4 V_{DD}

Maximum Soldering Temp / Time	260°C / 10 Seconds x 2
Moisture Sensitivity Level (MSL) per J-STD-033	N/A
Termination Finish	Au (0.3~1µm) over Ni (1.27~8.89µm)
Seal Method	Seam
Lead (Pb) Free	Yes
RoHS Compliant	Yes, no exemptions
REACH Compliant (latest version)	Yes

Notes:

*A 0.01µF capacitor should be placed between V_{DD} (Pin 4) and GND (Pin2) to minimize power supply line noise.

*Dimensional drawing is for reference to critical specifications defined by size measurements.

Certain non-critical visual attributes, such as side castellations, reference pin shape, etc. may vary

7/29/2020 Updated termination finish and MSL info

Title / Description: O1HA SERIES STANDARD SPECIFICATIONS

Drawing Number: O1HA-DOC-1

Revision: C

Part Number:

Cage: 61429

Draftsperson: BEC

Approved: MAJ

Revision Date: 07/29/2020

© Copyright 2020 Fox Electronics. All rights reserved



2.0x1.6mm Auto Grade Oscillator

O1HA DATASHEET

Tape Specifications (millimeters)							Reel Specifications (millimeters)						
A	B	C	D	E	F	Reel Qty	G	H	I	J	K	L	M
Ø1.5	4.0	4.0	3.5	8.0	1.15	-T3 = 3,000 -T2 = 2,000 -T1 = 1,000	2.0	Ø13	Ø21	Ø60	Ø180	9.0	1.7

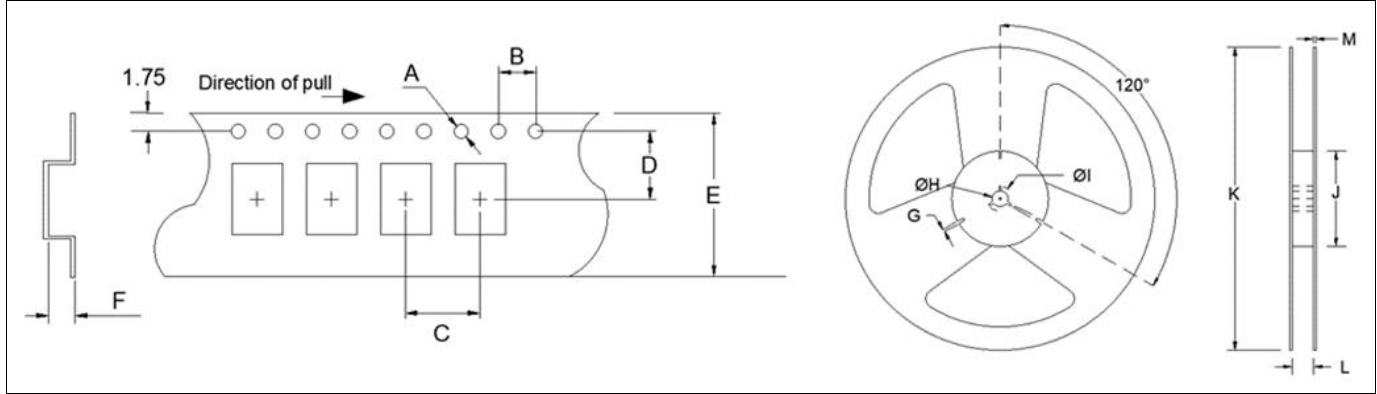

Available Options & Part Identification*

Example: F O1HA C B P 25.0

F	O1HA	C	B	P	25.0
Fox	Model Number	Voltage	Stability	Operating Temperature	Frequency (MHz)
		K = 1.8V±5% H = 2.5V±5% C = 3.3V±10% V = 1.7V ~ 3.63V	A = ±100PPM B = ±50PPM D = ±25PPM	M = -40 to +85°C P = -40 to +105°C I = -40 to +125°C	

*Not all frequencies in the frequency range, nor every combination of stability, temp range, and voltage available. See stabilities and op temps for each VDD.



Corporate Headquarters
5570 Enterprise Parkway
Fort Myers, FL 33905
<http://www.FOXONLINE.com>

Sales
1-888-GET-2-FOX (1-888-438-2369)
or
1-239-693-0099
<http://www.FOXONLINE.com/repdisty>

Tech Support
<http://www.FOXONLINE.com/email>

Product use: Fox Electronics reserves the right to modify the products and/or specifications described herein at any time and at Fox Electronics' sole discretion. All information in this document, including descriptions of product features and performance, is subject to change without notice. Performance specifications and the operating parameters of the described products are determined in the independent state and are not guaranteed to perform the same way when installed in customer products. The information contained herein is provided without representation or warranty of any kind, whether express or implied, including, but not limited to, the suitability of Fox Electronics' products for any particular purpose, an implied warranty of merchantability, or non-infringement of the intellectual property rights of others. This document is presented only as a guide and does not convey any license under intellectual property rights of Fox Electronics or any third parties. Fox Electronics' products are not intended for use in applications involving extreme environmental conditions or in life support systems or similar devices where the failure or malfunction of a Fox Electronics product can be reasonably expected to significantly affect the health or safety of users. Anyone using a Fox Electronics product in such a manner does so at their own risk, absent an express, written agreement by Fox Electronics. Fox Electronics and the Fox logo are registered trademarks of Fox Electronics. Product specification is subject to change without notice. Other trademarks and service marks used herein, including protected names, logos and designs, are the property of Fox Electronics or their respective third-party owners.

7/29/2020 Updated termination finish and MSL info

© Copyright 2020 Fox Electronics. All rights reserved

Title / Description: O1HA SERIES STANDARD SPECIFICATIONS		
Drawing Number: O1HA-DOC-1	Revision: C	
Part Number:	Cage: 61429	
Draftsperson: BEC	Approved: MAJ	Revision Date: 07/29/2020