

PAD	CONNECTION
1	Enable / disable
2	Not connected
3	Ground
4	Output 1
5	Output 2
6	Supply

Features

- ▶ Complementary LV-PECL output
- ▶ RMS phase jitter 0.3ps
- ▶ Multiplier-free design
- ▶ Enable / disable tristate function
- ▶ Designed for high speed data transfer

Example Applications

- ▶ Networking - Gigabit ethernet etc
- ▶ Storage - SAS, SATA etc
- ▶ Telecomms - SONET, SDH etc
- ▶ Computing
- ▶ Instrumentation

Specifications

Parameters	Variant		Option Codes
	L	J	
Frequency range: 40.0 ~ 60.0MHz (fundamental) 60.0 ~ 160MHz (3rd OT) 160.0 ~ 250MHz (inverted mesa)	■	■	
Frequency stability*: ±100ppm ±50ppm ±25ppm (<170MHz)	■ □ □	■ □ □	B A
Operating temperature range: -10 to +70°C -40 to +85°C	■ □	■ □	I
Storage temperature range: -40 to +85°C	■	■	
Supply voltage (V_{DD}): +3.3V (±5%) +2.5V (±5%)	■	■	
Supply current: 45mA max (40.0~170MHz) 50mA max (>170~250MHz)	■	■	
Output: Complementary LV-PECL	■	■	
Test load: R _T = 50Ω V _{TT} = V _{DD} -2.0V	■	■	
Logic levels: '0' level = V _{DD} -1.81 ~ V _{DD} -1.62 '1' level = V _{DD} -1.025 ~ V _{DD} -0.88	■	■	
Start up time: 10ms max	■	■	
Waveform symmetry: 45:55 max @ 50%V _{p,p}	■	■	
Rise / fall time: 0.4ns max (20 ~ 80%V _{p,p})	■	■	
Enable / disable function: Tristate (control via pad 1)	■	■	
Output enable / disable time: 10 ms / 200ns max	■	■	
Stand-by current: 10μA max	■	■	
Phase jitter RMS: 1ps max (0.3ps typ), 12kHz~20MHz	■	■	

■ Standard. □ Optional - Please specify required code(s) when ordering

* Frequency stability is inclusive of calibration @ 25°C, operating temperature range, supply voltage change and load change.

Ordering Information

Product name + variant + option codes (if any) + frequency
 eg: **GXO-E31L 156.250MHz** 3.3V, ±100ppm -10+70°C
GXO-E31J/BI 125.0MHz 2.5V, ±50ppm -40+85°C
 Option code X (eg GXO-E31L/X) denotes a custom spec.

Enable / Disable Function

Input (pad 1*)	Output 1 (pad 4)	Output 2 (pad 5)
Open '1' level (≥0.7V _{DD}) '0' level (≤0.3V _{DD})	Enabled Enabled High Impedance	Enabled Enabled High Impedance

* Enable / disable function can be on pad 2 on request.

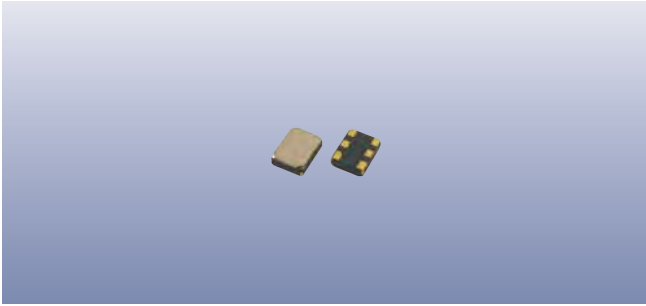

Construction

- ▮ Ceramic body with gold-plated pads
- ▮ Metal lid, seam sealed

Composition



This product is lead-free, and is fully compliant with the RoHS 2 directive 2011/65/EU



Packaging & Handling

Production quantities supplied on T&R, 2k pcs per reel.
Small quantities may be supplied on tape (no reel), or in bulk.



♦ Static sensitive product. Observe proper handling precautions

Marking

FREQUENCY DC
• PARTNO

- Pin 1
- Marking type: Laser
- DC = Date code in YM, eg "DE" = May 2014

	A	B	C	D	E	F	G	H	J	K	L	M
Y	1	2	3	4	5	6	7	8	9	0		
M	Jan	Feb	Mar	Apr	May	Jun	Jul	Aug	Sep	Oct	Nov	Dec

Tape & Reel Specification

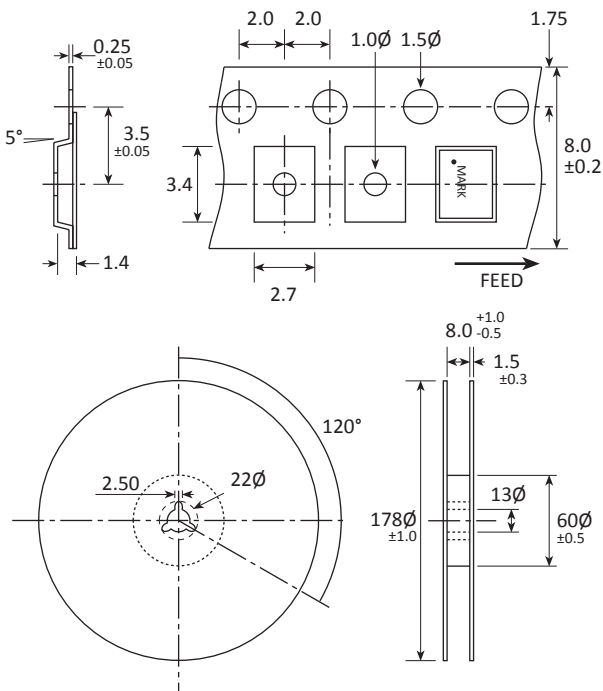

Not to scale. Dimensions in mm. Tolerances ±0.1mm unless otherwise stated.

Soldering Profile

