

## Features

- High current output up to 3A
- Low saturation voltage
- Complement to 2SB772SQ

## Applications

These devices are intended for use in audio frequency power amplifier and low speed switching applications

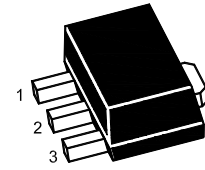

PIN1: Base PIN 2: Collector PIN 3: Emitter

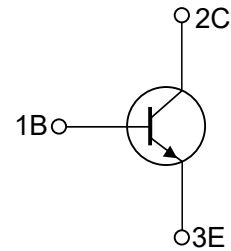

## Absolute Maximum Ratings (Ta=25°C unless otherwise specified)

Parameter	Symbol	Rating	Unit
Collector to Base Voltage	$V_{CBO}$	40	V
Collector to Emitter Voltage	$V_{CEO}$	30	V
Emitter to Base Voltage	$V_{EBO}$	5	V
Collector Current-Continuous	$I_C$	3	A
Peak Collector Current	$I_{CP}$	7	A
Total Power Dissipation	$P_D$	1	W
Total Power Dissipation	$P_D (T_c=25^\circ\text{C})$	10	W
Junction Temperature	$T_J$	150	°C
Storage Temperature Range	$T_{STG}$	-55~150	°C

Electrical Characteristics (Ta=25°C unless otherwise specified)

Parameter	Symbol	Min.	Typ.	Max.	Unit
DC Current Gain at V <sub>CE</sub> = 2 V, I <sub>C</sub> = 20 mA at V <sub>CE</sub> = 2 V, I <sub>C</sub> = 1 A					
	h <sub>FE</sub>	30	-	-	-
	h <sub>FE</sub>	60	-	120	-
	h <sub>FE</sub>	100	-	200	-
	h <sub>FE</sub>	160	-	320	-
Current Gain Group	R	60	-	120	-
	Q	100	-	200	-
	P	160	-	320	-
	E	200	-	400	-
Collector Base Cutoff Current at V <sub>CB</sub> = 30 V	I <sub>CBO</sub>	-	-	1	μA
Emitter Base Cutoff Current at V <sub>EB</sub> = 3 V	I <sub>EBO</sub>	-	-	1	μA
Collector Emitter Saturation Voltage at I <sub>C</sub> = 2 A, I <sub>B</sub> = 0.2 A	V <sub>CE(sat)</sub>	-	-	0.5	V
Base Emitter Saturation Voltage at I <sub>C</sub> = 2 A, I <sub>B</sub> = 0.2 A	V <sub>BE(sat)</sub>	-	-	2	V
Gain Bandwidth Product at V <sub>CE</sub> = 5 V, I <sub>C</sub> = 0.1 A	f <sub>T</sub>	-	90	-	MHz
Output Capacitance at V <sub>CB</sub> = 10 V, f = 1 MHz	C <sub>ob</sub>	-	45	-	pF

Typical Characteristic Curves

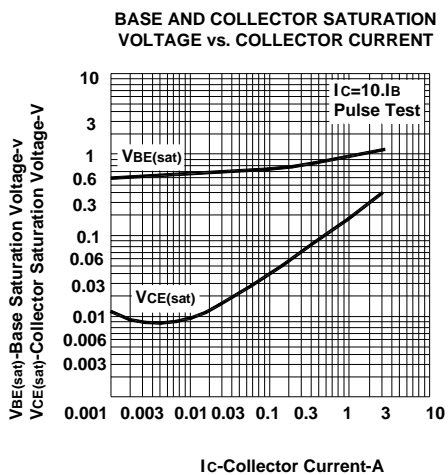
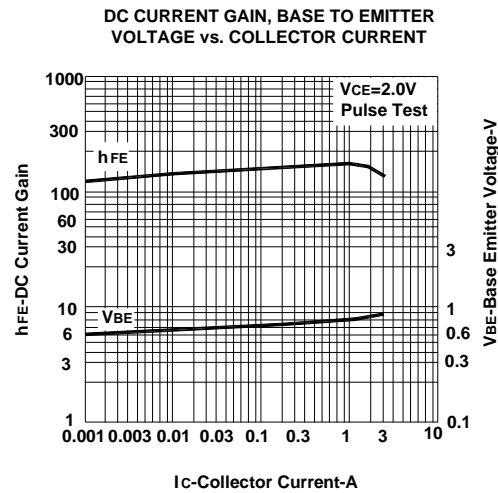
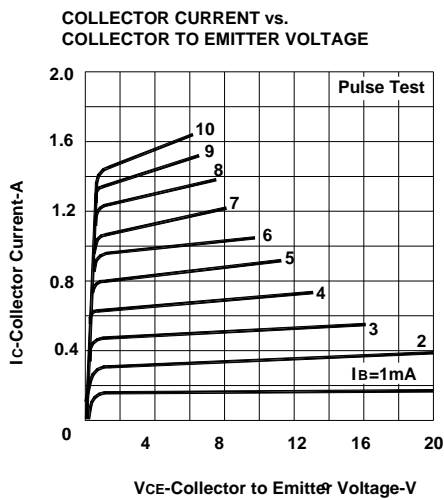

Package Outline

SOT-89

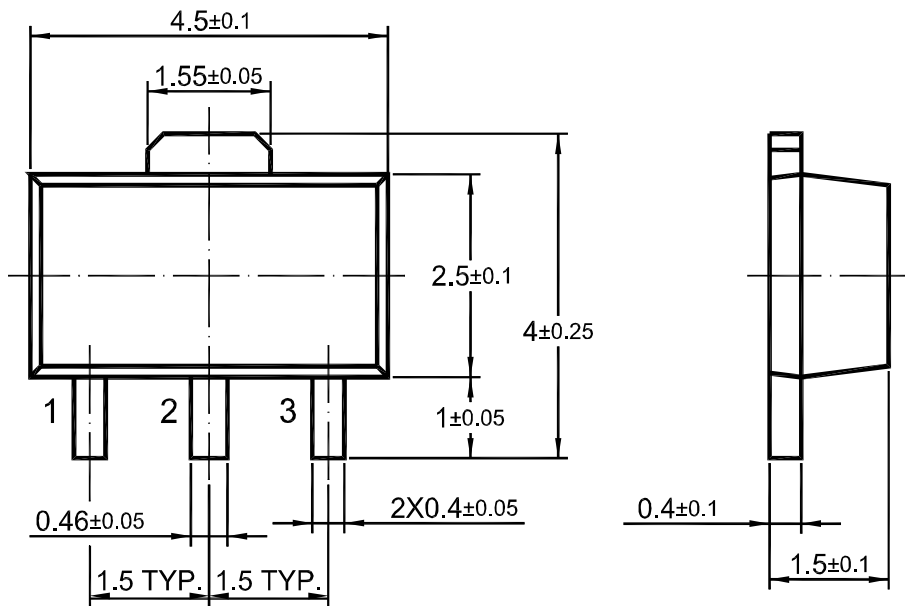

Ordering information

Device	Package	Shipping
D882	SOT-89	1000PCS