

PANEL MOUNTING
MAX. PANEL THICKNESS 8.0mm

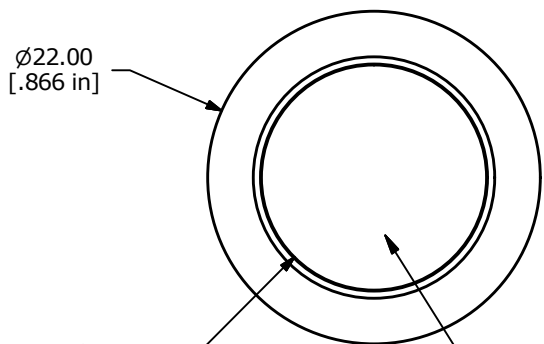

▲ RAISED FLAT ACTUATOR
POLISHED STAINLESS STEEL

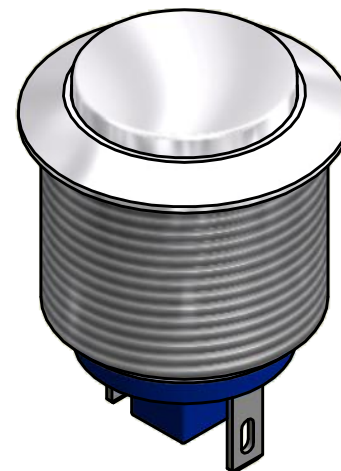

▲ SWITCH FUNCTION	
POS. 1	POS. 2
OFF	(ON)
OPEN	1-2

(ON) = MOMENTARY

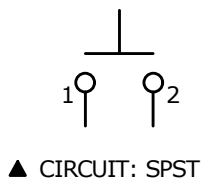

- NOTE:
1. ALL DIMENSIONS IN MM [INCH]
 2. GENERAL TOLERANCE: X.X = ± 0.4
X.XX = ± 0.25
 3. TERMINAL NOS. FOR REF. ONLY
 4. RATING: 2A @ 48VDC
 5. CONTACT RESISTANCE: 50mΩ MAX. @ 1A 12VDC
 6. INSULATION RESISTANCE: 1,000MΩ @ 500VDC
 7. DIELECTRIC STRENGTH: 2,000VAC MIN. FOR 1 MINUTE
 8. ELECTRICAL LIFE: 200,000 CYCLES
 - ▲ 9. CONTACT MATERIAL: GOLD
 10. OPERATING TEMPERATURE: -20°C TO 55°C
 11. INGRESS PROTECTION: IP65
 12. ▲ DENOTES CRITICAL PARAMETER
 13. 2002/95/EC (ROHS) COMPLIANT
 - ▲ 14. HARDWARE INCLUDED: HEX NUT AND O-RING (NOT SHOWN)

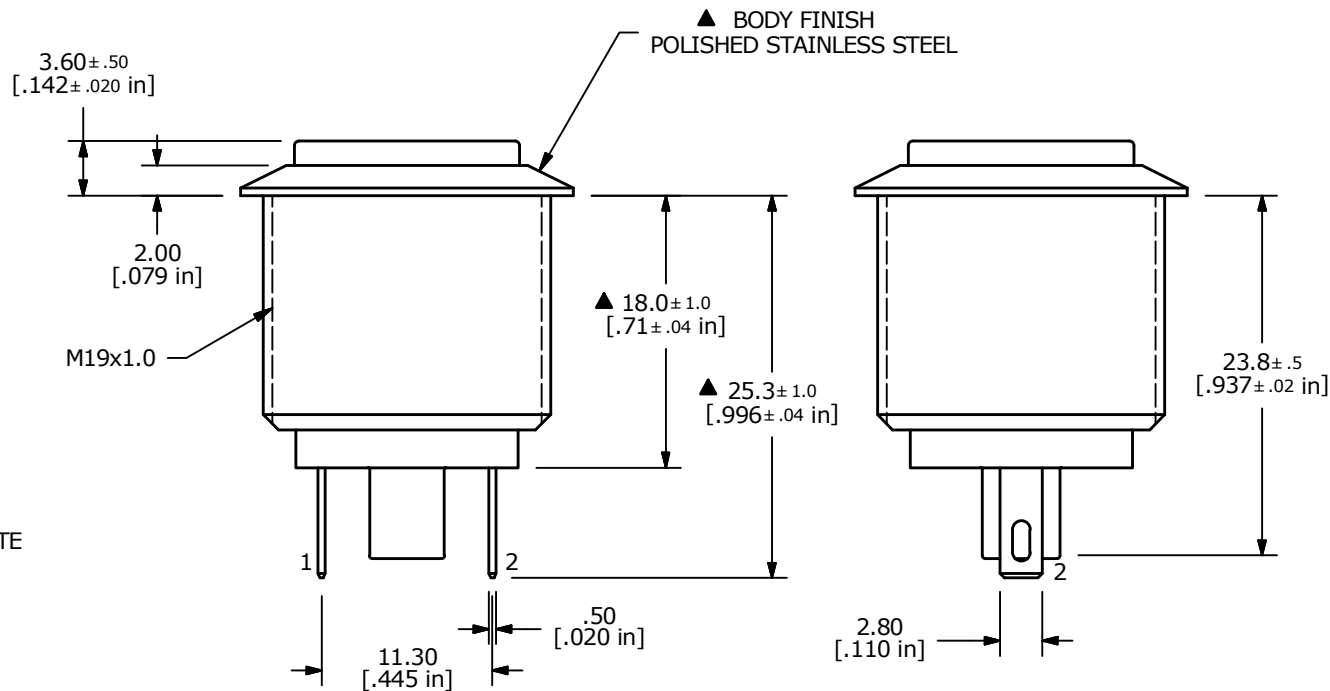

A	21927	RELEASE FOR PRODUCTION	7/24/15	MW
REV	PCR NO	DESCRIPTION	DATE	BY

TITLE PV1H240SSG				
SCALE 2:1	DATE 7/24/2015	DR MW	DWG 52-PV1H240SSG	REV A

THE INFORMATION CONTAINED IN THIS DOCUMENT IS PROPRIETARY TO E-SWITCH AND IS NOT TO BE COPIED OR TRANSFERRED