

PLEASE CHECK WWW.MOLEX.COM FOR LATEST PART INFORMATION

Part Number: [0876313048](#)
Status: **Active**
Overview: [extreme_powerplus_ssi](#)
Description: 6.35mm (.250") Pitch Power, 2.54mm (.100") Pitch Signal, EXTreme PowerPlus™ P-S-P Header, Through Hole, Right Angle, Long Contacts, 20 Circuits, Power Alpha 2, Signal 16, Power Beta 2, Recessed Signal Pin A2, D4, Lead-free

Documents:

[3D Model](#) [Product Specification PS-87631-006 \(PDF\)](#)
[Drawing \(PDF\)](#) [RoHS Certificate of Compliance \(PDF\)](#)

Agency Certification

CSA LR19980
TUV R50078473

General

Product Family PCB Headers
Series [87631](#)
Application Board-to-Board
Comments Long Contacts|Recessed Signal Pins: A2, D4
Overview [extreme_powerplus_ssi](#)
Product Name EXTreme PowerPlus™

Physical

Breakaway No
Circuits (Loaded) 16
Circuits Detail Power Alpha 2, Signal 16, Power Beta 2
Color - Resin Black
Durability (mating cycles max) 100
First Mate / Last Break Yes
Flammability 94V-0
Glow-Wire Compliant No
Guide to Mating Part Yes
Keying to Mating Part Yes
Lock to Mating Part Yes
Material - Metal Copper Alloy
Material - Plating Mating Gold
Material - Plating Termination Tin
Material - Resin High Temperature Thermoplastic
Number of Rows 4
Orientation Right Angle
PC Tail Length (in) 0.135 In
PC Tail Length (mm) 3.43 mm
PCB Locator Yes
PCB Retention Yes
PCB Thickness Recommended (in) 0.062 In
PCB Thickness Recommended (mm) 1.57 mm
Packaging Type Tray
Pitch - Mating Interface (in) 0.100 In, 0.250 In
Pitch - Mating Interface (mm) 2.54 mm, 6.35 mm
Plating min: Mating (µin) 30
Plating min: Mating (µm) 0.76
Plating min: Termination (µin) 100
Plating min: Termination (µm) 2.54
Polarized to Mating Part Yes
Polarized to PCB Yes

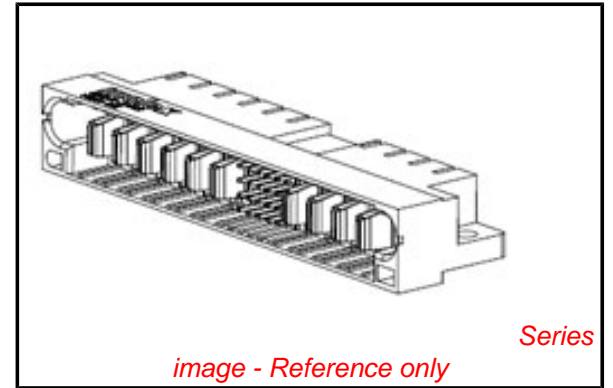

EU RoHS

ELV and RoHS Compliant
REACH SVHC
Not Reviewed
Halogen-Free Status
Not Reviewed

China RoHS



Need more information on product environmental compliance?

Email productcompliance@molex.com
For a multiple part number RoHS Certificate of Compliance, [click here](#)

Please visit the [Contact Us](#) section for any non-product compliance questions.

Search Parts in this Series

[87631Series](#)

Mates With

[87633](#) Vertical Press-Fit Receptacle. [87622](#) Vertical Through Hole Receptacle. [87632](#) Right Angle Through Hole Receptacle

Shrouded	Fully
Stackable	No
Temperature Range - Operating	-20°C to +105°C
Termination Interface: Style	Through Hole

Electrical

Current - Maximum per Contact	2.5A, 30A
Voltage - Maximum	250V DC

Solder Process Data

Duration at Max. Process Temperature (seconds)	10
Lead-free Process Capability	SMC & Wave Capable (TH only)
Max. Cycles at Max. Process Temperature	3
Process Temperature max. C	260

Material Info

Reference - Drawing Numbers

Application Specification	AS-87631-018
Product Specification	PS-87631-006
Sales Drawing	SD-87631-013

This document was generated on 05/25/2010

PLEASE CHECK WWW.MOLEX.COM FOR LATEST PART INFORMATION

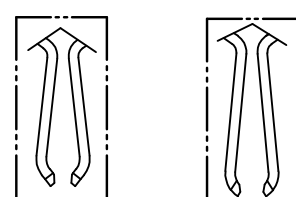
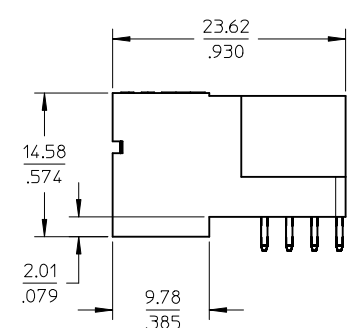
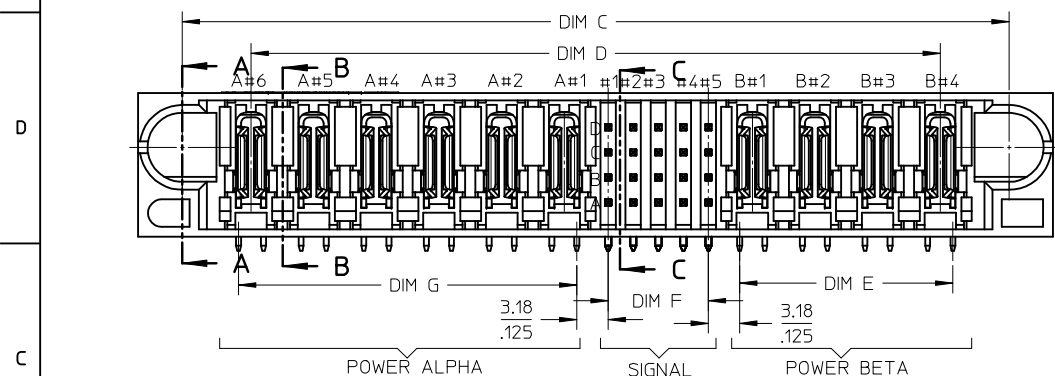
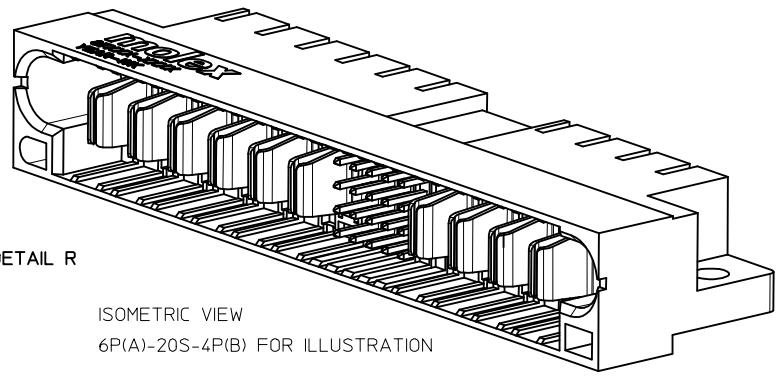
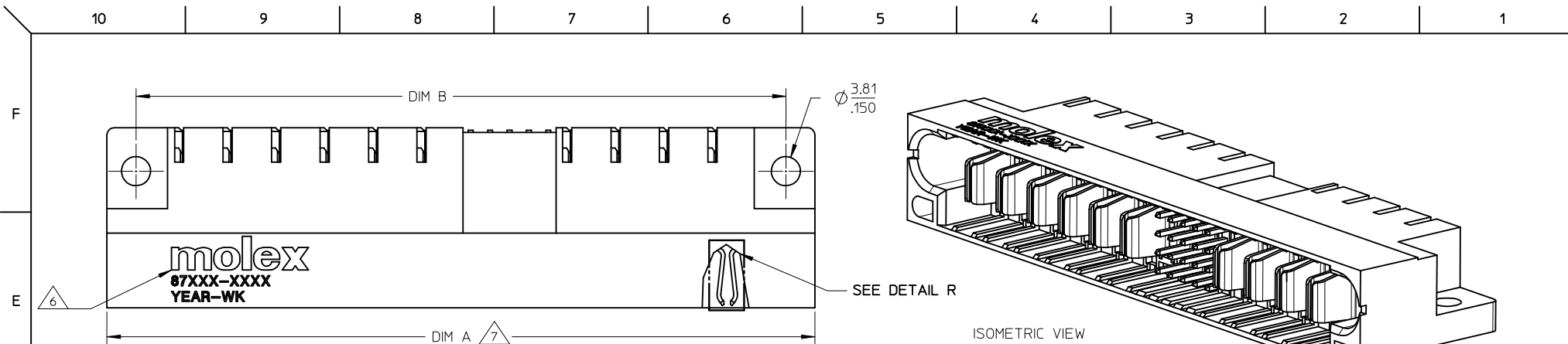

SHORT BLADE OPTION LONG BLADE OPTION
DETAIL R

(SEE TABLE FOR BLADE OPTION)

- NOTES:
- MATERIALS: HOUSING- LCP, GLASS FILLED, UL94V-0. COLOUR: BLACK
POWER PINS - COPPER ALLOY
SIGNAL PINS - COPPER ALLOY
 - FINISHES: POWER & SIGNAL PINS:
SELECTIVE GOLD IN CONTACT AREA.
THICKNESS= 0.76 MICROMETER/ 30 MICROINCH MINIMUM
SELECTIVE TIN IN THE PC TAIL AREA
THICKNESS= 2.54 MICROMETER/100 MICROINCH MINIMUM
1.27um NICKEL OVERALL.
 - PRODUCT SPECIFICATION: PS-87631-006.
 - SEE SHEET 2 FOR RECOMMENDED PCB LAYOUT AND THICKNESS.
5. COMPONENT STAY AWAY ZONE FROM CONNECTOR.
6. MANUFACTURER LOGO, PART NUMBER AND YEAR-WEEK CODE.
7. 6P ALPHA-20 SIGNAL-4P BETA CONFIGURATION IS SHOWN FOR ILLUSTRATION. P-S-P CONFIGURATION IS AVAILABLE UP TO 203mm/8 INCHES. PLEASE CONTACT MOLEX SALES PERSONNEL FOR OTHER CONFIGURATION AND OPTION NEEDED.

ADD P/N 87631-3050 EC NO: S2009-0538 DRWN:SKANG CHKD:ATSEE APPR:MLONG	2009/02/09 2009/02/09 2009/02/13	DESCRIPTION C13	QUALITY SYMBOLS	GENERAL TOLERANCES (UNLESS SPECIFIED)	DIMENSION STYLE	SCALE	DESIGN UNITS	THIRD ANGLE PROJECTION
			▽=0	mm INCH	MM/IN	NTS	METRIC	TITLE POWER CONNECTOR HEADER P(A)-S-P(B) CONFIG. R/A, T/H, SCREW-MOUNT
			▽=0	4 PLACES ± --- ± ---	BHLOW	DATE	2002/11/25	
			▽=0	3 PLACES ± --- ± .010	CHECKED BY	DATE	2002/11/26	
			2 PLACES ± 0.25 ± ---	PTL IM				
			1 PLACE ± --- ± ---	APPROVED BY	DATE			
			ANGULAR ± 3°	SKTOH	2002/11/27			
			DRAFT WHERE APPLICABLE MUST REMAIN WITHIN DIMENSIONS	MATERIAL NO.	SEE TABLE			
				SIZE	A3	MOLEX INCORPORATED SD-87631-013		SHEET NO. 1 OF 4
				THIS DRAWING CONTAINS INFORMATION THAT IS PROPRIETARY TO MOLEX INCORPORATED AND SHOULD NOT BE USED WITHOUT WRITTEN PERMISSION				

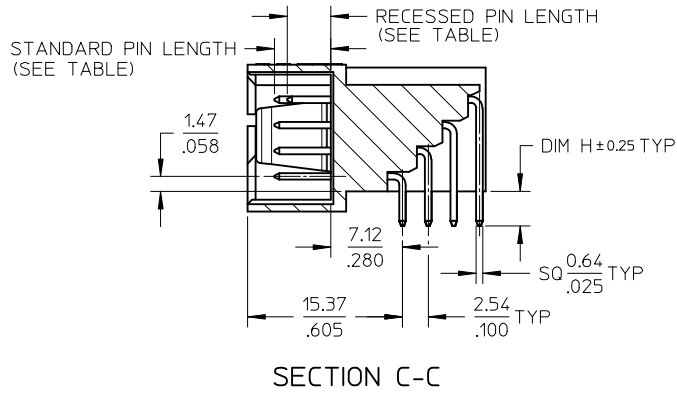

SECTION C-C

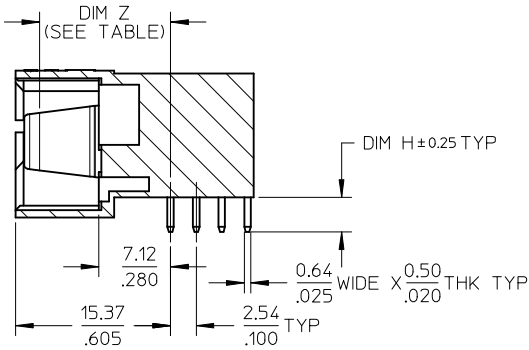

SECTION B-B

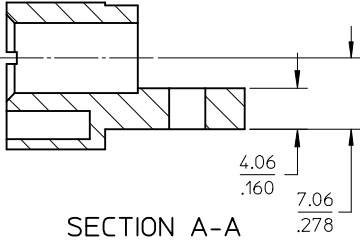

SECTION A-A

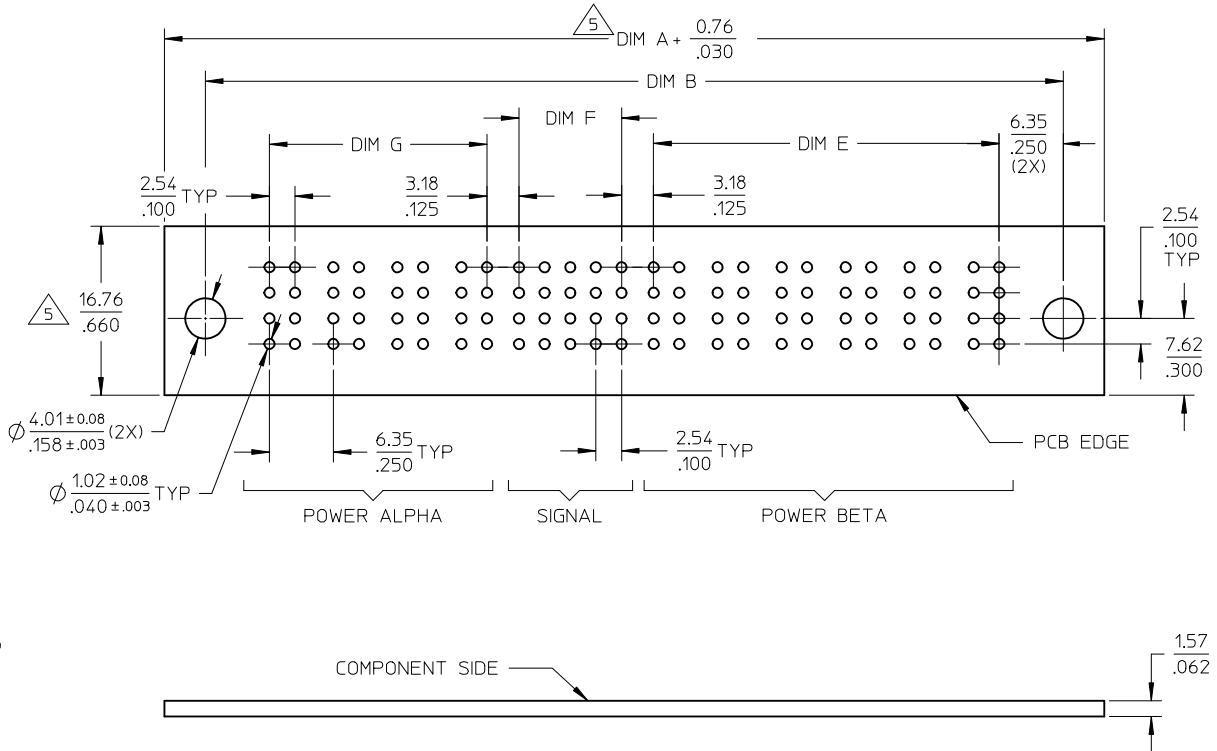

RECOMMENDED PCB LAYOUT

ADD P/N 87631-3050 EC NO: S2009-0538 DRWN:SKANG CHKD:ATSEE APPR:MLONG	2009/02/09 2009/02/09 2009/02/13	DESCRIPTION REV	QUALITY SYMBOLS	GENERAL TOLERANCES (UNLESS SPECIFIED)	DIMENSION STYLE	SCALE	DESIGN UNITS	THIRD ANGLE PROJECTION		
			$\nabla=0$ $\square=0$	mm INCH 4 PLACES ± --- ± --- 3 PLACES ± --- ± .010 2 PLACES ± 0.25 ± --- 1 PLACE ± --- ± --- ANGULAR ± 3 °	MM/IN	NTS	METRIC	DRAWN BY: BHLW DATE: 2002/11/25 CHECKED BY: PTLIM DATE: 2002/11/26 APPROVED BY: SKTOH DATE: 2002/11/27	TITLE	POWER CONNECTOR HEADER P(A)-S-P(B) CONFIG. R/A, T/H, SCREW-MOUNT MOLEX INCORPORATED DOCUMENT NO. SD-87631-013
			DRAFT WHERE APPLICABLE MUST REMAIN WITHIN DIMENSIONS	SEE TABLE	SIZE	THIS DRAWING CONTAINS INFORMATION THAT IS PROPRIETARY TO MOLEX INCORPORATED AND SHOULD NOT BE USED WITHOUT WRITTEN PERMISSION		SHEET NO.		
			C13	A3	2 OF 4					

10		9		8		7		6		5		4		3		2		1	
PART NUMBER	P-S-P CONFIGURATION			DIM A	DIM B	DIM C	DIM D	DIM E	DIM F	DIM G	DIM H	POWER BLADE OPTIONS		STANDARD SIGNAL		RECESSED SIGNAL PIN		VOID SIGNAL LOCATION	PACKAGING
	POWER ALPHA	SIGNAL	POWER BETA									TYPE	DIM Z ±0.13/.005	PIN LENGTH	LENGTH	LOCATION			
87631-3000	3	24	5	82.54 3.250	74.93 2.950	73.65 2.900	59.69 2.350	27.94 1.100	12.70 .500	15.24 .600	3.43 .135	SHORT CONTACT	13.32 / .524	5.59 / .220	4.32/.170		NIL		TRAY
87631-3001	6	20	4	92.71 3.350	85.10 3.350	83.82 3.300	69.86 2.750	21.59 .850	10.16 .400	34.29 1.350							C2		TRAY
87631-3002	4	24	4	82.54 3.250	74.93 2.950	73.65 2.900	59.69 2.350	21.59 .850	12.70 .500	21.59 .850							A1		TRAY
87631-3003	3	24	3	69.84 2.750	62.23 2.450	60.95 2.400	46.99 1.850	15.24 .600	12.70 .500	15.24 .600							NIL		TRAY
87631-3004	2	24	2	57.15 2.250	49.53 1.950	48.26 1.900	34.29 1.350	8.89 .350	12.70 .500	8.89 .350							NIL		TRAY
87631-3006	2	32	2	62.23 2.450	54.61 2.150	53.34 2.100	39.37 1.550	8.89 .350	17.78 .700	8.89 .350							NIL		TRAY
87631-3008	2	24	2	57.15 2.250	49.53 1.950	48.26 1.900	34.29 1.350	8.89 .350	12.70 .500	8.89 .350							B4		TRAY
87631-3009	2	24	4	69.84 2.750	62.23 2.450	60.95 2.400	46.99 1.850	21.59 .850	12.70 .500	8.89 .350							B4		TRAY
87631-3010	4	24	6	95.24 3.750	87.63 3.450	86.35 3.400	72.39 2.850	34.29 1.350	12.70 .500	21.59 .850							B4		TRAY
87631-3011	6	24	5	101.59 4.000	93.98 3.700	92.70 3.650	78.74 3.100	27.94 1.100	12.70 .500	34.29 1.350							A3, B6, C3, D5		TRAY
87631-3013	4	24	2	69.84 2.750	62.23 2.450	60.95 2.400	46.99 1.850	8.89 .350	12.70 .500	21.59 .850							C1		TRAY
87631-3020	1	16	1	39.37 1.550	31.75 1.250	30.48 1.200	16.51 .650	2.54 .100	7.62 .300	2.54 .100		LONG CONTACT	14.12 / .556	6.86 / .270	5.59/.220		B1	NIL	TRAY
87631-3015	4	20	4	80.00 3.150	72.39 2.850	71.11 2.800	57.15 2.250	21.59 .850	10.16 .400	21.59 .850							B3		TRAY
87631-3021	6	24	5	101.59 4.000	93.98 3.700	92.70 3.650	78.74 3.100	27.94 1.100	12.70 .500	34.29 1.350							A3, B6, C3, D5		TRAY
87631-3022	2	12	2	49.53 1.950	41.91 1.650	40.64 1.600	26.67 1.050	8.89 .350	5.08 .200	8.89 .350							B2 C3		TRAY
87631-3023	2	12	2	49.53 1.950	41.91 1.650	40.64 1.600	26.67 1.050	8.89 .350	5.08 .200	8.89 .350	2.34 .092						B1 C3		TRAY
87631-3024	1	12	1	36.83 1.450	29.21 1.150	27.94 1.100	13.97 .550	2.54 .100	5.08 .200	2.54 .100	3.43 .135						NIL		TRAY
87631-3028	2	24	2	57.15 2.250	49.53 1.950	48.26 1.900	34.29 1.350	8.89 .350	12.70 .500	8.89 .350	3.43 .135						C6		TRAY
87631-3031	4	24	2	69.84 2.750	62.23 2.450	60.95 2.400	46.99 1.850	8.89 .350	12.70 .500	21.59 .850	3.43 .135						C1		TRAY
87631-3037	3	24	3	69.84 2.750	62.23 2.450	60.95 2.400	46.99 1.850	15.24 .600	12.70 .500	15.24 .600	3.43 .135						ALL EXCEPT A6,B1,C1		TRAY
87631-3038	4	16	2	64.77 2.550	57.16 2.250	55.88 2.200	41.92 1.650	8.89 .350	7.62 .300	21.59 .850	3.43 .135						A1,A2,A4,B1,B3 C2,C4,D1,D2,D3,D4		TRAY
87631-3041	2	24	2	57.15 2.250	49.53 1.950	48.26 1.900	34.29 1.350	8.89 .350	12.70 .500	8.89 .350	3.43 .135						C3		TRAY

A ADD P/N 87631-3050 EC NO: S2009-0538 DRWN:SKANG CHYD:ATSEE APPR:MLONG 2009/02/09 2009/02/09 2009/02/13 DESCRIPTION REV C13	QUALITY SYMBOLS ▽=0 ◻=0	GENERAL TOLERANCES (UNLESS SPECIFIED) mm INCH 4 PLACES ± --- ± --- 3 PLACES ± --- ± .010 2 PLACES ± 0.25 ± --- 1 PLACE ± --- ± --- ANGULAR ± 3 °	DIMENSION STYLE MM/IN DRAWN BY BHLW DATE 2002/11/25 CHECKED BY PTL IM DATE 2002/11/26 APPROVED BY SKTOH DATE 2002/11/27 MATERIAL NO. SEE TABLE DRAFT WHERE APPLICABLE MUST REMAIN WITHIN DIMENSIONS	SCALE NTS DESIGN UNITS METRIC THIRD ANGLE PROJECTION	TITLE POWER CONNECTOR HEADER P(A)-S-P(B) CONFIG. R/A, T/H, SCREW-MOUNT MOLEX INCORPORATED DOCUMENT NO. SD-87631-013 SHEET NO. 3 OF 4
	THIS DRAWING CONTAINS INFORMATION THAT IS PROPRIETARY TO MOLEX INCORPORATED AND SHOULD NOT BE USED WITHOUT WRITTEN PERMISSION				
	SIZE A3				
	THIS DRAWING CONTAINS INFORMATION THAT IS PROPRIETARY TO MOLEX INCORPORATED AND SHOULD NOT BE USED WITHOUT WRITTEN PERMISSION				

PART NUMBER	P-S-P CONFIGURATION			DIM A	DIM B	DIM C	DIM D	DIM E	DIM F	DIM G	DIM H	POWER BLADE OPTIONS		STANDARD SIGNAL PIN LENGTH	RECESSED SIGNAL PIN		VOID SIGNAL LOCATION	PACKAGING
	POWER ALPHA	SIGNAL	POWER BETA									TYPE	DIM Z ± 0.13/.005		LENGTH	LOCATION		
87631-3042	2	16	2	52.07 2.050	44.45 1.750	43.18 1.700	29.21 1.150	8.89 .350	7.62 .300	8.89 .350	3.43 .135	LONG CONTACT	14.12 / .556	6.86 / .270	5.59/.220	B3,C4	NIL	TRAY
87631-3043	7	28	7	123.19 4.850	115.57 4.550	114.30 4.500	100.33 3.950	40.64 1.600	15.24 .600	40.64 1.600	3.43 .135	LONG CONTACT	14.12 / .556	6.86 / .270	5.59/.220	B4,C4		TRAY
87631-3044	7	28	7	123.19 4.850	115.57 4.550	114.30 4.500	100.33 3.950	40.64 1.600	15.24 .600	40.64 1.600	3.43 .135	LONG CONTACT	14.12 / .556	6.86 / .270	5.59/.220	NIL		TRAY
87631-3045	6	28	4	97.79 3.850	90.17 3.550	88.90 3.500	74.93 2.950	21.59 .850	15.24 .600	34.29 1.350	3.43 .135	LONG CONTACT	14.12 / .556	6.86 / .270	5.59/.220	A1	A7,B7,C7,D7	TRAY
87631-3046	6	24	4	95.25 3.750	87.63 3.450	86.36 3.400	72.39 2.850	21.59 .850	12.70 .500	34.29 1.350	3.43 .135	LONG CONTACT	14.12 / .556	6.86 / .270	5.59/.220	A1	NIL	TRAY
87631-3047	2	24	2	57.15 2.250	49.53 1.950	48.26 1.900	34.29 1.350	8.89 .350	12.70 .500	8.89 .350	3.43 .135	LONG CONTACT	14.12 / .556	6.86 / .270	5.59/.220	A6,B6,C6,D6		TRAY
87631-3048	2	16	2	52.07 2.050	44.45 1.750	43.18 1.700	29.21 1.150	8.89 .350	7.62 .300	8.89 .350	3.43 .135	LONG CONTACT	14.12 / .556	6.86 / .270	5.59/.220	A2,D4	A1,B2,C2,D1	TRAY
87631-3049	4	24	4	82.54 3.250	74.93 2.950	73.65 2.900	59.69 2.350	21.59 .850	12.70 .500	21.59 .850	3.43 .135	LONG CONTACT	14.12 / .556	6.86 / .270	5.59/.220	A6	NIL	TRAY
87631-3050	2	24	2	57.15 2.250	49.53 1.950	48.26 1.900	34.29 1.350	8.89 .350	12.70 .500	8.89 .350	3.43 .135	LONG CONTACT	14.12 / .556	6.86 / .270	5.59/.220	A5	NIL	TRAY

ADD P/N 87631-3050 EC NO: S2009-0538 DRWN:SKANG CHKD:ATSEE APPR:MLONG	2009/02/09 2009/02/09 2009/02/13	DESCRIPTION REV	QUALITY SYMBOLS	GENERAL TOLERANCES (UNLESS SPECIFIED)	DIMENSION STYLE	SCALE	DESIGN UNITS	THIRD ANGLE PROJECTION
			$\nabla = 0$ $\square = 0$	mm INCH	MM/IN	NTS	METRIC	\odot \square
			4 PLACES ± --- ± --- 3 PLACES ± --- ± .010 2 PLACES ± 0.25 ± --- 1 PLACE ± --- ± --- ANGULAR ± 3 °	DRAWN BY: BHLW DATE: 2002/11/25 CHECKED BY: PTLIM DATE: 2002/11/26 APPROVED BY: SKTOH DATE: 2002/11/27	TITLE: POWER CONNECTOR HEADER P(A)-S-P(B) CONFIG. R/A, T/H, SCREW-MOUNT			MOLEX INCORPORATED
			DRAFT WHERE APPLICABLE MUST REMAIN WITHIN DIMENSIONS	MATERIAL NO. DOCUMENT NO.	SEE TABLE SD-87631-013	SHEET NO. 4 OF 4		
SIZE A3		THIS DRAWING CONTAINS INFORMATION THAT IS PROPRIETARY TO MOLEX INCORPORATED AND SHOULD NOT BE USED WITHOUT WRITTEN PERMISSION						