

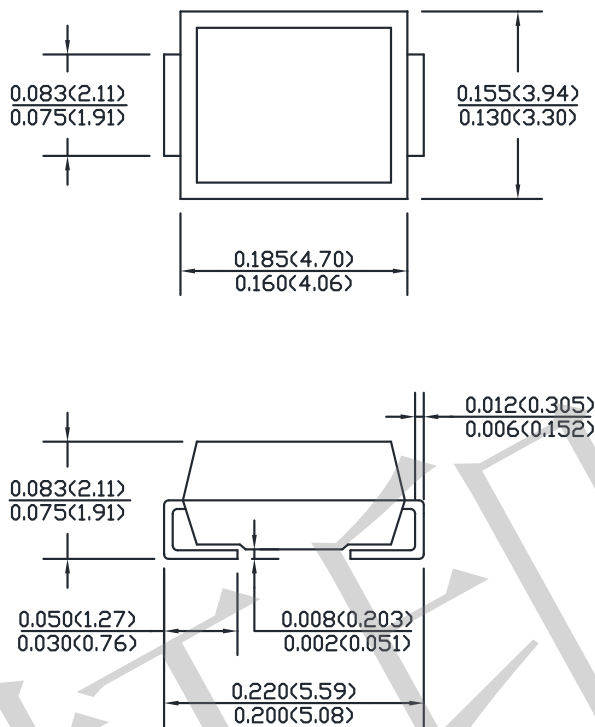

Transient Voltage Suppressor

Breakdown Voltage 3.3 to 30 Volts

CASE: SMB (DO214AA)



Dimensions in inches and (millimeters)

Features

- Extensive Voltages selection from 3.3 to 30V
- Silicon 2.0 Watt Zener Diodes
- Ideal for high-density and low-profile mounting
- Regulates voltage over a broad operating current and temperature range

Application

- Use in sensitive electronics protection against voltage transients induced by inductive load switching and lighting on ICs, MOSFE, signal lines of sensor units for consumer, computer, industrial, automotive and telecommunication

Mechanical Data

- **Case:** Void-free transfer molded thermosetting epoxy body meeting UL94V-O
- **Terminals:** Tin-Lead or ROHS Compliant annealed matte-Tin plating readily solderable per MIL-STD-750, Method 2026
- **Marking:** Body marked with part number
- **Polarity:** Cathode indicated by band
- **Weight:** 0.093g (Approximately)

Maximum Ratings and Electrical Characteristics @ 25°C unless otherwise specified

Symbol	Conditions	Value	Unit
P _{M(AV)}	Steady state power at T _L ≤ 80°C 0.375" (10mm) from body	2.0	W
	Steady state power at T _A =25°C when mounted on FR4 PC described for thermal resistance (also see Fig.1)	1.25	W
V _F	Maximum instantaneous forward voltage at 200mA	1.2	V
R _{θJL}	Thermal resistance junction to lead	35	°C/W
R _{θJA}	Thermal resistance junction to ambient	100	°C/W
T _J , T _{STG}	Operating and Storage Temperature	-65 to +150	°C

Electrical Characteristics @ 25°C (Unless Otherwise Noted)

Microsemi Part Number	Zener Voltage $V_Z @ I_{ZT}$	Test Current	Dynamic Impedance	Knee Impedance	Knee Current	Reverse Current $I_R @ V_R$		MAX. DC current
	V_Z (V)	I_{ZT} (mA)	Z_{ZT} (OHMS)	Z_{ZK} (OHMS)	I_{ZK} (mA)	I_R (μ A)	V_R (V)	I_{ZM} (mA)
SMBJ5913	3.3	113.6	10.0	500	1.00	100	1.0	606
SMBJ5914	3.6	104.2	9.0	500	1.00	75	1.0	554
SMBJ5915	3.9	96.1	7.5	500	1.00	25	1.0	512
SMBJ5916	4.3	87.2	6.0	500	1.00	5.0	1.0	464
SMBJ5917	4.7	79.8	5.0	500	1.00	5.0	1.5	425
SMBJ5918	5.1	73.5	4.0	350	1.00	5.0	2.0	392
SMBJ5919	5.6	66.9	2.0	250	1.00	5.0	3.0	356
SMBJ5920	6.2	60.5	2.0	200	1.00	5.0	4.0	321
SMBJ5921	6.8	55.1	2.5	200	1.00	5.0	5.2	293
SMBJ5922	7.5	50.0	3.0	400	0.50	5.0	6.0	266
SMBJ5923	8.2	45.7	3.5	400	0.50	5.0	6.5	242
SMBJ5924	9.1	41.2	4.0	500	0.50	5.0	7.0	218
SMBJ5925	10.0	37.5	4.5	500	0.25	5.0	8.0	200
SMBJ5926	11.0	34.1	5.5	550	0.25	1.0	8.4	181
SMBJ5927	12.0	31.2	6.5	550	0.25	1.0	9.1	166
SMBJ5928	13.0	28.8	7.0	550	0.25	1.0	9.9	153
SMBJ5929	15.0	25.0	9.0	600	0.25	1.0	11.4	133
SMBJ5930	16.0	23.4	10.0	600	0.25	1.0	12.2	122
SMBJ5931	18.0	20.8	12.0	650	0.25	1.0	13.7	110
SMBJ5932	20.0	18.7	14.0	650	0.25	1.0	15.2	100
SMBJ5933	22.0	17.0	17.5	650	0.25	1.0	16.7	90
SMBJ5934	24.0	15.6	19.0	700	0.25	1.0	18.2	82
SMBJ5935	27.0	13.9	23.0	700	0.25	1.0	20.6	73
SMBJ5936	30.0	12.5	28.0	750	0.25	1.0	22.8	66

Note:

1. No suffix indicates a $\pm 20\%$ tolerance on nominal V_Z . Suffix A denotes a $\pm 10\%$ tolerance, B denotes a $\pm 5\%$ tolerance, C denotes a $\pm 2\%$ tolerance, and D denotes a $\pm 10\%$ tolerance.
2. Zener voltage (V_Z) is measured at $T_L=30^\circ\text{C}$ and 20seconds after application of dc current.
3. The Zener impedance is derived from the 1HZ ac voltage resulting from an ac current modulation having an rms value equal to 10% of the dc zener current (I_{ZT} or I_{ZK}) superimposed on I_{ZT} or I_{ZK} .
4. The maximum dc current (I_{ZM}) is based only on the maximum power of 2.0watts at $T_L \leq 80^\circ\text{C}$. These values must be reduced by 37.5% (1.25W) when mounted on PC boards as described in Maximum Ratings.

Characteristic Curve

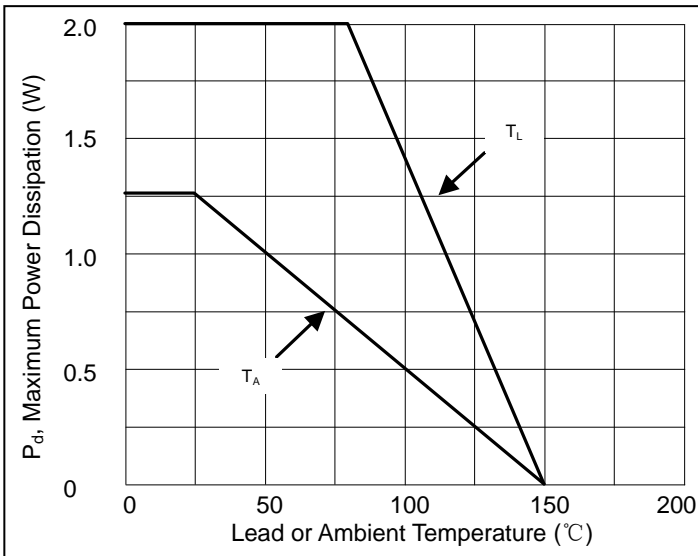

Fig.1 Power Derating Curve

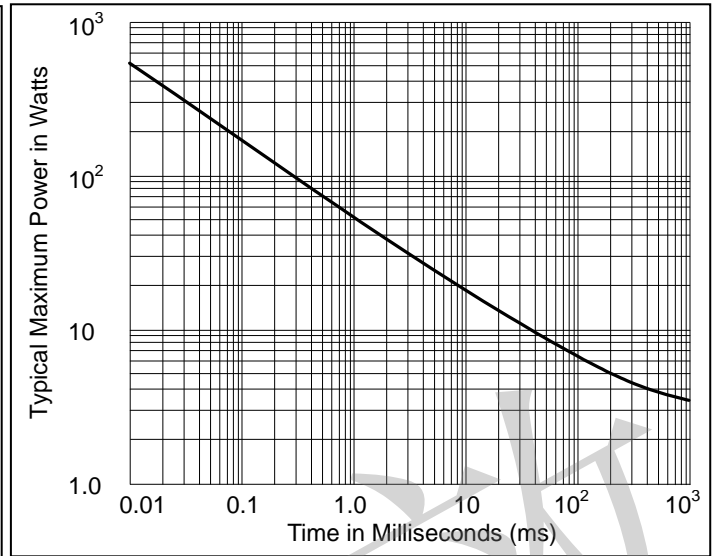

Fig.2 Transient Surge Capability Square-Wave Pulse Width (non-Repetitive) in milliseconds

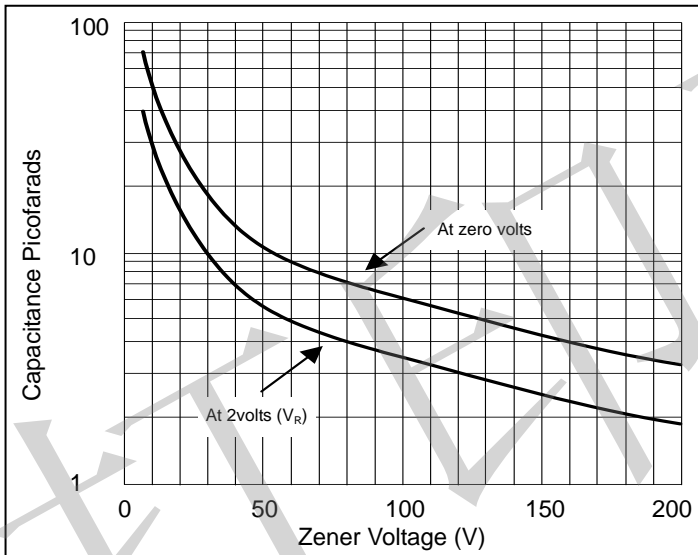

Fig.3 Capacitance vs. Zener Voltage