

240-790-070
Series 79 Filtered Cable Plug
with Solder Cup Termination

How To Order Filter Series 79 Connectors

Sample Part Number	240-790-070	S	H-66	ME	E	P	D	S
Series	240-790-070							
Contact Type	S - Socket Contacts							
Insert Arrangement	(See Table I)							
Shell Material/Finish	Aluminum Shell ME - Electroless Nickel MT - Nickel-PTFE E - Chem Film Z2 - Gold UC - Zinc Cobalt with Black Chromate J - Cadmium with Yellow Chromate NF - Cad/O.D. over Electroless Nickel							
EMI Spring	E - With EMI Spring N - No EMI Spring							
Filter Type	C - C Filter P - Pi Filter							
Filter Class	X, Y, Z, A, B, C, D, E, F, G, J (See Table II)							
Mating Hardware Options	L - Low-Profile Captive Jackscrew K - Extended Captive Jackscrew N - No Mating Hardware P - Jackposts S - Low-Profile Captive Screwlock T - Extended Captive Screwlock (See Table III)							

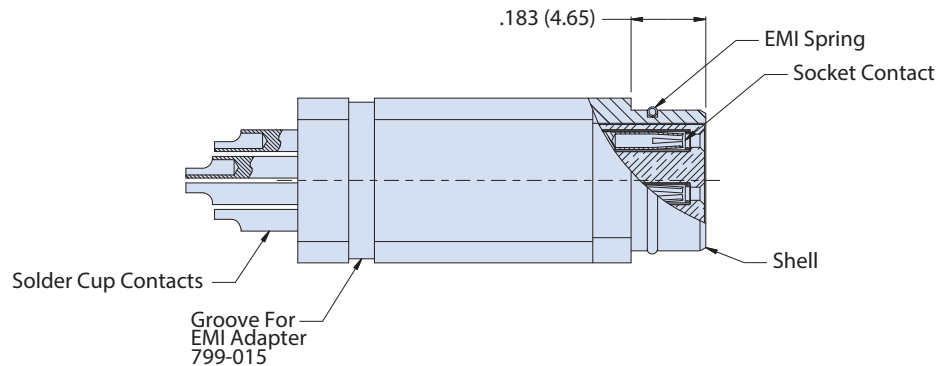
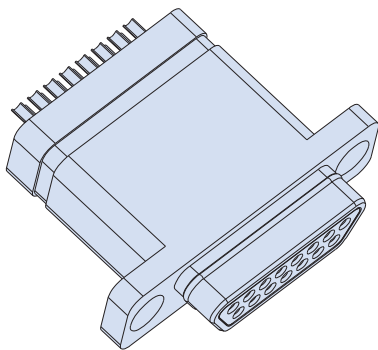

Notes

1. Assembly to be identified with Glenair's name, part number, and date code, space permitting
2. Ground spring is not compatible with Zinc Cobalt or Cadmium platings. Ground spring is only available with Nickel, Teflon Nickel, Gold, or Chem Film plating on the shell.
3. EMI Filtered plug connector designed to meet requirements of MIL-STD-2120 and Glenair Series 79 specifications. Unless otherwise specified herein, refer to Glenair specification 799-008 for additional performance characteristics.
4. All contacts to have identical filter value. Other filter arrangements available, contact factory
5. Dielectric Withstanding Voltage: 500 VDC (Filter Class X, Y, Z are 250 VDC)
6. Insulation Resistance: 5,000 megohms @ 200 VDC

7. Current Carrying Capacity

- 23 Gage - 5 Amps max. for all layouts
- 16 Gage - 7.5 Amps max. for combo layouts / 13 Amps max. for all-power layouts
- 12 Gage - 13 Amps max. for combo layouts / 23 Amps max. for all-power layouts

8. Other filter styles (C-L, L-C, Unbalanced Pi, Multi-Stage, Multi-Value) are available. Please consult factory with your requirements.

Materials/Finishes:

- Insulators - High Grade Rigid Dielectric / N.A.
- Contacts - Copper Alloy / 50 microinches Gold over Nickel
- Mating Hardware - 300 Series Stainless Steel / Passivated

Dimensions in inches (millimeters) and are subject to change without notice.

240-790-070
 Series 79 Filtered Cable Plug
 with Solder Cup Termination



Table I: Contact Arrangements

Layout	Contact Quantity			Face View
	#23	#16	#12	
A-5	5			
B-2P2		2		
B-9	9			
C-13	13			
D-15	15			
D-3P3		3		
D-7P2	5	2		
E-11P2	9	2		
E-19	19			
E-7P3	4	3		
F-15P2	13	2		
F-23	23			
F-5P5		5		
G-33	33			
H-10P4	6		4	
H-29P7	22	7		
H-36P2	34		2	
H-54P2	52	2		
H-5P5			5	
H-66	66			
J-17P4	13	4		
J-25P2	23	2		
J-33	33			
J-7P7		7		
K-27P4	23	4		
K-35P2	33	2		
K-43	43			
K-9P9		9		
L-6P6			6	
L-78	78			
M-102	102			

Table II: Capacitor Array Code / Capacitance Range

Class	Pi - Circuit (pF)	C - Circuit (pF)
X*†	160,000 - 240,000	80,000 - 120,000
Y*	80,000 - 120,000	40,000 - 60,000
Z*	60,000 - 90,000	30,000 - 45,000
A	38,000 - 56,000	19,000 - 28,000
B	32,000 - 45,000	16,000 - 22,500
C	18,000 - 33,000	9,000 - 16,500
D	8,000 - 12,000	4,000 - 6,000
E	3,300 - 5,000	1,650 - 2,500
F	800 - 1,300	400 - 650
G	400 - 600	200 - 300
J	70-120	35-60

* Filter Classes X, Y and Z are 250 VDC.
 All others are 500 VDC
 † Class X filters not available for insert arrangements with 3 or more rows of contacts

Table III: Jackscrew, Screwlock, and Jackpost Options

L	K	S	T	P
Low-Profile Captivated Jackscrew, Allen Head	Extended Captivated Jackscrew, Knurled Slot Head	Low-Profile Captivated Screwlock, Allen Head	Extended Captivated Screwlock, Knurled Slot Head	Jackpost with Nut and Split Washer
Notes: 1. Thread size is #2-56 for shell sizes A, B, C, D, E, F, G, J, K; #4-40 for shell sizes H and L; #6-32 for shell size M. 2. Screwlocks allow full mating of the connectors before the screws are fastened. Jackscrews must be tightened to mate the connectors.				

Dimensions in inches (millimeters) and are subject to change without notice.





240-790-070S SHELL SIZE A, B, C, D, E, F, J AND K DIMENSIONS

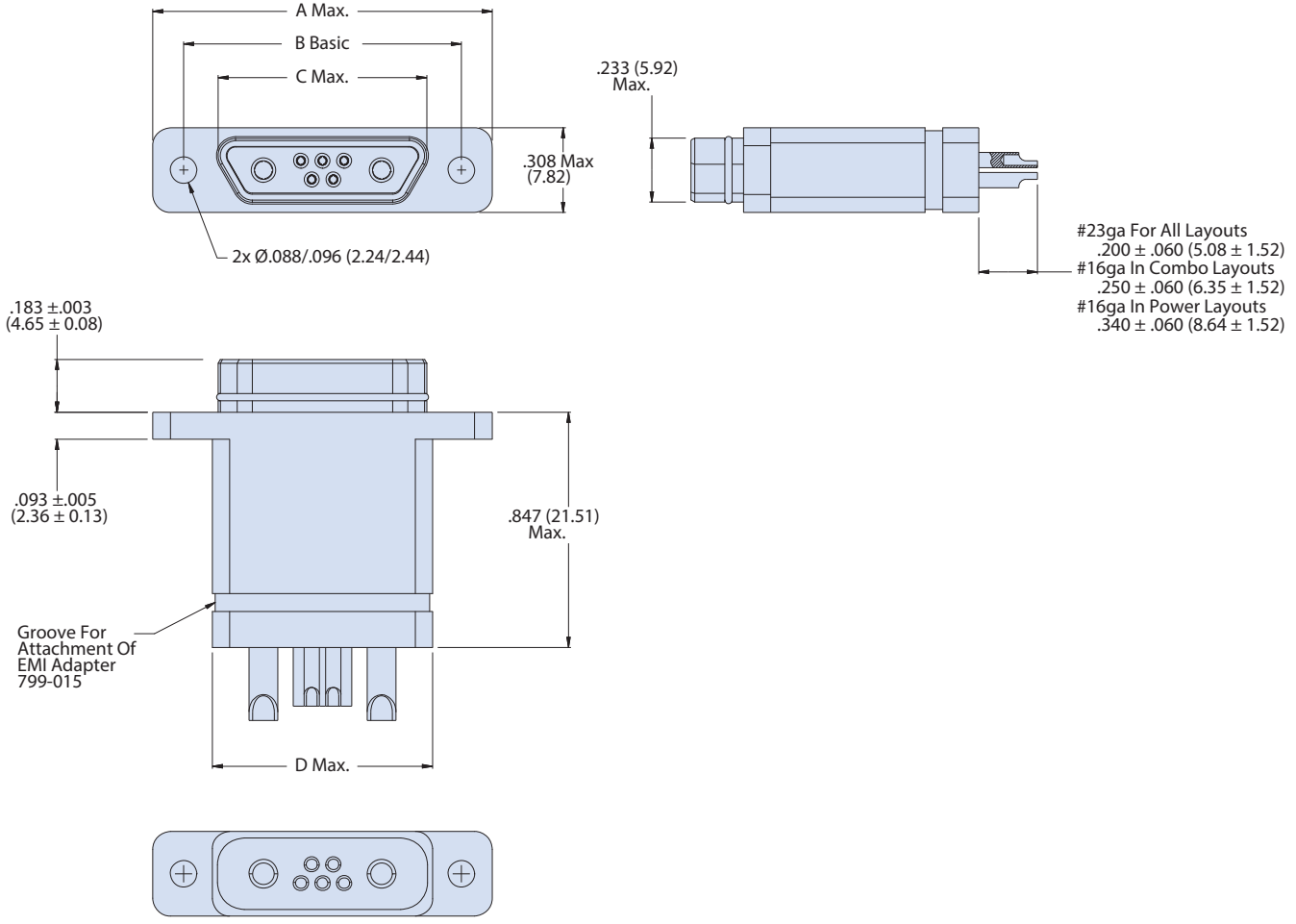

Shell Sizes A,B,C,D,E,F,J,K

790-070S Dimensions for Size A-F, J and K								
Shell Size	A Max.		B Basic		C Max		D Max	
	In.	mm.	In.	mm.	In.	mm.	In.	mm.
A	.785	19.94	.565	14.35	.335	8.51	.390	9.91
B	.935	23.75	.715	18.16	.485	12.32	.540	13.72
C	1.085	27.56	.865	21.97	.635	16.13	.690	17.53
D	1.185	30.10	.965	24.51	.735	18.67	.790	20.07
E	1.335	33.91	1.115	28.32	.885	22.48	.940	23.88
F	1.485	37.72	1.265	32.13	1.035	26.29	1.090	27.69
J	1.845	46.86	1.615	41.02	1.390	35.31	1.450	36.83
K	2.240	56.90	2.015	51.18	1.795	45.59	1.840	46.74

Dimensions in inches (millimeters) and are subject to change without notice.

240-790-070
 Series 79 Filtered Cable Plug
 with Solder Cup Termination



240-790-070S SHELL SIZE G DIMENSIONS

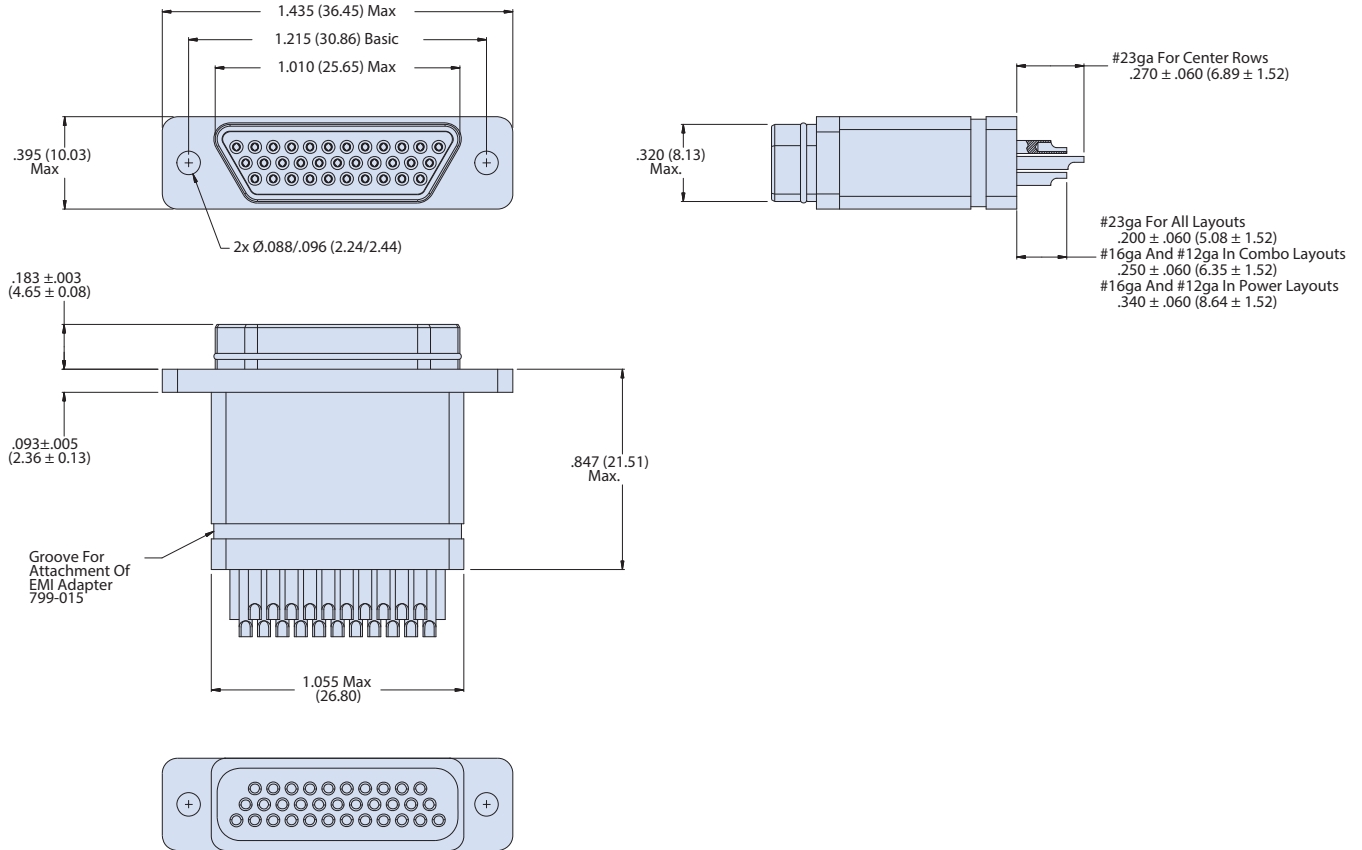

Shell Size G

Dimensions in inches (millimeters) and are subject to change without notice.

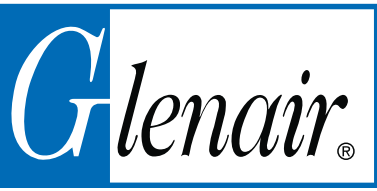

240-790-070S SHELL SIZE H AND L DIMENSIONS

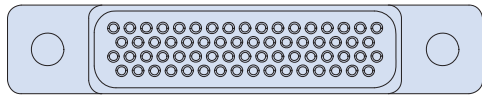
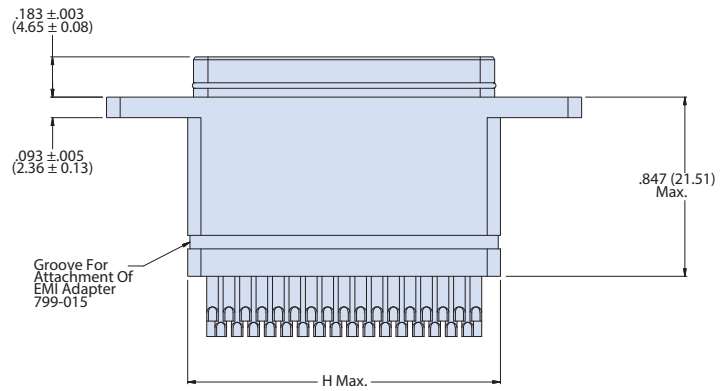
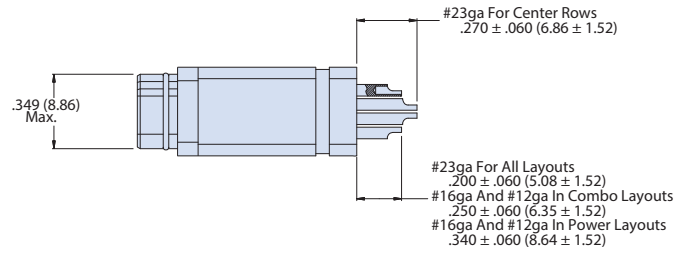
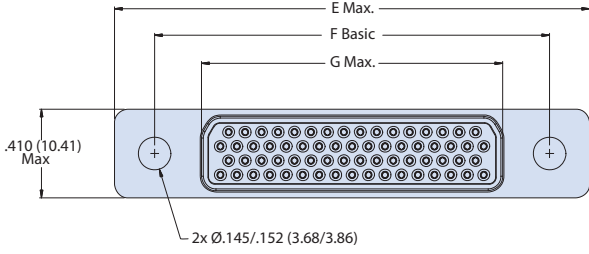

Shell Size H & L

790-070S Size H & L Dimensions								
Shell Size	E Max		F Basic		G Max		H Max	
	In.	mm.	In.	mm.	In.	mm.	In.	mm.
H	2.175	55.25	1.800	45.72	1.385	35.18	1.440	36.58
L	2.420	61.47	2.036	51.71	1.623	41.22	1.675	42.55

Dimensions in inches (millimeters) and are subject to change without notice.

240-790-070
 Series 79 Filtered Cable Plug
 with Solder Cup Termination



240-790-070S SHELL SIZE M DIMENSIONS

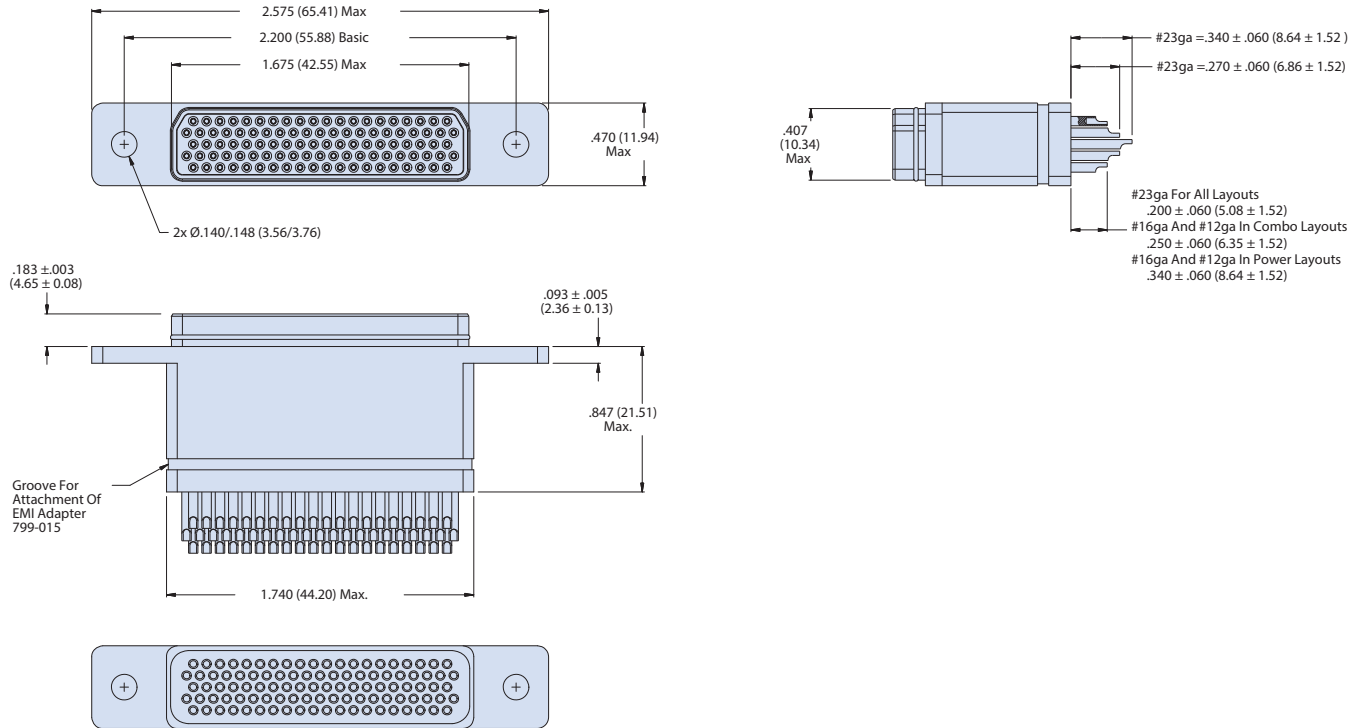

Shell Size M



Dimensions in inches (millimeters) and are subject to change without notice.