

GOT5152T-832

15" XGA TFT Fanless Touch Panel Computer with Intel® Atom™ Processor D2550

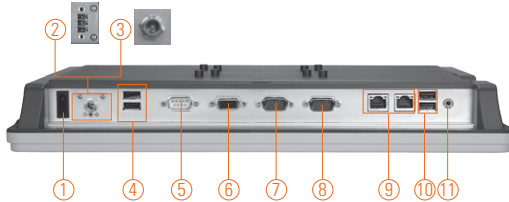

- | | |
|--|---------------------------|
| 1. Power switch (ATX) | 6. VGA |
| 2. Terminal block for DC power input or 3. Screw conn. w/ AC power adapter | 7. COM 1 (RS-232/422/485) |
| 4. USB 2.0 x 2 | 8. COM 2 (RS-232) |
| 5. COM 3 (RS-232) | 9. Ethernet x 2 |
| | 10. USB 2.0 x 2 |
| | 11. Audio (Line-out) |



Introduction

Axiomtek's GOT5152-832 offers the latest fanless technology with Intel® dual core D2550 1.86 GHz CPU. Running Windows or Linux, this system provides great performance for many commercial and industrial applications. This slim design incorporates a 15" 420 nits LCD display providing a bright XGA (1024 x 768) touch screen. Wireless communications is supported with a built-in antenna within the bezel, ready for your choice of optional PCI Express Mini Card and Wi-Fi cards. There are two choices for powering the unit, Class B that includes an external AC to DC power brick with screw-on power connector, or Class A with no power brick, providing a Phoenix style DC connector (10VDC – 30VDC). Using an all industrial-grade IP65-rated design, weighted 7 to 11 lbs (depending on configuration), this computer provides an attractive cost, low power, high performance, reliable quality, slim size and low weight, all new for more demanding applications.

Super Slim & Ultra Light Weight Design

The GOT5152T-832 is a super slim touch panel computer for space-limited environment with its thickness of 54.6 mm and weight of 3.2 kg only, which make it installed everywhere.

Built-in Internal WLAN Antenna

The GOT5152T-832 provides a PCI Express Mini Card slot and a built-in WLAN antenna for wireless network connections. By simply plugging in the wireless LAN card, customers can use the GOT5152T-832 in a wireless LAN/GPRS/GSM/4G environments.

Aluminum Back Chassis with Excellent Thermal Solution

With Axiomtek's patent for plastic plus aluminum mechanism design, the GOT5152T-832 can dissipate the heat easily and keep the system operation stable.

Features

- 15" XGA TFT LCD display with LED backlight
- Fanless cooling system with Intel® Atom™ processor D2550 2 cores @1.86 GHz
- Ultra slim thickness of 54.6 mm
- Super light weight of 3.2 Kg
- PCI Express Mini Card for easy expansion
- Supports optional panel mount/wall mount/VESA arm/desktop stand
- Supports RFID (optional)
- Over-current protection fuse
- Plastic and IP65-rated front bezel



▲ Side view



▲ CompactFlash™ slot with protective cover

Specifications

Front Bezel	IP65, NEMA 4 rugged protection, plastic front bezel	
LCD Panel	Display Type	15" XGA TFT LCD with LED backlight
	Brightness (cd/m ²)	420 nits
	Resolution	1024 x 768
	Viewing Angel (H/V)	160°/140°
Main System	CPU	Intel® Atom™ processor D2550 2 cores @1.86 GHz
	Chipset	Intel® NM10
	System Memory	1 x 204-pin DDR3 800/1066 MHz SO-DIMM max. up to 4GB
	BIOS	AMI UEFI BIOS
	Storage	1 x 2.5" SATA HDD 1 x CompactFlash™
	Watchdog Timer	255 levels, 0-255 sec.
	Onboard Graphics	Integrated in Intel® GFX



Specifications

I/O Connector	2 x RS-232 (COM 2/3) 1 x RS-232/422/485 (default RS-232, COM 1) 1 x VGA 1 x Audio (Line-out) 4 x USB 2.0 2 x 10/100/1000Mbps Ethernet
Expansion Interface	1 x PCI Express Mini Card slot
Touchscreen	Resistive type
Power Input	1. DC version: 10-30VDC with over-current protection fuse 2. AC version: 100-240V AC-DC 60W power adapter
Power Consumption	30W
Dimensions	387.9 mm (15.27") (W) x 54.6 mm (2.14") (D) x 307.7 mm (12.11") (H)
Packing Dimensions	510 mm (20.08") (W) x 105 mm (4.13") (D) x 385 mm (15.16") (H)
Weight (net/gross)	3.2 kg (7.05 lb)/5.1 kg (11.24 lb)
Environment	Operating temperature: 0°C ~ +50°C (+32°F ~ +122°F) (with W.T. DRAM/HDD in airflow condition) 0°C ~ +45°C (+32°F ~ +113°F) (with W.T. DRAM/HDD) Relative humidity: 20% ~ 90% @ 40°C; non-condensing Operation vibration: 2G, 5 ~ 500Hz, random for CompactFlash™
Certificate	UL 60950-1, CE

* Specification and certifications are based on options and may vary.

** W.T.: Wide Temperature. All W.T. supported products have to be sorted by Axiomtek.

Ordering Information

GOT5152T-832-J	15" XGA fanless touch panel computer with Intel® Atom™ processor D2550, 5-wire resistive touch screen, AC-DC 60W power adapter (screw type connector) and EMI class B
GOT5152T-832-DC	15" XGA fanless touch panel computer with Intel® Atom™ processor D2550, 5-wire resistive touch screen and 10-30VDC power input (terminal block connector)

* Specification and certifications are based on options and may vary.

Optional EOS Installation

WES
WES 7

Optional OS Installation

Windows® XP
Windows® 7



▲ Desktop stand



▲ AC power adapter (GOT5152T-832-J)

Dimensions

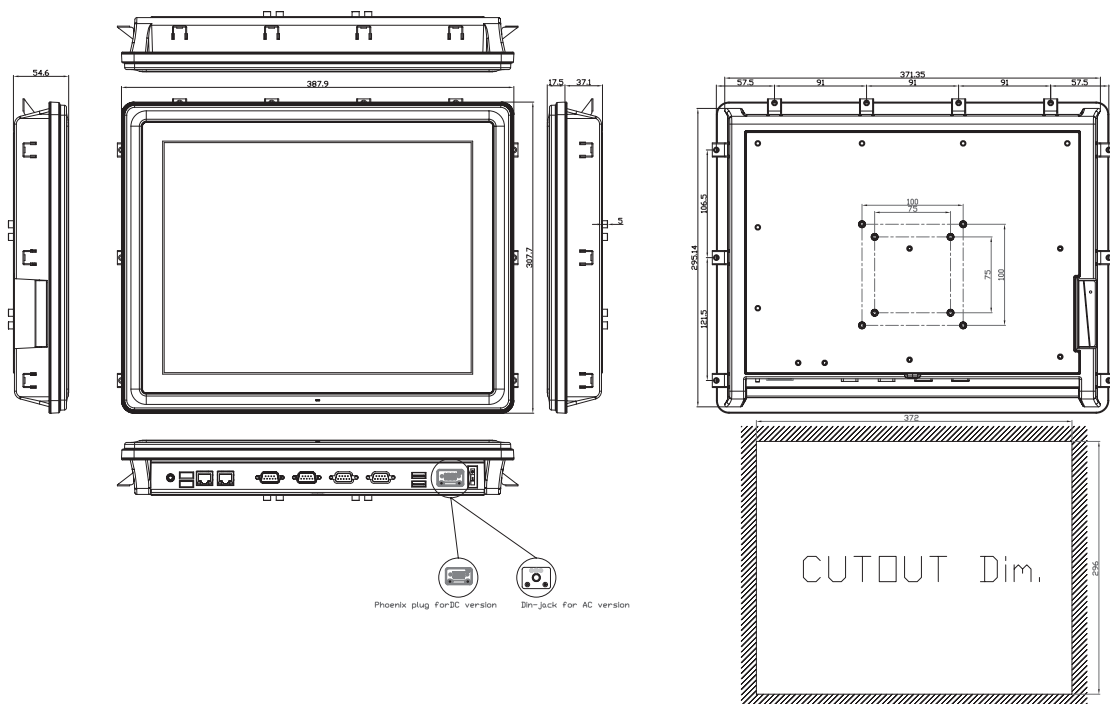

Overview

1

Fanless Touch Panel Computers

Heavy-duty Fanless Touch Panel Computers

Industrial Touch Panel Computers

Industrial Touch panel Monitors

Infotainment Touch Panel Computers

Healthcare & Medical Solutions

Open Frame Panel Computers

Accessories

