

FEATURES

- Flat VSWR characteristic to the temperature change.
- Linear attenuation characteristic to temperature fluctuation.
- RoHS compliant.

APPLICATIONS

- Temperature compensation of microwave high power amplifier.

SPECIFICATIONS

Electrical characteristics

	E-TA3216	E-TA2012
Attenuation	1, 2, 3, 4, 5 dB at 25 °C	1, 2, 3, 4, 5, 6, 7, 8, 9, 10 dB at 25 °C
Tolerance	DC ~ 3 GHz : +0.5 dB, DC ~ 1 GHz : -0.5 dB 1 ~ 3 GHz : -1.0dB (at 25 °C, 50 Ω load)	± 0.5 dB (at 25 °C, 50 Ω load)
Impedance	50 Ω	
VSWR	DC ~ 2 GHz : Less than 1.3 2 ~ 3 GHz : Less than 1.7 (at 25 °C)	Less than 1.3 (at 25 °C)
Temperature Coefficient	N5 ~ N8 at 1 GHz : Please refer to the chart of "Example of Attenuation vs. Temperature"	N1 ~ N8 at 1 GHz : Please refer to the chart of "Example of Attenuation vs. Temperature"
Frequency Range	DC ~ 3 GHz	
Power Rating	100 mW	63 mW
Operating Temperature Range	- 40 °C ~ +100 °C	

Temperature Characteristics

TCA : Temperature Coefficient of Attenuation N1 ~ N8 (dB/dB/°C)		
N1 ; - 0.0119	N4 ; - 0.0047	N7 ; - 0.0026
N2 ; - 0.0088	N5 ; - 0.0041	N8 ; - 0.0019
N3 ; - 0.0062	N6 ; - 0.0035	

Note. Temperature coefficient of E-TA3216 is N5 ~ N8 and E-TA2012 is N1 ~ N8.

PART NUMBER DESIGNATION

E-TA2012 T 1 dB N8

Series name and size

E-TA3216, E-TA2012

Form of packaging

T : Taping (1000 pcs/reel)

Blank : Bulk (100 pcs/in plastic bags)

Temperature Coefficient of Attenuation

(N1, N2, N3, N4, N5, N6, N7, N8)

Attenuation [dB]

(1, 2, 3, 4, 5, 6, 7, 8, 9, 10)

E-TA

THERMAL VARIABLE ATTENUATORS

OUTLINE DIMENSIONS

● **E-TA3216** Unless otherwise specified, tolerance : ± 0.2 (Unit : mm)

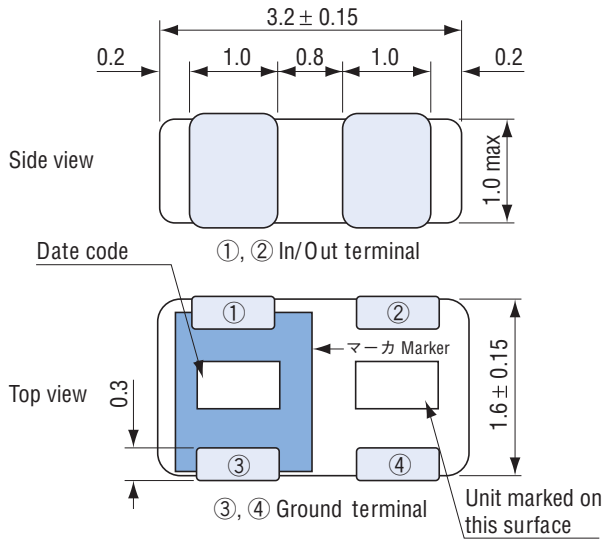

● **E-TA2012** Unless otherwise specified, tolerance : ± 0.2 (Unit : mm)

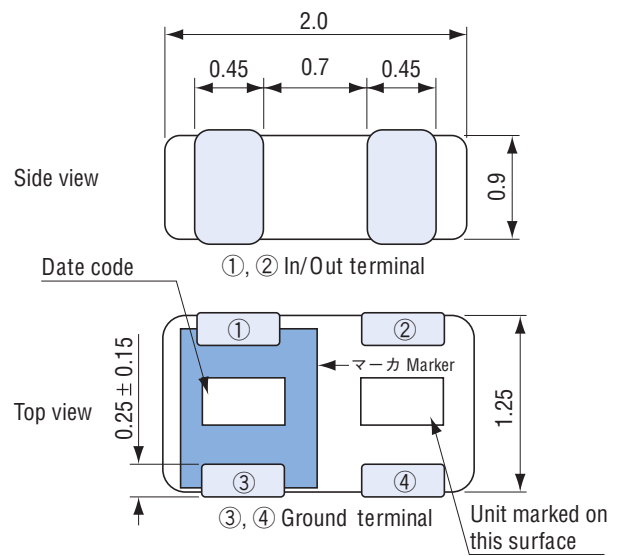

< Marking >

● Date code (2 digits)



● Model code (3 digits)



E-TA

THERMAL VARIABLE ATTENUATORS

RECOMMENDED PAD OUTLINE DIMENSIONS

Unless otherwise specified, tolerance : ± 0.3 (Unit : mm)

E-TA3216

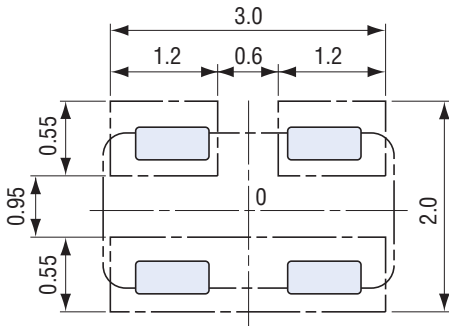

E-TA2012

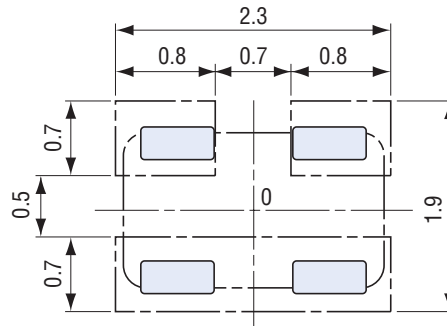

Note) The zero point is center of mounting

EXAMPLE OF ATTENUATION VS. TEMPERATURE : 3 dB

E-TA2012 3dB N*

3 dB Attenuation vs. Temperature

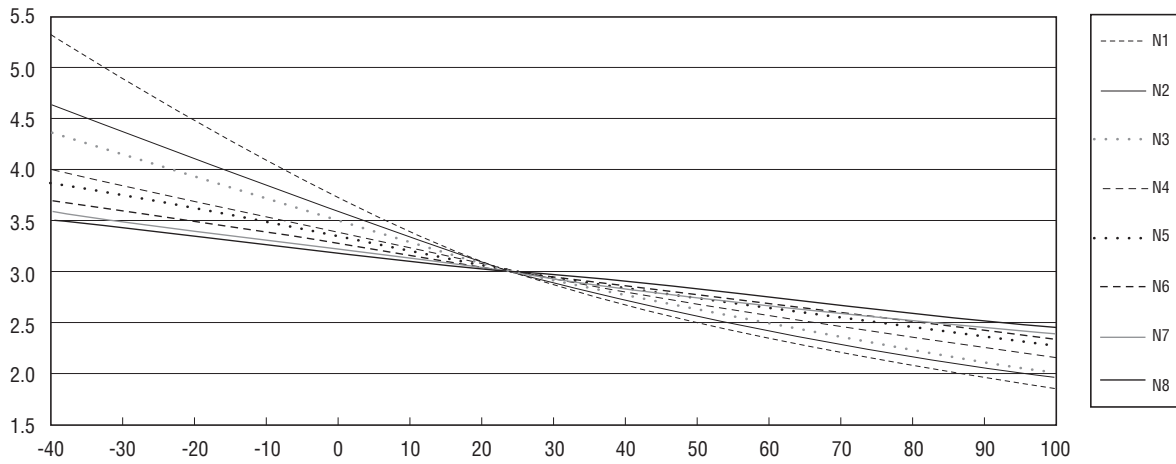

E-TA

THERMAL VARIABLE ATTENUATORS

ENVIRONMENTAL CHARACTERISTICS

Test item	Test conditions	Specifications
A short time overload voltage	Apply the rated voltage of 2.5 times for 5 sec.	Attenuation ± 0.1 dB
Load life	70 \pm 3 °C, Apply rated voltage for 90 minutes followed by 30 minutes Intermission. This cycle is repeated for 1000 hours.	Attenuation ± 0.2 dB
	60 \pm 2 °C, 90 ~ 95 %RH, Apply rated voltage for 90 minutes followed by 30 minutes Intermission. This cycle is repeated for 1000 hours.	Attenuation ± 0.2 dB
Thermal shock	- 40 °C ~ 100 °C (0.5 h), 5 cycles	Attenuation ± 0.1 dB
Vibration	(Vibration) 10 ~ 55 Hz、(Amplitude) 1.5 mm、 10-55-10 Hz/minutes、xyz 2h each	Attenuation ± 0.1 dB
Soldering heat	Peak temperature 255 °C, two times maximum	Attenuation ± 0.1 dB
Solderability	245 \pm 5 °C (lead free), 3 \pm 0.5 s	95 % or more of the immersed area should be adequately wetted.

REFLOW PROFILE FOR SOLDERING HEAT EVALUATION

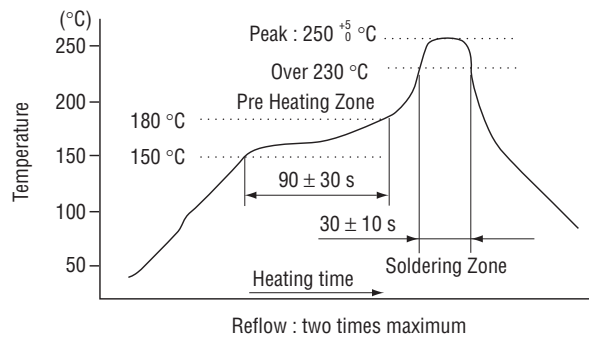

PACKAGING SPECIFICATIONS

- Taping packaging specifications
 - Taping will be accepted for units of 1000 pcs. per reel. Orders will be accepted for units of 1000 pcs. i.e., 1000, 2000, pcs., etc.
 - Taping version is boxed with one reel (1000 pcs.). Maximum number of consecutive missing pieces = 2

- Bulk pack specifications
 - Unit of bulk in a plastic bag package is 100 pcs. per pack.
 - Boxing of bulk in a plastic bag is performed with 200 pcs. per box.

■ CAUTION

(1) Construction

The structure of E-TA3216 and E-TA2012 are designed to withstand flux and cleaning solvents used in the soldering and cleaning process. This sealed structure is also effective for dust and moisture as well, but its capability is not limitless due to inside moving parts.

For the both products, the following conditions are not recommended.

- ① Environmental air with sulphide gas, corrosive gas or reducing gas
- ② Rapid cooling of solvents
- ③ Long time damping into solvents (especially at high temperature)
- ④ Environmental air with high humidity

(2) Notes for storage

Careful attention must be paid when the components are stored.

Environmental temperature, humidity, etc. might affect the solder ability of the terminals and the function of the package. Listed below are notes to be observed.

- ① Under extremely high temperature and humid conditions, the quality decay of the package materials will be accelerated.
- ② It is recommended to store the components in the room at the temperature below 25 °C and the relative humidity below 75 %.
- ③ The environmental air must be free from corrosive gas such as sulphide gas.
- ④ Exposure to the direct sunlight and dust must be avoided.
- ⑤ Handle carefully to avoid deformation of terminals.
- ⑥ Please use the products within one year from the delivery.
- ⑦ Please do not open the smallest unit of package before use.

**Note1. Specifications are subject to change without notice.
Specifications in this catalog are reference.**