

Pb Free Plating Product

HER3001PT thru HER3008PT



30 Ampere Heat Sink Dual Common Cathode High Efficiency Rectifier Diodes

Features

- * Fast switching for high efficiency
- * Low forward voltage drop
- * High current capability
- * Low reverse leakage current
- * High surge current capability

Application

- * Automotive Inverters and Solar Inverters
- * Plating Power Supply, Motor Control, SMPS and UPS
- * Car Audio Amplifiers and Sound Device Systems

Mechanical Data

- * Case: Heatsink TO-3PN open metal package
- * Epoxy: UL 94V-0 rate flame retardant
- * Terminals: Solderable per MIL-STD-202 method 208
- * Polarity: As marked on diode body
- * Mounting position: Any
- * Weight: 0.65 gram approximately

TO-3PN

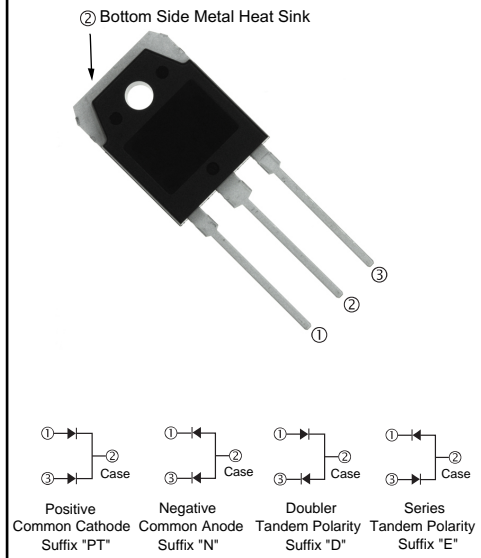

Maximum Ratings and Electrical Characteristics @ $T_A=25^\circ\text{C}$ unless otherwise specified

Single Phase, half wave, 60Hz, resistive or inductive load.
For capacitive load, derate current by 20%.

Characteristic	Symbol	HER 3001PT	HER 3002PT	HER 3003PT	HER 3004PT	HER 3005PT	HER 3006PT	HER 3007PT	HER 3008PT	Unit	
Peak Repetitive Reverse Voltage Working Peak Reverse Voltage DC Blocking Voltage	V_{RRM} V_{RWM} V_R	50	100	200	300	400	600	800	1000	V	
RMS Reverse Voltage	$V_{R(RMS)}$	35	70	140	210	280	420	560	700	V	
Average Rectified Output Current @ $T_C = 100^\circ\text{C}$	I_o	30								A	
Non-Repetitive Peak Forward Surge Current 8.3ms Single half sine-wave superimposed on rated load (JEDEC Method)	I_{FSM}	300								A	
Forward Voltage @ $I_F = 15\text{A}$	V_{FM}	1.0			1.3		1.7			V	
Peak Reverse Current @ $T_A = 25^\circ\text{C}$ At Rated DC Blocking Voltage @ $T_A = 125^\circ\text{C}$	I_{RM}					10			500		μA
Reverse Recovery Time (Note 1)	t_{rr}	50					80				nS
Typical Junction Capacitance (Note 2)	C_j	175					145				pF
Operating and Storage Temperature Range	T_j, T_{STG}	-55 to +150								$^\circ\text{C}$	

Note: 1. Measured with $I_F = 0.5\text{A}$, $I_R = 1.0\text{A}$, $IRR = 0.25\text{A}$. See figure 5.
2. Measured at 1.0 MHz and applied reverse voltage of 4.0V D.C.

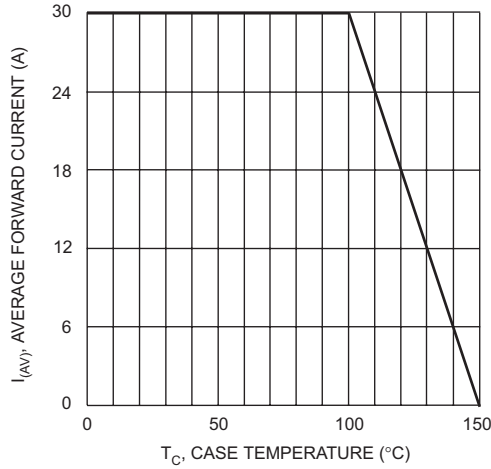

Fig. 1 Forward Current Derating Curve

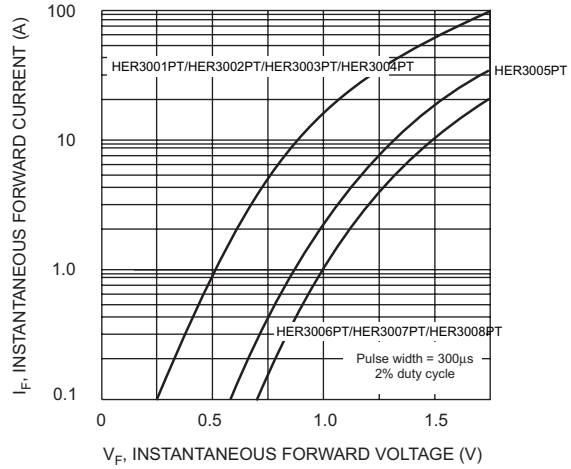

Fig. 2 Typical Forward Characteristics

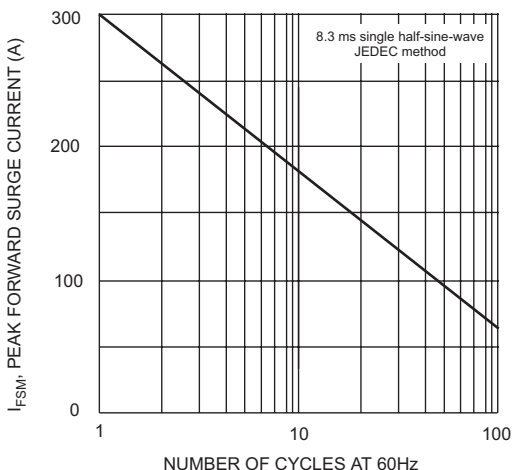

Fig. 3 Maximum Non-Repetitive Surge Current

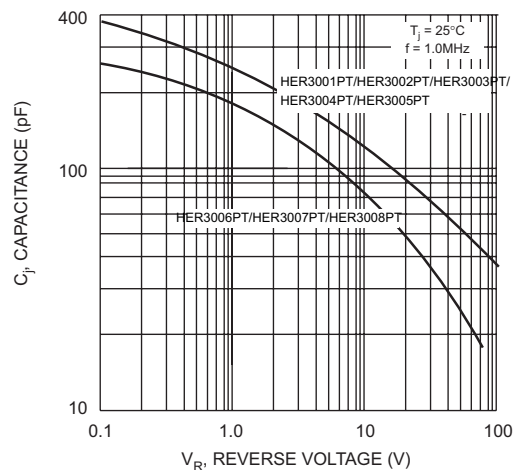
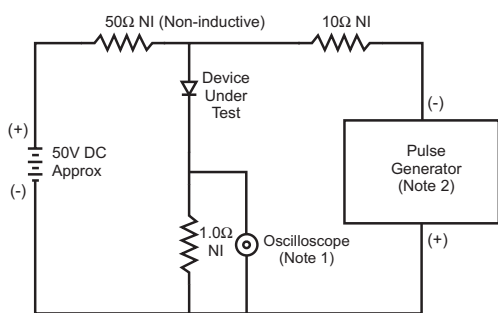
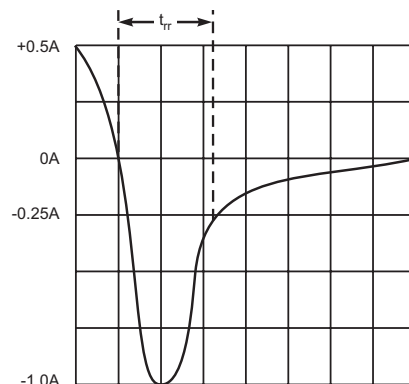

Fig. 4 Typical Junction Capacitance



- Notes:
1. Rise Time = 7.0ns max. Input Impedance = 1.0MΩ, 22pF.
 2. Rise Time = 10ns max. Input Impedance = 50Ω.



Set time base for 5/10ns/cm

Fig. 5 Reverse Recovery Time Characteristic and Test Circuit

Package Information

TO-3PN Package Outline

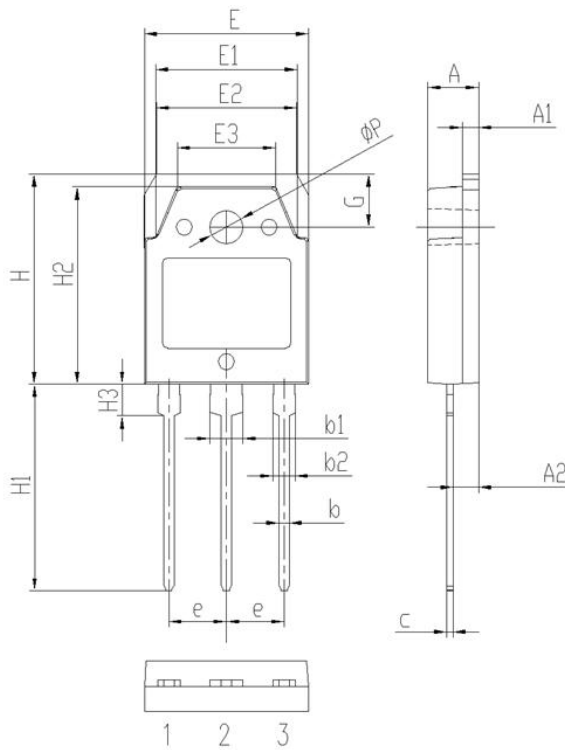

Symbol	Dimensions(millimeters)	
	Min.	Max.
A	4.60	5.00
A1	1.50	2.00
A2	2.20	2.60
b	0.80	1.20
b1	2.90	3.30
b2	1.90	2.30
c	0.40	0.80
e	5.25	5.65
E	15.3	15.7
E1	13.2	13.6
E2	13.1	13.5
E3	9.10	9.50
H	19.7	20.1
H1	19.1	20.1
H2	18.3	18.7
H3	2.80	3.20
G	4.80	5.20
ΦP	3.00	3.40