

DASH NO.	DESCRIPTION	MADE FROM
----------	-------------	-----------

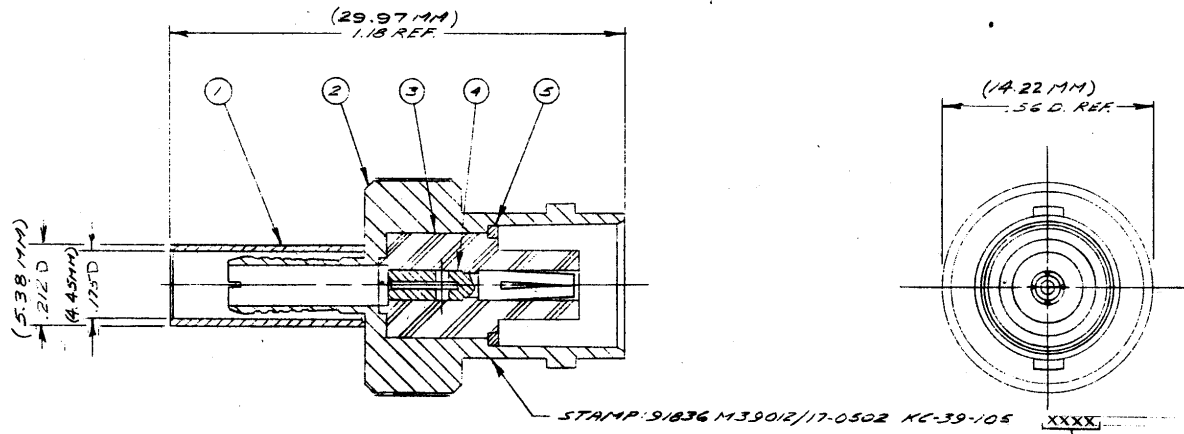

- NOTES:
1. FOR USE WITH RG-180, 180A, 180B, 195 & 195 A/U CABLE.
  2. FOR CABLE TRIMMING USE RTU-116 & RTD-161.
  3. FOR FORMING USE CRIMP DIE 07.
  4. FOR CABLING INSTRUCTIONS SEE CP-485.
  6. ITEM ⑥ TO BE SUPPLIED UNASSEMBLED.

UNLESS OTHERWISE SPECIFIED:

1. TOLERANCES: FRACTIONS & 2 PLACE DECIMALS ± .010	2. REMOVE ALL BURRS. BREAK SHARP EDGES .005 MAX.
3 PLACE DECIMALS ± .004	ANGLES ± 0° 30'
T. I. R. CONCENTRICITY OF ANY 2 DIAMETERS MAY NOT EXCEED HALF THE SUM OF THEIR TOLERANCES.	4. SURFACE ROUGHNESS 83 MICROINCHES RMS MAX.
	5. ALL DIMENSIONS PRIOR TO PLATING.

6	1	CABLING INSTRUCTIONS	
5	1	RETAINER RING	
4	1	BNC CRIMP CAPTIVE CONTACT	1-570-22M30
3	1	INSULATOR	
2	1	K-GRIP BODY	
1	1	K-GRIP SLEEVE	1-4690-2MCT
ITEM	REQ'D	DESCRIPTION	PART NO.

S-D

M39012/17-0502

REVISIONS	
ISSUE	CHANGES
0	ER 14085 MLB 22 JAN 75
1	CN 15973 A GA 15 JUL 76
2	CN 23103 E MD 22 APR 82
3	CN 25533 D CT 13 DEC 83
4	CN 28200 A CAC 5 AUG 85
5	CN 28237 E CAC 18 AUG 85
6	CN 32273 A LNM 13 JUN 90

S-D

KC-39-105

UPRS OR:
REP:
FINISH:
SPEC:
MATL:
SPEC:
<b>BNC JACK</b>

DRAWN MJS	DATE 3 JAN 75
APPR. LI	DATE 22 JAN 75
KINGS ELECTRONICS 40 MARBLEDALE ROAD TUCKAHOE, N. Y. 10707	
M39012/17-0502	