



UR5516A

LINEAR INTEGRATED CIRCUIT

3A BUS TERMINATION REGULATOR

DESCRIPTION

The UTC **UR5516A** is designed to provide a regulated voltage with bi-directional output current for DDR-SDRAM termination.

Current-limit work to limit the short-circuit current, on-chip thermal shutdown provides protection against any combination of overload that would create excessive junction temperature. The output voltage tracks the voltage at V_{REF} pin. A resistor divider connected to V_{IN} , GND and V_{REF} pins is used to provide a half voltage of V_{IN} to V_{REF} pin. In addition, an external ceramic capacitor and an open-drain transistor connected to V_{REF} pin provides soft-start and shutdown control respectively. Pulling and holding the V_{REF} to GND shuts off the output. The output of UTC **UR5516A** will be high impedance after being shut down by V_{REF} or thermal shutdown function.

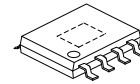

HSOP-8

FEATURES

- * Provide bi-direction current
 - Sourcing or sinking current up to 3A
- * 1.25V/0.9V output for DDR I/O applications
- * Fast transient response
- * High output accuracy
 - $\pm 20\text{mv}$ over load, V_{OUT} offset and temperature
- * Adjustable output voltage by external resistors
- * Current-limit protection
- * On-chip thermal shutdown
- * Shutdown for standby or suspend mode

ORDERING INFORMATION

Ordering Number	Package	Packing
UR5516AG-SH2-R	HSOP-8	Tape Reel

<p>UR5516AG-SH2-R</p> <ul style="list-style-type: none"> (1) Packing Type (2) Package Type (3) Green Package 	<ul style="list-style-type: none"> (1) R: Tape Reel (2) SH2: HSOP-8 (3) G: Halogen Free and Lead Free
---	--

MARKING

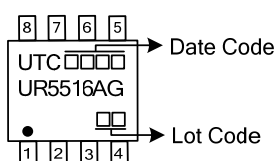

■ PIN CONFIGURATION

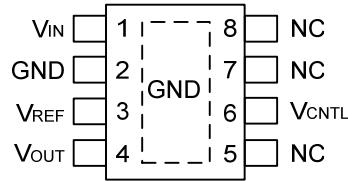

NC: No Connection

■ PIN DESCRIPTION

PIN NAME	I/O	DESCRIPTION
V_{IN}	I	Main power input pin. Connect this pin to a voltage source and an input capacitor. The UTC UR5516A sources current to V_{OUT} pin by controlling the upper NPN pass transistor, providing a current path from V_{IN} pin.
GND	O	Power and signal ground. Connect this pin to system ground plane with shortest traces. The UTC UR5516A sinks current from V_{OUT} pin by controlling the lower NPN pass transistor, providing a current path to GND pin. This pin is also the ground path for internal control circuitry.
V_{CNTRL}	I	Power input pin for internal control circuitry. Connect this pin to a voltage source, providing a bias for the internal control circuitry. A bypass capacitor is usually connected near this pin.
V_{REF}	I	Reference voltage input and active-low shutdown control pin. Apply a voltage to this pin as a reference voltage for the UTC UR5516A . Connect this pin to a resistor divider, between V_{IN} and GND, and a capacitor for soft-start and filtering noise purposes. Applying and holding this pin low by an open-drain transistor to shut down the output.
V_{OUT}	O	Output pin of the regulator. Connect this pin to load. Output capacitors connected this pin improves stability and transient response. The output voltage tracks the reference voltage and is capable of sourcing or sinking current up to 3A.

■ BLOCK DIAGRAM

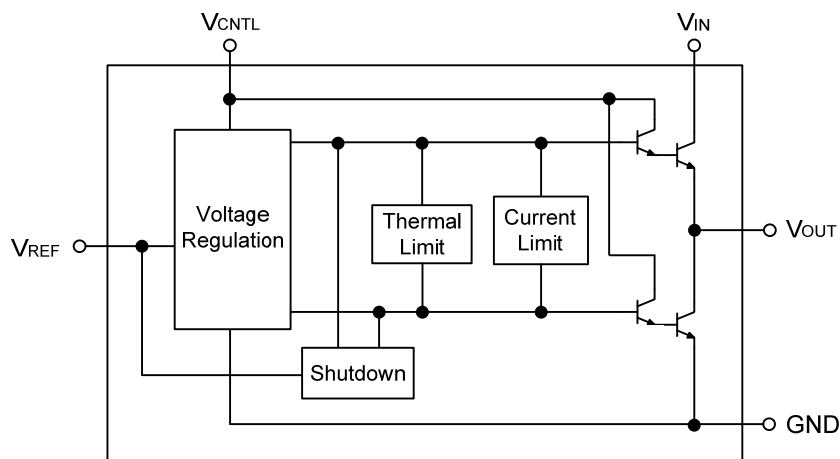

■ ABSOLUTE MAXIMUM RATINGS

PARAMETER	SYMBOL	RATINGS	UNIT
V _{CNTL} Supply Voltage, V _{CNTL} to GND	V _{CNTL}	-0.2 ~ 7	V
V _{IN} Supply Voltage, V _{IN} to GND	V _{IN}	-0.2 ~ 3.9	V
Power Dissipation	P _D	Internally Limited	W
Junction Temperature	T _J	+150	°C
Storage Temperature	T _{STG}	-40 ~ +150	°C

Note Absolute maximum ratings are those values beyond which the device could be permanently damaged. Absolute maximum ratings are stress ratings only and functional device operation is not implied.

■ RECOMMENDED OPERATING CONDITIONS

PARAMETER	SYMBOL	RANGES	UNIT
V _{CNTL} Supply Voltage (Note 1)	V _{CNTL}	3.1 ~ 6	V
V _{IN} Supply Voltage (Note 2)	V _{IN}	1.2 ~ 3.5	V
V _{REF} Input Voltage	V _{REF}	0.85 ~ 1.75	V
V _{OUT} Output Voltage (Note 3)	V _{OUT}	V _{REF} ± 0.02	V
V _{OUT} Output Current (Note 4,5)	I _{OUT}	-3 ~ +3	A
Junction Temperature	T _J	0 ~ +125	°C

Notes: 1. Please always keep V_{CNTL}-V_{OUT}>1.9V for good regulation.

2. Please supply enough voltage to V_{IN} for sourcing desired maximum output current. Please refer to the V_{IN} Dropout Voltage vs. Output Current in the Typical Characteristics.
3. The V_{OUT} is regulated to the V_{REF} with additional voltage offset and load regulation except over-load conditions.
4. The symbol "+" means the V_{OUT} sources current to load; the symbol "-" means the V_{OUT} sinks current to GND.
5. The max. I_{OUT} varies with the T_J and the voltages of V_{IN}-V_{OUT} and V_{OUT}. Please refer to the Typical Characteristics.

■ THERMAL DATA

PARAMETER	SYMBOL	RATINGS	UNIT
Thermal Resistance	θ _{JA}	80	°C/W

■ ELECTRICAL CHARACTERISTICS

($T_J=25^{\circ}\text{C}$, $V_{\text{CNTL}}=3.3\text{V}$, $V_{\text{IN}}=2.5\text{V}/1.8\text{V}$, $V_{\text{REF}}=0.5V_{\text{IN}}$, unless otherwise specified)

PARAMETER	SYMBOL	TEST CONDITIONS	MIN	TYP	MAX	UNIT
Output Voltage	V_{OUT}	$I_{\text{OUT}}=0\text{A}$		V_{REF}		V
System Accuracy		Over temperature, V_{OUT} offset, and load regulation	-20		20	mV
Offset Voltage ($V_{\text{OUT}}-V_{\text{REF}}$)	$V_{\text{O(OFF)}}$	$I_{\text{OUT}}=+10\text{mA}$	-20			mV
		$I_{\text{OUT}}=-10\text{mA}$			20	
Load Regulation	ΔV_{OUT}	$I_{\text{OUT}}=+10\text{mA} \sim +3\text{A}$			2	%
		$I_{\text{OUT}}= -10\text{mA} \sim -3\text{A}$			2	
Current Limit	I_{LIMIT}	Sourcing Current ($V_{\text{IN}}=2.5\text{V}$)	$T_J=25^{\circ}\text{C}$	+3	+3.6	A
			$T_J=125^{\circ}\text{C}$		+3.1	
		Sinking Current ($V_{\text{IN}}=2.5\text{V}$)	$T_J=25^{\circ}\text{C}$	-3	-3.6	
			$T_J=125^{\circ}\text{C}$		-3.1	
		Sourcing Current ($V_{\text{IN}}=1.8\text{V}$)	$T_J=25^{\circ}\text{C}$	+2.9	+3.2	
			$T_J=125^{\circ}\text{C}$		+2.6	
		Sinking Current ($V_{\text{IN}}=1.8\text{V}$)	$T_J=25^{\circ}\text{C}$	-2.9	-3.2	
			$T_J=125^{\circ}\text{C}$		-2.6	
Thermal Shutdown Temperature	T_{SHDN}	Rising T_J		183		$^{\circ}\text{C}$
Thermal Shutdown Hysteresis	T_{HYS}			42		$^{\circ}\text{C}$
V_{CNTL} Supply Current	I_{CNTL}	$I_{\text{OUT}}=0\text{A}$	1	2	3	mA
		$I_{\text{OUT}}=\pm 3\text{A}$ (Normal Operation)		50	110	
		$V_{\text{REF}}=\text{GND}$ (Shutdown)		2.0		
V_{REF} Bias Current (The current flows out of V_{REF})	I_{BIAS}	$V_{\text{REF}}=1.25\text{V}/0.9\text{V}$ (Normal Operation)		200	500	nA
		$V_{\text{REF}}=\text{GND}$ (Shutdown)		20	40	μA
Shutdown Threshold Voltage	V_{SHDN}		0.2	0.35	0.65	V

■ APPLICATIONS CIRCUIT

1. General Application

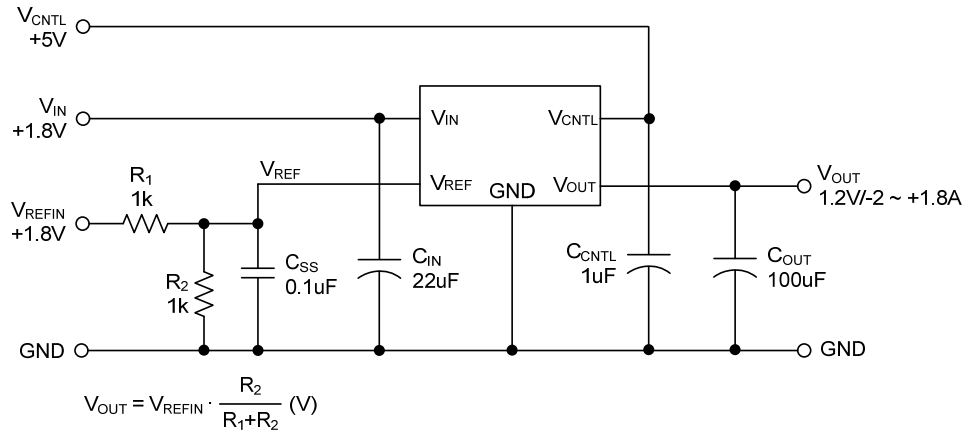

2. For V_{OUT}=1.25V/0.9V

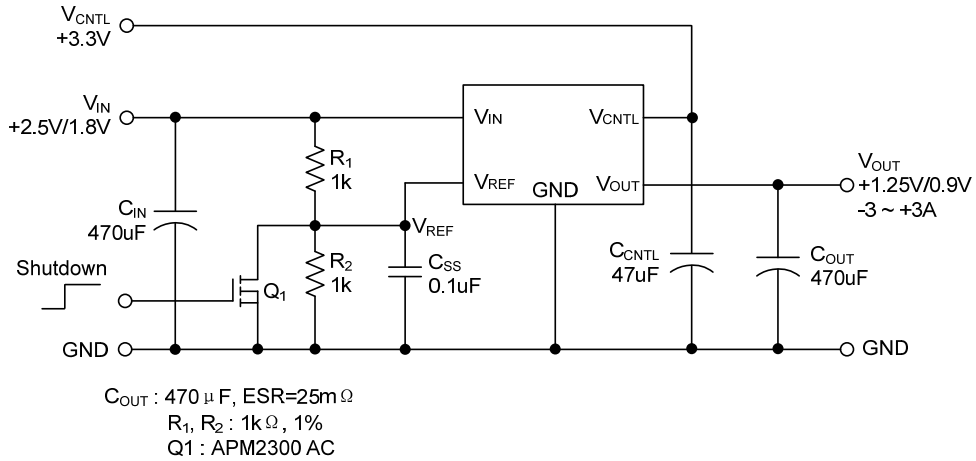

Note : Since R1 and R2 are very small, the voltage offset caused by the bias current of V_{REF} can be ignore.

3. For V_{OUT}=1.4V

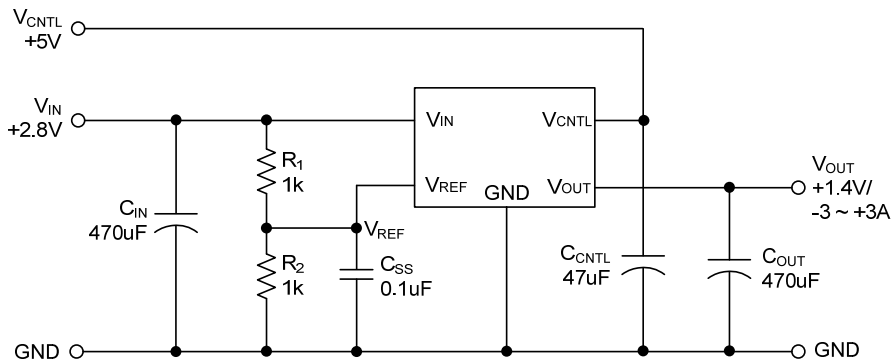

■ OPERATING WAVEFORMS

1. Load Transient Response: $I_{OUT} = +10mA \rightarrow +3A \rightarrow +10mA$

- $V_{IN} = 2.5V$, $V_{CNTL} = 3.3V$
- V_{REF} is 1.250V supplied by a regulator
- $C_{OUT} = 470\mu F/10V$, $ESR = 30m\Omega$
- I_{OUT} slew rate = $\pm 3A/\mu S$

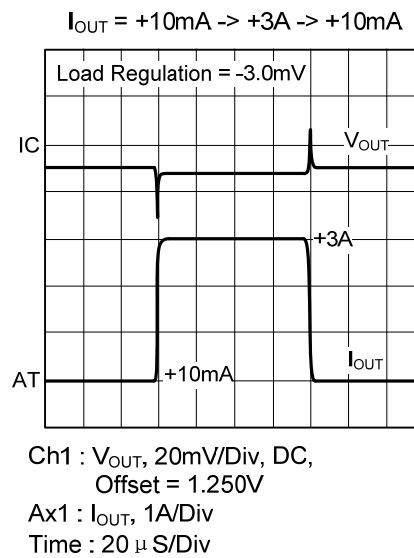

2. Load Transient Response: $I_{OUT} = -10mA \rightarrow -3A \rightarrow -10mA$

- $V_{IN} = 2.5V$, $V_{CNTL} = 3.3V$
- V_{REF} is 1.250V supplied by a regulator
- $C_{OUT} = 470\mu F/10V$, $ESR = 30m\Omega$
- I_{OUT} slew rate = $\pm 3A/\mu S$

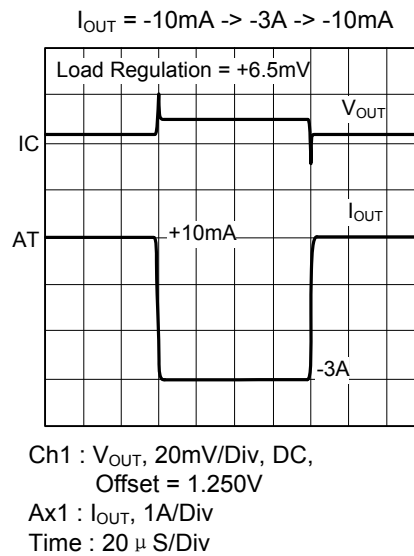

■ OPERATING WAVEFORMS(Cont.)

3. Load Transient Response: $I_{OUT} = +3A \rightarrow -3A \rightarrow +3A$

- $V_{IN} = 2.5V$, $V_{CNTL} = 3.3V$
- V_{REF} is 1.250V supplied by a regulator
- $C_{OUT} = 470\mu F/10V$, $ESR = 30m\Omega$
- I_{OUT} slew rate = $\pm 3A/\mu S$

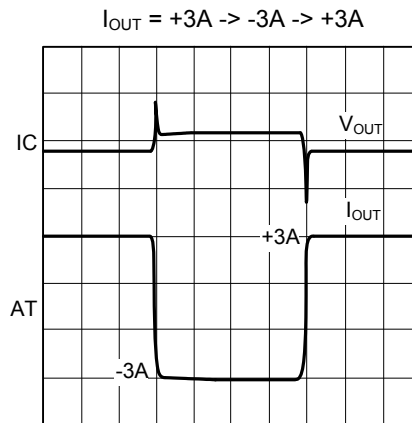

Ch1 : V_{OUT} , 50mV/Div, DC,
Offset = 1.250V
Ax1 : I_{OUT} , 2A/Div
Time : 20 μ S/Div

4. Short-Circuit Test

- $V_{IN} = 2.5V$, $V_{CNTL} = 3.3V$

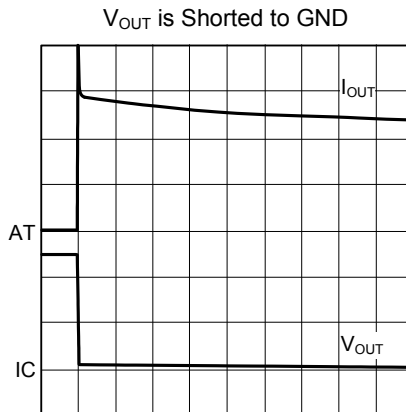

Ch1 : V_{OUT} , 500mV/Div, DC,
Offset = 1.250V
Ax1 : I_{OUT} , 2A/Div
Time : 5mS/Div

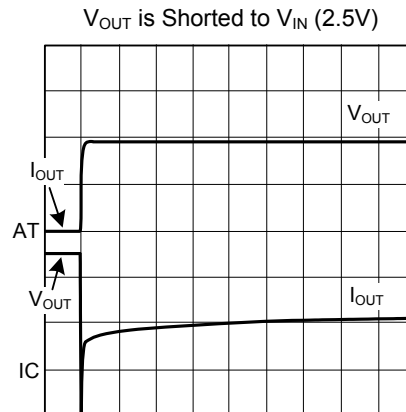

Ch1 : V_{OUT} , 500mV/Div, DC,
Offset = 1.250V
Ax1 : I_{OUT} , 2A/Div
Time : 5mS/Div

■ TYPICAL CHARACTERISTICS

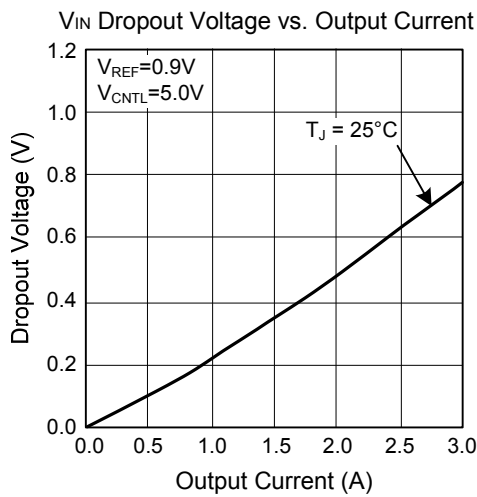
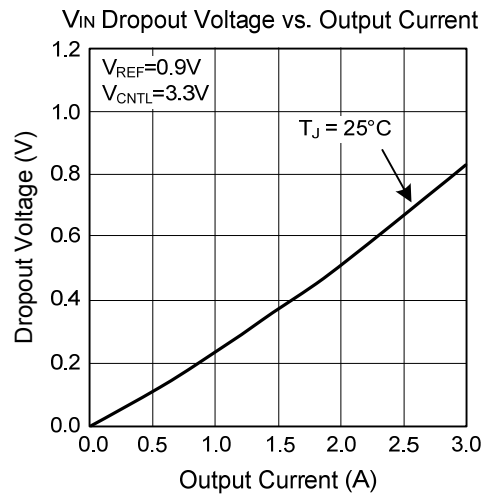
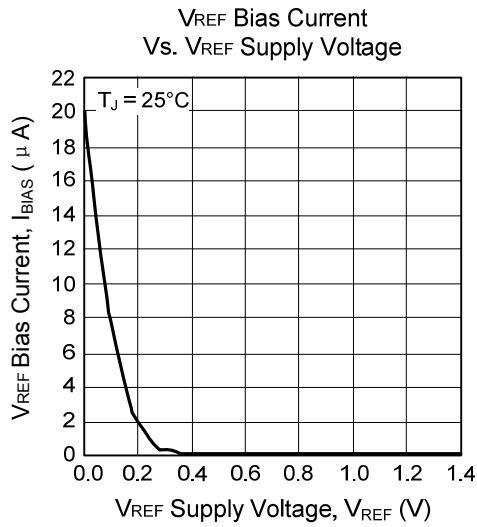

UTC assumes no responsibility for equipment failures that result from using products at values that exceed, even momentarily, rated values (such as maximum ratings, operating condition ranges, or other parameters) listed in products specifications of any and all UTC products described or contained herein. UTC products are not designed for use in life support appliances, devices or systems where malfunction of these products can be reasonably expected to result in personal injury. Reproduction in whole or in part is prohibited without the prior written consent of the copyright owner. The information presented in this document does not form part of any quotation or contract, is believed to be accurate and reliable and may be changed without notice.