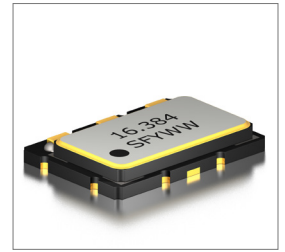
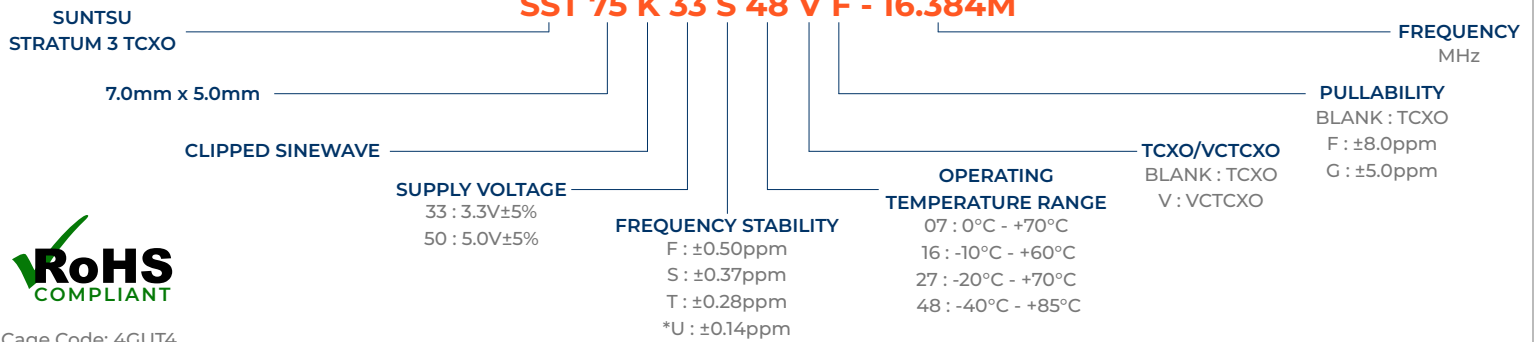

Features
<ul style="list-style-type: none"> Stratum 3 (Overall ± 4.6ppm) Clipped Sinewave (VC)TCXO Tape and Reel

Applications
<ul style="list-style-type: none"> Base Stations Stratum 3 Small Cell

Part Numbering Guide
SST 75 K 33 S 48 V F - 16.384M

Cage Code: 4GUT4

To customize your parameters contact a Suntsu representative.

* Option U is available only for -20°C to +70°C

Electrical Parameters	Units	Minimum	Typical	Maximum	Remarks
Frequency Range	MHz	5		26	
Frequency Tolerance at +25°C	ppm	-4.6		+4.6	
Freq. Stability vs. Op Temp.	ppm	-0.28		+0.28	See part numbering guide for options.
Holdover Stability	ppm	+0.37		+0.37	
Operating Temperature	°C	-40		+85	See part numbering guide for options.
Storage Temperature	°C	-55		+125	
Supply Voltage (V _{DD}) - 3.3V Option	V	3.135	3.3	3.465	
Supply Voltage (V _{DD}) - 5.0V Option	V	4.750	5.0	5.250	
Current (I _{DD})	mA			6	
Voltage (VC, VCTCXO) - 3.3V Option	V	0.5		2.5	
Voltage (VC, VCTCXO) - 5.0V Option	V	0.5		2.5	
Pullability (VCTCXO)	ppm	± 5.0		± 8.0	See part numbering guide for options.
Linearity (VCTCXO)	%			10	
Output Load (Clipped Sinewave)	k Ω //pF			10//10	
Output Logic Levels	V _{P-P}	0.8			
Symmetry (Duty Cycle)	%	40	50	60	
Tri-State Input Voltage (Enabled)	V	0.7*V _{DD}			
Tri-State Input Voltage (Disabled)	V			0.3*V _{DD}	
Start-Up Time	ms			2	
VC Input Impedance (VCTCXO)	k Ω	100			
Phase Noise (Typical) 100Hz Offset	dBc/Hz		-120		
Phase Noise (Typical) 1KHz Offset	dBc/Hz		-140		
Phase Noise (Typical) 10KHz Offset	dBc/Hz		-148		

Outline Drawing & Land Pattern

All dimensions are in millimeters (mm) unless otherwise noted. Drawings are not to scale.

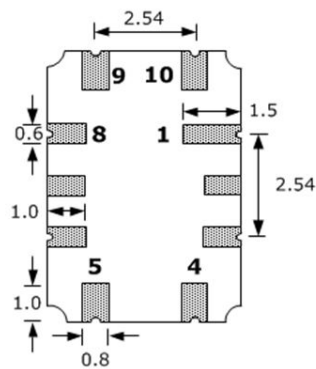
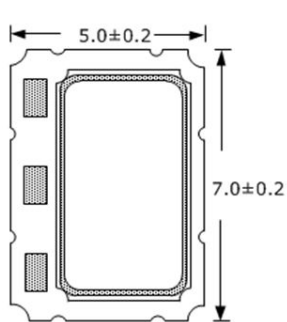

RECOMMENDED LAND PATTERN

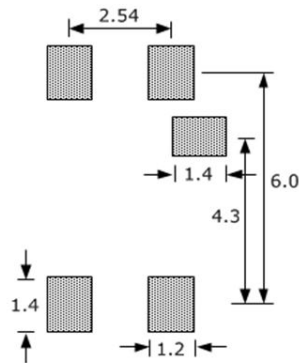

PIN	FUNCTION
1	NC
4	GND
5	OUTPUT
8	TRI-STATE
9	V _{DD}
10	V _c (VCTCXO) or GND (TCXO)

Test Circuit (Clipped Sinewave)

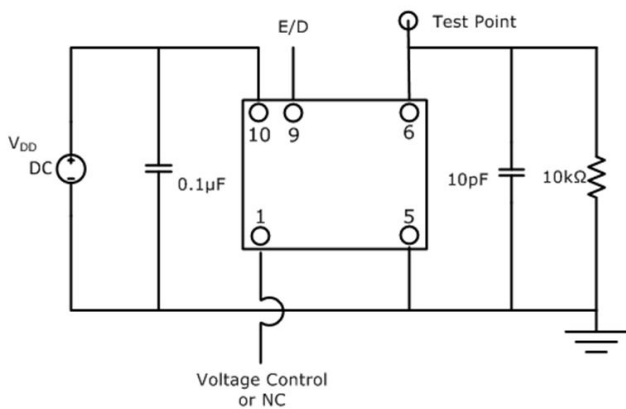

Waveform (Clipped Sinewave)

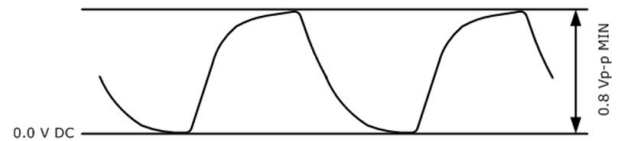

Typical Phase Noise Performance (Measured By Agilent E5052A)

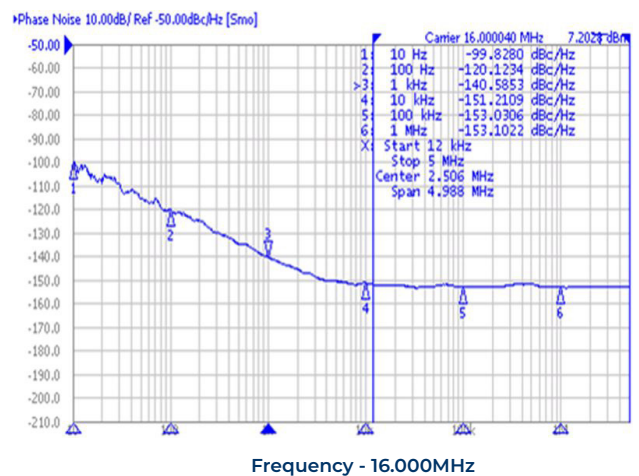
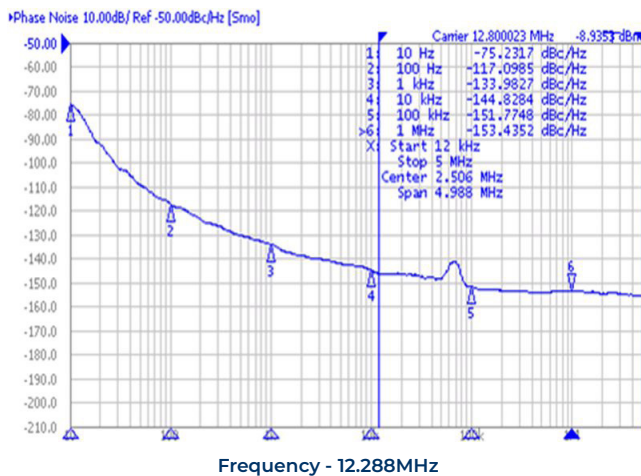

Typical Jitter Performance (Measured By Agilent E5052A)

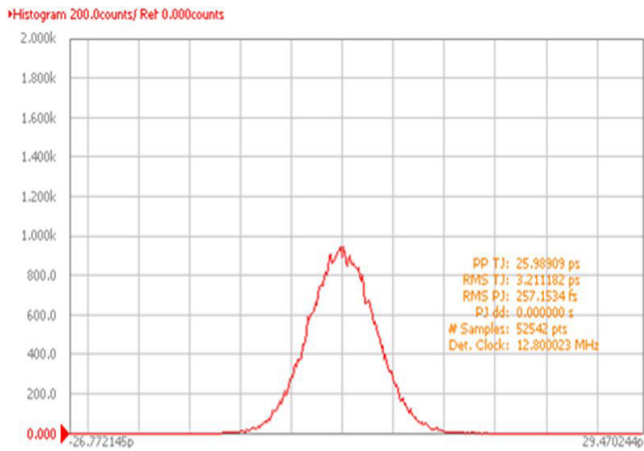

Frequency - 12.288MHz

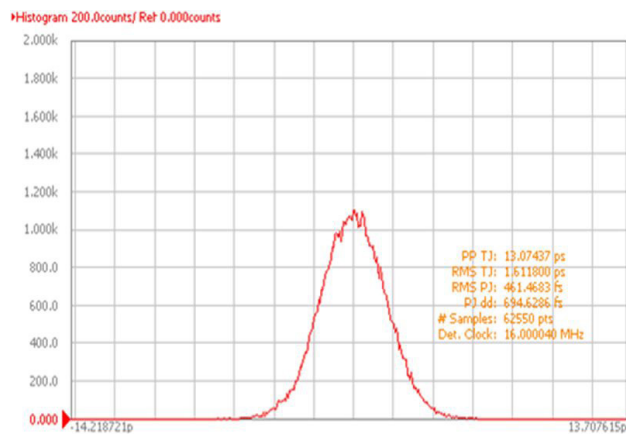

Frequency - 16.000MHz

Reflow Profile

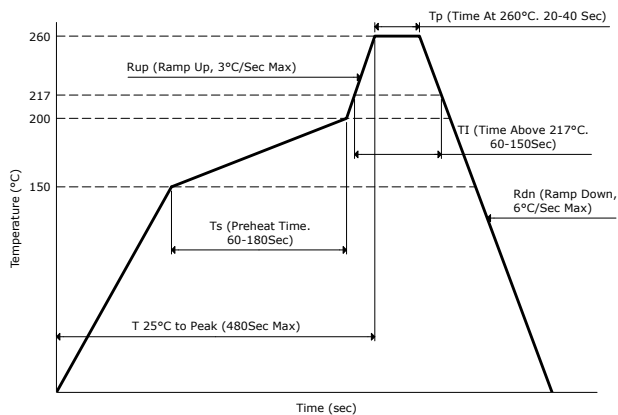

Part Marking

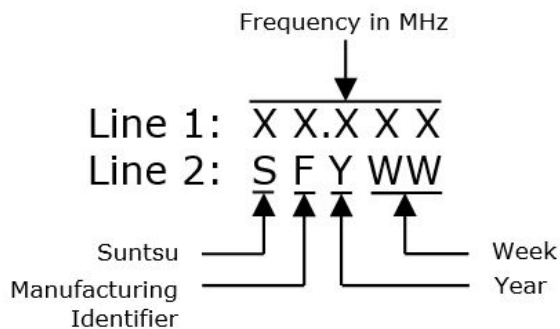

Tape And Reel Dimensions

All dimensions are in millimeters (mm) unless otherwise noted. Drawings are not to scale.

1,000pcs/Reel

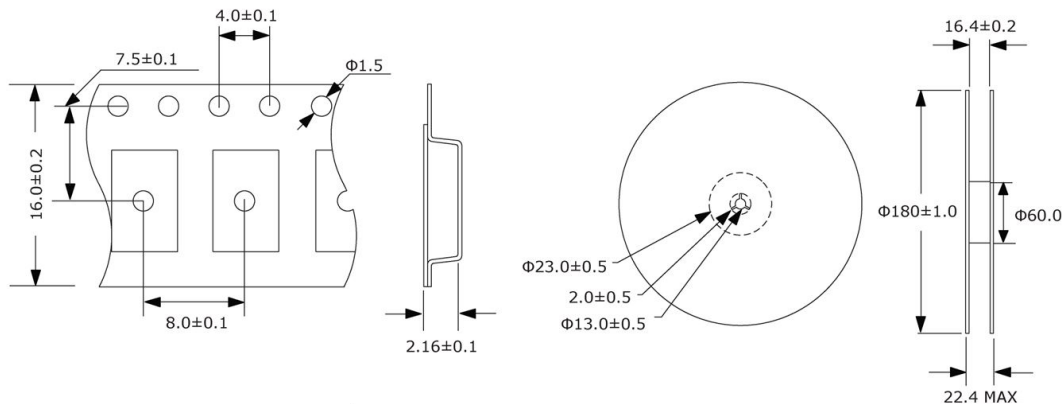

Environmental Specifications		Mechanical Specifications	
Temperature Cycling	MIL-STD-883, Method 1010, Condition B	Mechanical Shock	MIL-STD-202, Method 213, Condition B
Fine Leak Test	MIL-STD-883, Method 1014, Condition A	Vibration	MIL-STD-883, Method 2007, Condition A
Gross Leak Test	MIL-STD-883, Method 1014, Condition C	Moisture Resistance	MIL-STD-883, Method 1004
Solderability	MIL-STD-883, Method 2003	Resistance to Solvents	MIL-STD-202, Method 215
Moisture Sensitivity	J-STD-020, MSL 1	Resistance to Soldering Heat	MIL-STD-202, Method 210, Condition K