

## Programmable 4-PLL VCXO Clock Synthesizer with 1.8V, 2.5V and 3.3V LVCMOS Outputs

### FEATURES

- Member of Programmable Clock Generator Family
  - CDCE949/CDCEL949: 4 PLLs, 9 Outputs
  - CDCE937/CDCEL937: 3 PLLs, 7 Outputs
  - CDCE925/CDCEL925: 2 PLLs, 5 Outputs
  - CDCE913/CDCEL913: 1 PLLs, 3 Outputs
- In-System Programmability and EEPROM
  - Serial Programmable Volatile Register
  - Non-Volatile EEPROM to Store Customer Settings
- Very Flexible Input Clocking Concept
  - External Crystal: 8 to 32 MHz
  - On-Chip VCXO: Pull-Range  $\pm 150$  ppm
  - Single-Ended LVCMOS up to 160 MHz
- Selectable Output Frequency up to 230 MHz
- Very Low-Noise PLL Core
  - Integrated PLL Loop Filter Components
  - Very Low Period Jitter (typ 60 ps)
- Highly Flexible Clock Driver

- Three User-Definable Control Inputs [S0/S1/S2] e.g. SSC-Selection, Frequency Switching, Output Enable or Power Down
- Programmable SSC Modulation
- Enables 0-PPM Clock Generation
- Generates Common Clock Frequencies Used with TI DaVinci™, OMAP™, DSPs
- Generates Highly-Accurate Clocks for Video, Audio, USB, IEEE1394, RFID, Bluetooth™, WLAN, Ethernet and GPS
- 1.8 V Device Power Supply
- Separate Output Supply Pins
  - CDCE949: 3.3 V and 2.5 V
  - CDCEL949: 1.8 V
- Wide Temperature Range  $-40^{\circ}\text{C}$  to  $85^{\circ}\text{C}$
- Packaged in TSSOP
- Development and Programming Kit for Ease PLL Design and Programming (TI-Pro Clock)

### APPLICATIONS

- D-TV, HD-TV, STB, IP-STB, DVD-Player, DVD-Recorder, Printer
- General Purpose Frequency Synthesizing

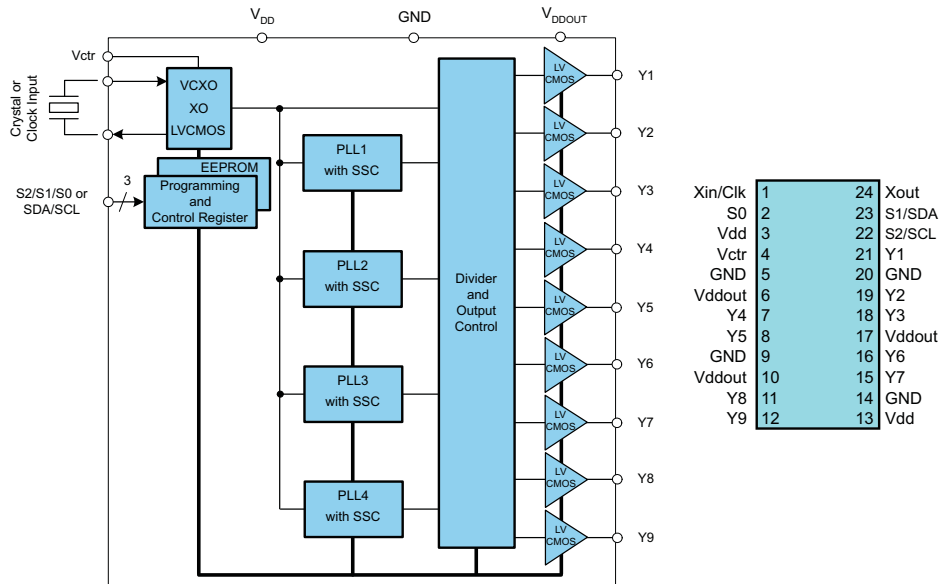

Please be aware that an important notice concerning availability, standard warranty, and use in critical applications of Texas Instruments semiconductor products and disclaimers thereto appears at the end of this data sheet.

DaVinci, OMAP, Pro Clock are trademarks of Texas Instruments.  
BlueTooth is a trademark of Bluetooth SIG, Inc.  
I2C is a trademark of Philips Electronics.



These devices have limited built-in ESD protection. The leads should be shorted together or the device placed in conductive foam during storage or handling to prevent electrostatic damage to the MOS gates.

## DESCRIPTION

The CDCE949 and CDCEL949 are modular PLL-based low cost, high-performance, programmable clock synthesizers, multipliers and dividers. They generate up to 9 output clocks from a single input frequency. Each output can be programmed in-system for any clock frequency up to 230 MHz, using up to four independent configurable PLLs.

The CDCx949 has separate output supply pins,  $V_{DDOUT}$ , 1.8 V for the CDCEL949, and 2.5 V to 3.3 V for CDCE949.

The input accepts an external crystal or LVCMOS clock signal. If an external crystal is used, an on-chip load capacitor is adequate for most applications. The value of the load capacitor is programmable from 0 to 20 pF. Additionally, an on-chip VCXO is selectable, allowing synchronization of the output frequency to an external control signal, i.e. a PWM signal.

The deep M/N divider ratio allows the generation of zero-ppm audio/video, networking (WLAN, BlueTooth™, Ethernet, GPS) or Interface (USB, IEEE1394, Memory Stick) clocks from a reference input frequency such as 27-MHz.

All PLLs support SSC (Spread-Spectrum Clocking). SSC can be Center-Spread or Down-Spread clocking. This is a common technique to reduce electro-magnetic interference (EMI).

Based on the PLL frequency and the divider settings, the internal loop-filter components are automatically adjusted to achieve high stability, and to optimize the jitter-transfer characteristics of each PLL.

The device supports non-volatile EEPROM programming for easy customization of the device to the application. It is preset to a factory-default configuration (see the [Default Device Configuration](#) section). It can be reprogrammed to a different application configuration before PCB assembly, or reprogrammed by in-system programming. All device settings are programmable through the SDA/SCL bus, a 2-wire serial interface.

Three programmable control inputs, S0, S1 and S2, can be used to control various aspects of operation including frequency selection, changing the SSC parameters to lower EMI, PLL bypass, power down, and choosing between low level or 3-state for the output-disable function.

The CDCx949 operates in a 1.8-V environment. It is characterized for operation from –40°C to 85°C.

## DEVICE INFORMATION

### TERMINAL FUNCTIONS

TERMINAL		I/O	
NAME	NO. (TSSOP24)		
Y1, Y2, ...Y9	21, 19, 18, 7, 8, 16, 15, 11, 12	O	LVCMOS outputs
Xin/CLK	1	I	Crystal oscillator input or LVCMOS clock input (selectable via SDA/SCL bus)
Xout	24	O	Crystal oscillator output (leave open or pull up when not used)
V <sub>Ctrl</sub>	4	I	VCXO control voltage (leave open or pull up when not used)
V <sub>DD</sub>	3, 13	Power	1.8V power supply for the device
V <sub>DDOUT</sub>	6, 10, 17	Power	<b>CDCEL949:</b> 1.8 V supply for all outputs <b>CDCE949:</b> 3.3 V or 2.5 V supply for all outputs
GND	5, 9, 14, 20	Ground	Ground
S0	2	I	User-programmable control input S0; LVCMOS inputs; internal pull-up 500 kΩ
SDA / S1	23	I/O / I	<b>SDA:</b> Bi-directional serial data input/output (default configuration), LVCMOS; internal pull-up 500 kΩ; or <b>S1:</b> User-programmable control input; LVCMOS inputs; internal pull-up 500 kΩ
SCL / S2	22	I	<b>SCL:</b> Serial clock input (default configuration), LVCMOS; internal pull-up 500 kΩ; or <b>S2:</b> User-programmable control input; LVCMOS inputs; internal pull-up 500 kΩ

FUNCTIONAL BLOCK DIAGRAM

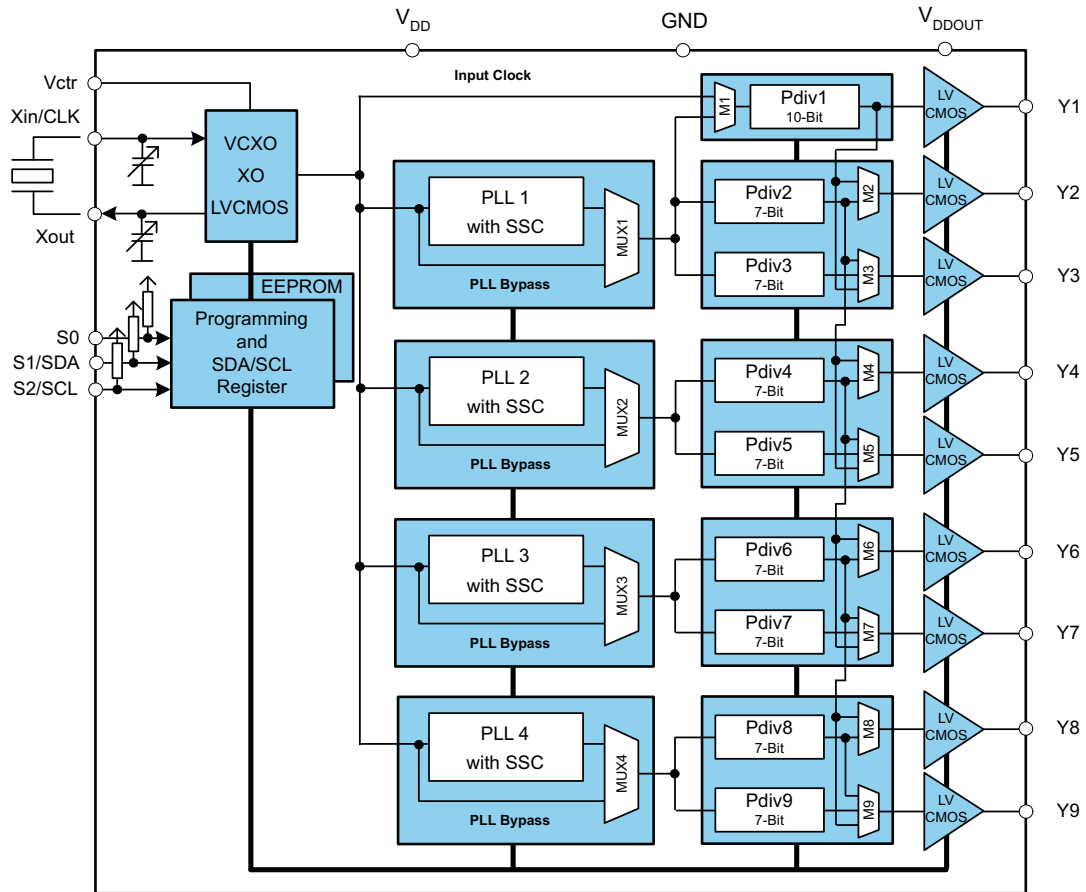

ABSOLUTE MAXIMUM RATINGS

over operating free-air temperature range (unless otherwise noted) <sup>(1)</sup>

		VALUE	UNIT
V <sub>DD</sub>	Supply voltage range	-0.5 to 2.5	V
V <sub>I</sub>	Input voltage range <sup>(2)</sup>	-0.5 to V <sub>DD</sub> + 0.5	V
V <sub>O</sub>	Output voltage range <sup>(2)</sup>	-0.5 to V <sub>DDOUT</sub> + 0.5	V
I <sub>I</sub>	Input current (V <sub>i</sub> < 0, V <sub>i</sub> > V <sub>DD</sub> )	20	mA
I <sub>O</sub>	Continuous output current	50	mA
T <sub>stg</sub>	Storage temperature range	-65 to 150	°C
T <sub>J</sub>	Maximum junction temperature	125	°C

(1) Stresses beyond those listed under *absolute maximum ratings* may cause permanent damage to the device. These are stress ratings only and functional operation of the device at these or any other conditions beyond those indicated under *recommended operating conditions* is not implied. Exposure to absolute-maximum-rated conditions for extended periods may affect device reliability.

(2) The input and output negative voltage ratings may be exceeded if the input and output clamp-current ratings are observed.

## THERMAL RESISTANCE FOR TSSOP (PW) PACKAGE<sup>(1)</sup>

PARAMETER		AIRFLOW (lfm)	TSSOP24 °C/W
T <sub>JA</sub>	Thermal Resistance Junction to Ambient	0	85
		150	80
		250	78
		500	76
T <sub>JC</sub>	Thermal Resistance Junction to Case	—	26

(1) The package thermal impedance is calculated in accordance with JESD 51 and JEDEC2S2P (high-k board).

## RECOMMENDED OPERATING CONDITIONS

			MIN	NOM	MAX	UNIT
V <sub>DD</sub>	Device supply voltage		1.7	1.8	1.9	V
V <sub>DD(OUT)</sub>	Output Yx supply voltage	CDCE949	2.3		3.6	V
		CDCEL949	1.7		1.9	
V <sub>IL</sub>	Low level input voltage LVCMOS				0.3 × V <sub>DD</sub>	V
V <sub>IH</sub>	High level input voltage LVCMOS		0.7 × V <sub>DD</sub>			V
V <sub>I(thresh)</sub>	Input voltage threshold LVCMOS			0.5 × V <sub>DD</sub>		V
V <sub>IS</sub>	Input voltage range S0		0		1.9	V
	Input voltage range S1, S2, SDA, SCL	V <sub>Ithresh</sub> = 0.5 V <sub>DD</sub>	0		3.6	
V <sub>ICLK</sub>	Input voltage range CLK		0		1.9	V
I <sub>OH</sub> /I <sub>OL</sub>	Output current	V <sub>DDout</sub> = 3.3 V			±12	mA
		V <sub>DDout</sub> = 2.5 V			±10	mA
		V <sub>DDout</sub> = 1.8 V			±8	mA
C <sub>L</sub>	Output load LVCMOS				10	pF
T <sub>A</sub>	Operating free-air temperature		−40		85	°C

## RECOMMENDED CRYSTAL/VCXO SPECIFICATIONS<sup>(1)</sup>

		MIN	NOM	MAX	UNIT
f <sub>Xtal</sub>	Crystal Input frequency range (fundamental mode)	8	27	32	MHz
ESR	Effective series resistance			100	Ω
f <sub>PR</sub>	Pulling range (0 V ≤ V <sub>Ctrl</sub> ≤ 1.8 V) <sup>(2)</sup>	±120	±150		ppm
V <sub>(Ctrl)</sub>	Frequency control voltage	0		V <sub>DD</sub>	V
C <sub>0</sub> /C <sub>1</sub>	Pullability ratio			220	
C <sub>L</sub>	On-chip load capacitance at Xin and Xout	0		20	pF

(1) For more information about VCXO configuration and crystal recommendation see application report [SCAA085](#).

(2) Pulling range depends on crystal type, on-chip crystal load capacitance and PCB stray capacitance; pulling range of min ±120 ppm applies for crystal listed in the application report [SCAA085](#).

## EEPROM SPECIFICATION

		MIN	TYP	MAX	UNIT
EEcyc	EEcyc programming cycles of EEPROM	1000			cycles
EEret	EEret data retention	10			years

## TIMING REQUIREMENTS

over recommended ranges of supply voltage, load and operating free-air temperature

CLK_IN Requirements		MIN	NOM	MAX	UNIT	
f <sub>(CLK)</sub>	LVCMOS clock input frequency	PLL Bypass Mode		0	160	MHz
		PLL Mode		8	160	
t <sub>r</sub> / t <sub>f</sub>	Rise and fall time CLK signal (20% to 80%)				3	ns
duty <sub>CLK</sub>	Duty cycle CLK at V <sub>DD</sub> / 2			40%	60%	

SDA/SCL TIMING REQUIREMENTS (see Figure 12)		STANDARD MODE		FAST MODE		UNIT
		MIN	MAX	MIN	MAX	
f <sub>(SCL)</sub>	SCL clock frequency	0	100	0	400	kHz
t <sub>su</sub> (START)	START setup time (SCL high before SDA low)	4.7		0.6		µs
t <sub>h</sub> (START)	START hold time (SCL low after SDA low)	4		0.6		µs
t <sub>w</sub> (SCLL)	SCL low-pulse duration	4.7		1.3		µs
t <sub>w</sub> (SCLH)	SCL high-pulse duration	4		0.6		µs
t <sub>h</sub> (SDA)	SDA hold time (SDA valid after SCL low)	0	3.45	0	0.9	µs
t <sub>su</sub> (SDA)	SDA setup time	250		100		ns
t <sub>r</sub>	SCL/SDA input rise time		1000		300	ns
t <sub>f</sub>	SCL/SDA input fall time		300		300	ns
t <sub>su</sub> (STOP)	STOP setup time	4.0		0.6		µs
t <sub>BUF</sub>	Bus free time between a STOP and START condition	4.7		1.3		µs

## DEVICE CHARACTERISTICS

over recommended operating free-air temperature range (unless otherwise noted)

PARAMETER		TEST CONDITIONS		MIN	TYP <sup>(1)</sup>	MAX	UNIT
<b>OVERALL PARAMETER</b>							
I <sub>DD</sub>	Supply current (see Figure 3)	All outputs off, f <sub>CLK</sub> = 27 MHz, f <sub>VCO</sub> = 135 MHz;	All PLLs on		38		mA
			Per PLL		9		
I <sub>DD(OUT)</sub>	Supply current (see Figure 4 and Figure 5)	No load, all outputs on, f <sub>out</sub> = 27 MHz	CDCE949 V <sub>DDOUT</sub> = 3.3 V		4		mA
			CDCEL949 V <sub>DDOUT</sub> = 1.8 V		2		
I <sub>DD(PD)</sub>	Power down current. Every circuit powered down except SDA/SCL	f <sub>IN</sub> = 0 MHz, V <sub>DD</sub> = 1.9 V			50		µA
V <sub>(PUC)</sub>	Supply voltage V <sub>DD</sub> threshold for power up control circuit			0.85		1.45	V
f <sub>VCO</sub>	VCO frequency range of PLL			80		230	MHz
f <sub>OUT</sub>	LVCMOS output frequency			230			MHz
<b>LVCMOS PARAMETER</b>							
V <sub>IK</sub>	LVCMOS input voltage	V <sub>DD</sub> = 1.7 V; I <sub>I</sub> = -18 mA				-1.2	V
I <sub>I</sub>	LVCMOS input current	V <sub>I</sub> = 0 V or V <sub>DD</sub> ; V <sub>DD</sub> = 1.9 V				±5	µA
I <sub>IH</sub>	LVCMOS input current for S0/S1/S2	V <sub>I</sub> = V <sub>DD</sub> ; V <sub>DD</sub> = 1.9 V				5	µA
I <sub>IL</sub>	LVCMOS input current for S0/S1/S2	V <sub>I</sub> = 0 V; V <sub>DD</sub> = 1.9 V				-4	µA
C <sub>I</sub>	Input capacitance at Xin/Clk	V <sub>ICLK</sub> = 0 V or V <sub>DD</sub>				6	pF
	Input capacitance at Xout	V <sub>IXout</sub> = 0 V or V <sub>DD</sub>				2	
	Input capacitance at S0/S1/S2	V <sub>IS</sub> = 0 V or V <sub>DD</sub>				3	

(1) All typical values are at respective nominal V<sub>DD</sub>.

## DEVICE CHARACTERISTICS (Continued)

over recommended operating free-air temperature range (unless otherwise noted)

PARAMETER		TEST CONDITIONS	MIN	TYP <sup>(1)</sup>	MAX	UNIT
<b>CDCE949 – LVCMOS PARAMETER FOR V<sub>DDOUT</sub> = 3.3 V – MODE</b>						
V <sub>OH</sub>	LVCMOS high-level output voltage	V <sub>DDOUT</sub> = 3 V, I <sub>OH</sub> = –0.1 mA	2.9			V
		V <sub>DDOUT</sub> = 3 V, I <sub>OH</sub> = –8 mA	2.4			
		V <sub>DDOUT</sub> = 3 V, I <sub>OH</sub> = –12 mA	2.2			
V <sub>OL</sub>	LVCMOS low-level output voltage	V <sub>DDOUT</sub> = 3 V, I <sub>OL</sub> = 0.1 mA			0.1	V
		V <sub>DDOUT</sub> = 3 V, I <sub>OL</sub> = 8 mA			0.5	
		V <sub>DDOUT</sub> = 3 V, I <sub>OL</sub> = 12 mA			0.8	
t <sub>PLH</sub> , t <sub>PHL</sub>	Propagation delay	PLL bypass		3.2		ns
t <sub>r</sub> /t <sub>f</sub>	Rise and fall time	V <sub>DDOUT</sub> = 3.3 V (20%–80%)		0.6		ns
t <sub>jit(cc)</sub>	Cycle-to-cycle jitter <sup>(2)(3)</sup>	1 PLL switching, Y2-to-Y3		60	90	ps
		4 PLLs switching, Y2-to-Y9		120	170	
t <sub>jit(per)</sub>	Peak-to-peak period jitter <sup>(2)(3)</sup>	1 PLL switching, Y2-to-Y3		70	100	ps
		4 PLLs switching, Y2-to-Y9		130	180	
t <sub>sk(o)</sub>	Output skew <sup>(4)</sup>	f <sub>OUT</sub> = 50 MHz; Y1-to-Y3			60	ps
		f <sub>OUT</sub> = 50 MHz; Y2-to-Y5 or Y6-to-Y9			160	
odc	Output duty cycle <sup>(5)</sup>	f <sub>VCO</sub> = 100 MHz; Pdiv = 1	45		55	%
<b>CDCE949 – LVCMOS PARAMETER FOR V<sub>DDOUT</sub> = 2.5 V – MODE</b>						
V <sub>OH</sub>	LVCMOS high-level output voltage	V <sub>DDOUT</sub> = 2.3 V, I <sub>OH</sub> = –0.1 mA	2.2			V
		V <sub>DDOUT</sub> = 2.3 V, I <sub>OH</sub> = –6 mA	1.7			
		V <sub>DDOUT</sub> = 2.3 V, I <sub>OH</sub> = –10 mA	1.6			
V <sub>OL</sub>	LVCMOS low-level output voltage	V <sub>DDOUT</sub> = 2.3 V, I <sub>OL</sub> = 0.1 mA			0.1	V
		V <sub>DDOUT</sub> = 2.3 V, I <sub>OL</sub> = 6 mA			0.5	
		V <sub>DDOUT</sub> = 2.3 V, I <sub>OL</sub> = 10 mA			0.7	
t <sub>PLH</sub> , t <sub>PHL</sub>	Propagation delay	PLL bypass		3.4		ns
t <sub>r</sub> /t <sub>f</sub>	Rise and fall time	V <sub>DDOUT</sub> = 2.5 V (20%–80%)		0.8		ns
t <sub>jit(cc)</sub>	Cycle-to-cycle jitter <sup>(2)(3)</sup>	1 PLL switching, Y2-to-Y3		60	90	ps
		4 PLLs switching, Y2-to-Y9		120	170	
t <sub>jit(per)</sub>	Peak-to-peak period jitter <sup>(2)(3)</sup>	1 PLL switching, Y2-to-Y3		70	100	ps
		4 PLLs switching, Y2-to-Y9		130	180	
t <sub>sk(o)</sub>	Output skew <sup>(4)</sup>	f <sub>OUT</sub> = 50 MHz; Y1-to-Y3			60	ps
		f <sub>OUT</sub> = 50 MHz; Y2-to-Y5 or Y6-to-Y9			160	
odc	Output duty cycle <sup>(5)</sup>	f <sub>VCO</sub> = 100 MHz; Pdiv = 1	45		55	%

(1) All typical values are at respective nominal V<sub>DD</sub>.

(2) 10000 cycles.

(3) Jitter depends on device configuration. Data is taken under the following conditions: 1-PLL: f<sub>IN</sub> = 27 MHz, Y2/3 = 27 MHz, (measured at Y2), 4-PLL: f<sub>IN</sub> = 27 MHz, Y2/3 = 27 MHz, (manured at Y2), Y4/5 = 16.384 MHz, Y6/7 = 74.25 MHz, Y8/9 = 48 MHz.

(4) The t<sub>sk(o)</sub> specification is only valid for equal loading of each bank of outputs and outputs are generated from the same divider; data sampled on rising edge (t<sub>r</sub>).

(5) odc depends on output rise- and fall-time (t<sub>r</sub>/t<sub>f</sub>).

## DEVICE CHARACTERISTICS (Continued)

over recommended operating free-air temperature range (unless otherwise noted)

PARAMETER		TEST CONDITIONS	MIN	TYP <sup>(1)</sup>	MAX	UNIT
<b>SAVE THIS CDCEL949 – LVCMOS PARAMETER FOR V<sub>DDOUT</sub> = 1.8 V – MODE</b>						
V <sub>OH</sub>	LVCMOS high-level output voltage	V <sub>DDOUT</sub> = 1.7 V, I <sub>OH</sub> = –0.1 mA	1.6			V
		V <sub>DDOUT</sub> = 1.7 V, I <sub>OH</sub> = –4 mA	1.4			
		V <sub>DDOUT</sub> = 1.7 V, I <sub>OH</sub> = –8 mA	1.1			
V <sub>OL</sub>	LVCMOS low-level output voltage	V <sub>DDOUT</sub> = 1.7 V, I <sub>OL</sub> = 0.1 mA			0.1	V
		V <sub>DDOUT</sub> = 1.7 V, I <sub>OL</sub> = 4 mA			0.3	
		V <sub>DDOUT</sub> = 1.7 V, I <sub>OL</sub> = 8 mA			0.6	
t <sub>PLH</sub> , t <sub>PHL</sub>	Propagation delay	PLL bypass		2.6		ns
t <sub>r</sub> /t <sub>f</sub>	Rise and fall time	V <sub>DDOUT</sub> = 1.8 V (20%–80%)		0.7		ns
t <sub>jitter(cc)</sub>	Cycle-to-cycle jitter <sup>(2)</sup> (3)	1 PLL switching, Y2-to-Y3		70	120	ps
		4 PLLs switching, Y2-to-Y9		120	170	
t <sub>jitter(per)</sub>	Peak-to-peak period jitter <sup>(2)(3)</sup>	1 PLL switching, Y2-to-Y3		90	140	ps
		4 PLLs switching, Y2-to-Y9		130	190	
t <sub>sk(o)</sub>	Output skew <sup>(4)</sup>	f <sub>OUT</sub> = 50 MHz; Y1-to-Y3			60	ps
		f <sub>OUT</sub> = 50 MHz; Y2-to-Y5 or Y6-to-Y9			160	
odc	Output duty cycle <sup>(5)</sup>	f <sub>VCO</sub> = 100 MHz; Pdiv = 1	45		55	%
<b>SDA/SCL PARAMETER</b>						
V <sub>IK</sub>	SCL and SDA input clamp voltage	V <sub>DD</sub> = 1.7 V; I <sub>I</sub> = –18 mA			–1.2	V
I <sub>IH</sub>	SCL and SDA input current	V <sub>I</sub> = V <sub>DD</sub> ; V <sub>DD</sub> = 1.9 V			±10	μA
V <sub>IH</sub>	SDA/SCL input high voltage <sup>(6)</sup>		0.7 V <sub>DD</sub>			V
V <sub>IL</sub>	SDA/SCL input low voltage <sup>(6)</sup>				0.3 V <sub>DD</sub>	V
V <sub>OL</sub>	SDA low-level output voltage	I <sub>OL</sub> = 3 mA, V <sub>DD</sub> = 1.7 V			0.2 V <sub>DD</sub>	V
C <sub>I</sub>	SCL/SDA input capacitance	V <sub>I</sub> = 0 V or V <sub>DD</sub>		3	10	pF

(1) All typical values are at respective nominal V<sub>DD</sub>.

(2) 10000 cycles.

(3) Jitter depends on device configuration. Data is taken under the following conditions: 1-PLL: f<sub>IN</sub> = 27 MHz, Y2/3 = 27 MHz, (measured at Y2), 4-PLL: f<sub>IN</sub> = 27 MHz, Y2/3 = 27 MHz, (measured at Y2), Y4/5 = 16.384 MHz, Y6/7 = 74.25 MHz, Y8/9 = 48 MHz.

(4) The t<sub>sk(o)</sub> specification is only valid for equal loading of each bank of outputs and outputs are generated from same divider; data sampled on rising edge (t<sub>r</sub>).

(5) odc depends on output rise- and fall-time (t<sub>r</sub>/t<sub>f</sub>).

(6) SDA and SCL pins are 3.3-V tolerant.

## PARAMETER MEASUREMENT INFORMATION

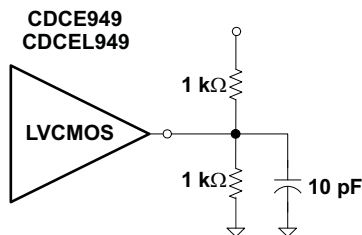

Figure 1. Test Load

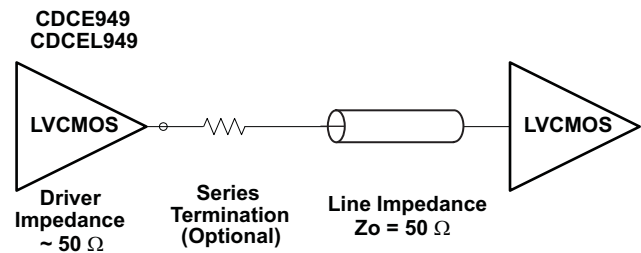

Figure 2. Test Load for 50 Ω Board Environment

TYPICAL CHARACTERISTICS

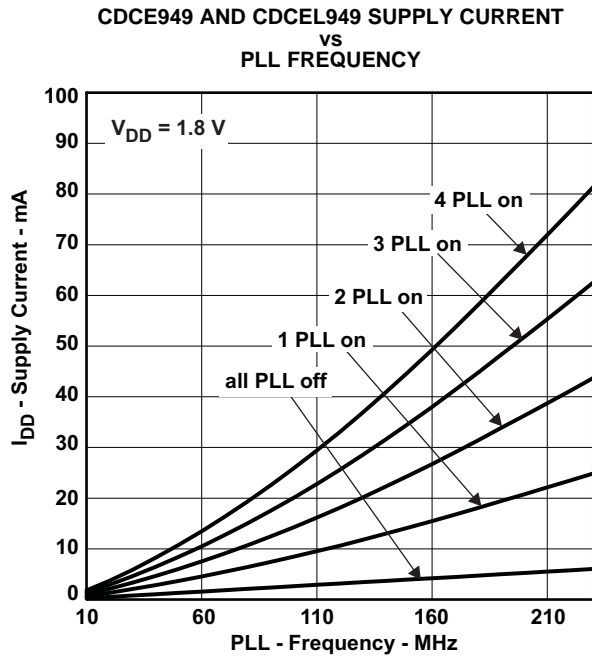

Figure 3.

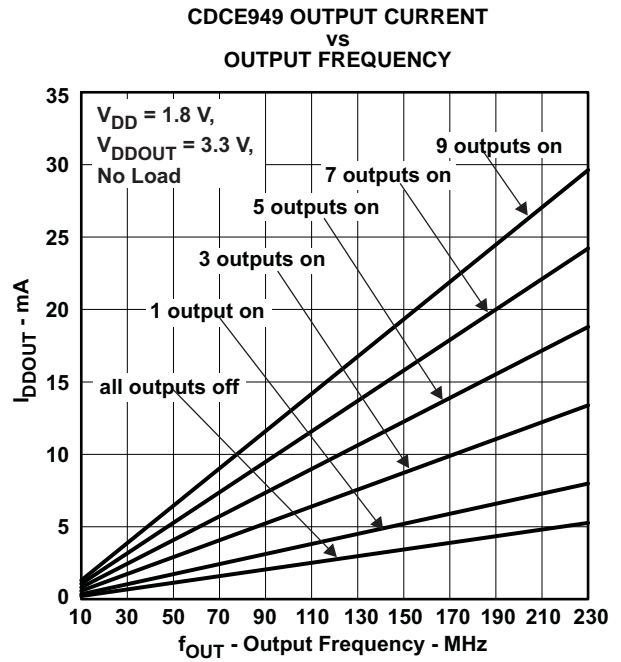

Figure 4.

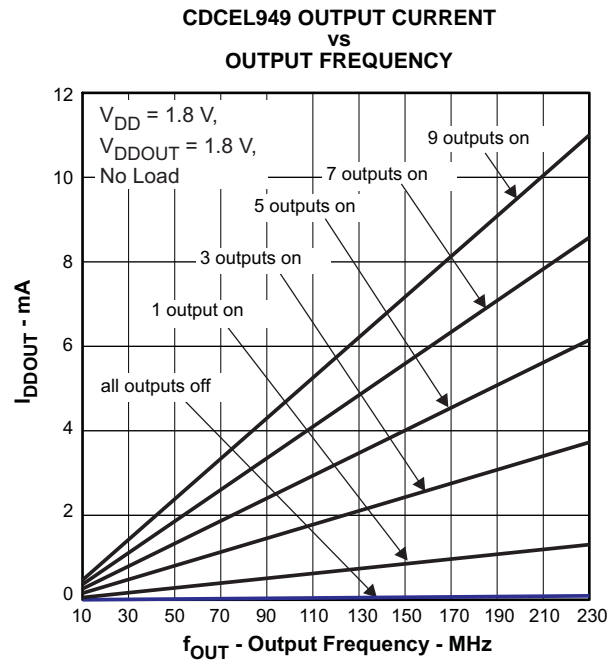

Figure 5.

## APPLICATION INFORMATION

### Control Terminal Configuration

The CDCE949/CDCEL949 has three user-definable control terminals (S0, S1 and S2) which allow external control of device settings. They can be programmed to perform any of the following functions:

- Spread-Spectrum Clocking selection: Spread-type and spread-amount selection
- Frequency selection: Switching between any of two user-defined frequencies
- Output-State selection: Output configuration and power-down control

The user can predefine up to eight different control settings. [Table 1](#) and [Table 2](#) explain these settings.

**Table 1. Control Terminal Definition**

External Control-Bits	PLL1 Setting			PLL2 Setting			PLL3 Setting			PLL4 Setting			Y1 Setting
Control Function	PLL Frequency Selection	SSC Selection	Output Y2/Y3 Selection	PLL Frequency Selection	SSC Selection	Output Y4/Y5 Selection	PLL Frequency Selection	SSC Selection	Output Y6/Y7 Selection	PLL Frequency Selection	SSC Selection	Output Y8/Y9 Selection	Output Y1 and Power Down Selection

**Table 2. PLLx Setting (can be selected for each PLL individual)<sup>(1)</sup>**

SSC Selection (Center/Down)				
SSCx [3-bits]			Center	Down
0	0	0	0% (off)	0% (off)
0	0	1	±0.25%	-0.25%
0	1	0	±0.5%	-0.5%
0	1	1	±0.75%	-0.75%
1	0	0	±1.0%	-1.0%
1	0	1	±1.25%	-1.25%
1	1	0	±1.5%	-1.5%
1	1	1	±2.0%	-2.0%
FREQUENCY SELECTION <sup>(2)</sup>				
FSx		FUNCTION		
0		Frequency0		
1		Frequency1		
OUTPUT SELECTION <sup>(3)</sup> (Y2 ... Y9)				
YxYx		FUNCTION		
0		State0		
1		State1		

(1) Center/Down-Spread, Frequency0/1 and State0/1 are user-definable in PLLx Configuration Register;

(2) Frequency0 and Frequency1 can be any frequency within the specified  $f_{VCO}$  range.

(3) State0/1 selection is valid for both outputs of the corresponding PLL module and can be power down, 3-state, low or active

Table 3. Y1 Setting<sup>(1)</sup>

Y1 SELECTION	
Y1	FUNCTION
0	State 0
1	State 1

(1) State0 and State1 are user-definable in Generic Configuration Register and can be power down, 3-state, low or active.

The S1/SDA and S2/SCL pins of the CDCE949/CDCEL949 are dual-function pins. In the default configuration they are defined as SDA/SCL for the serial interface. They can be programmed as control pins (S1/S2) by setting the appropriate bits in the EEPROM. Note that changes to the Control register (Bit [6] of Byte 02) have no effect until they are written into the EEPROM.

Once they are set as control pins, the serial programming interface is no longer available. However, if  $V_{DDOUT}$  is forced to GND, the two control-pins, S1 and S2, temporarily act as serial programming pins (SDA/SCL).

S0 is **not** a multi-use pin, it is a control pin only.

### DEFAULT DEVICE SETTING

The internal EEPROM of CDCE949/CDCEL949 is preconfigured as shown in Figure 6. (The input frequency is passed through to the output as a default.) This allows the device to operate in default mode without the extra production step of programming it. The default setting appears after power is supplied or after a power-down/up sequence until it is reprogrammed by the user to a different application configuration. A new register setting is programmed via the serial SDA/SCL Interface.

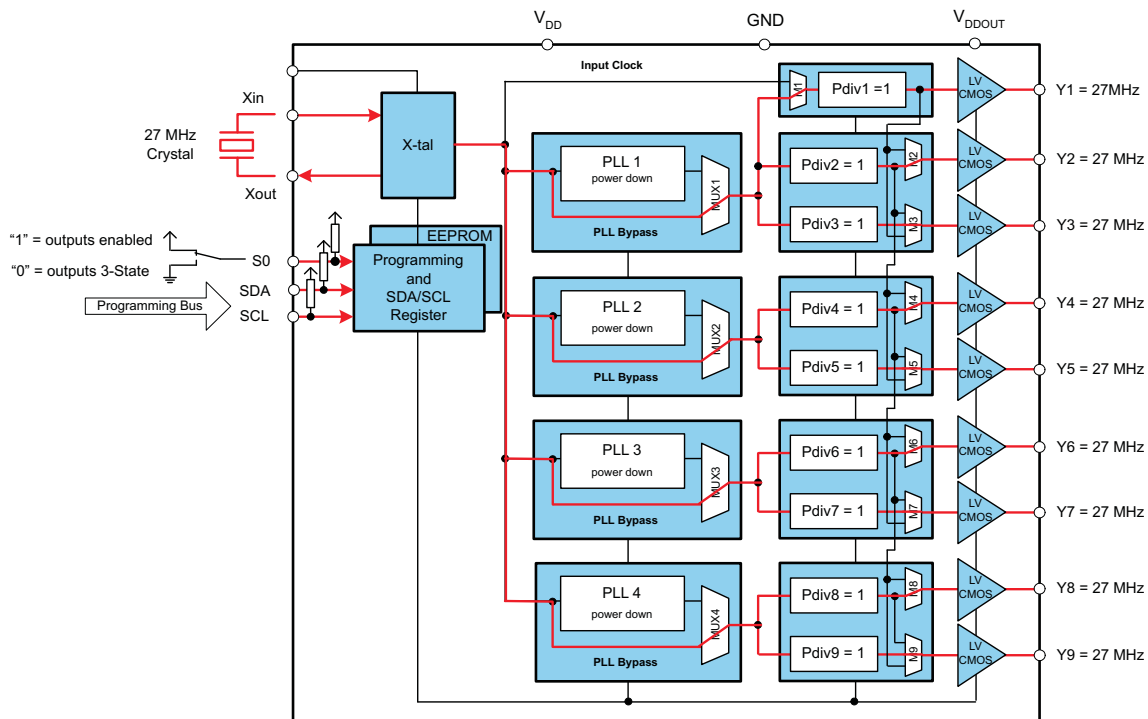

Figure 6. Default Configuration

A different default setting can be programmed upon customer request. Contact Texas Instruments sales or marketing representative for more information.

Table 4 shows the default setting for the Control Terminal Register (external control pins). In normal operation, all 8 register settings are available, but in the default configuration only the first two settings (0 and 1) can be selected with S0, as S1 and S2 are configured as programming pins in default mode.

**Table 4. Factory Default Setting for Control Terminal Register**

EXTERNAL CONTROL-PINS <sup>(1)</sup>			Y1	PLL1 SETTING			PLL2 SETTING			PLL3 SETTING			PLL4 SETTING		
			Output Select	Freq. Select	SSC Sel.	Output Select	Freq. Select	SSC Sel.	Output Select	Freq. Select	SSC Sel.	Output Select	Freq. Select	SSC Sel.	Output Select
S2	S1	S0	Y1	FS1	SSC1	Y2Y3	FS2	SSC2	Y4Y5	FS3	SSC3	Y6Y7	FS4	SSC4	Y8Y9
SCL (I <sup>2</sup> C)	SDA (I <sup>2</sup> C)	0	3-State	f <sub>VC01_0</sub>	off	3-State	f <sub>VC02_0</sub>	off	3-State	f <sub>VC03_0</sub>	off	3-State	f <sub>VC04_0</sub>	off	3-State
SCL (I <sup>2</sup> C)	SDA (I <sup>2</sup> C)	1	enabled	f <sub>VC01_0</sub>	off	enabled	f <sub>VC02_0</sub>	off	enabled	f <sub>VC03_0</sub>	off	enabled	f <sub>VC04_0</sub>	off	enabled

(1) In default mode or when programmed respectively, S1 and S2 act as a serial programming interface, SDA/SCL. In this mode, they have no control-pin function, but are internally interpreted as if S1=0 and S2=0. S0, however, is a control-pin which in the default mode switches all outputs ON or OFF (as pre-defined above).

## SDA/SCL SERIAL INTERFACE

The CDCE949/CDCEL949 operates as a slave device on the 2-wire serial SDA/SCL bus, compatible with the popular SMBus or I<sup>2</sup>C™ specification. It operates in the standard-mode transfer (up to 100 kbps) and fast-mode transfer (up to 400 kbps) and supports 7-bit addressing.

The S1/SDA and S2/SCL pins of the CDC9xx are dual-function pins. In the default configuration they are used as SDA/SCL serial programming interface. They can be reprogrammed as general purpose control pins, S1 and S2, by changing the corresponding EEPROM setting, Byte 02, Bit [6].

## DATA PROTOCOL

The device supports *Byte Write and Byte Read* and *Block Write and Block Read* operations.

For *Byte Write/Read* operations, the system controller can individually access addressed bytes.

For *Block Write/Read* operations, the bytes are accessed in sequential order from lowest to highest byte (with most significant bit first) with the ability to stop after any complete byte has been transferred. The number of bytes read out is defined by the Byte Count field in the Generic Configuration Register. During a Block Read instruction, the entire number of bytes defined in Byte Count must be read out to correctly finish the read cycle.

When a byte is sent to the device, it is written into the internal register and immediately takes effect. This applies to each transferred byte, whether in a *Byte Write* or a *Block Write* sequence.

If the EEPROM Write Cycle is initiated, the internal SDA register contents are written into the EEPROM. During this write cycle, data is not accepted at the SDA/SCL bus until the write cycle is completed. However, data can be read during the programming sequence (Byte Read or Block Read). The programming status can be monitored by reading *EEPIP*, Byte 01–Bit [6].

The offset of the indexed byte is encoded in the command code, as described in [Table 6](#).

**Table 5. Slave Receiver Address (7 bits)**

Device	A6	A5	A4	A3	A2	A1 <sup>(1)</sup>	A0 <sup>(1)</sup>	R/W
CDCE913/CDCEL913	1	1	0	0	1	0	1	1/0
CDCE925/CDCEL925	1	1	0	0	1	0	0	1/0
CDCE937/CDCEL937	1	1	0	1	1	0	1	1/0
<b>CDCE949/CDCEL949</b>	<b>1</b>	<b>1</b>	<b>0</b>	<b>1</b>	<b>1</b>	<b>0</b>	<b>0</b>	<b>1/0</b>

(1) Address bits A0 and A1 are programmable via the SDA/SCL bus (Byte 01, Bit [1:0]). This allows addressing up to 4 devices connected to the same SDA/SCL bus. The least significant bit of the address byte designates a write or read operation.

**Table 6. Command Code Definition**

BIT	DESCRIPTION
7	0 = <i>Block Read</i> or <i>Block Write</i> operation 1 = <i>Byte Read</i> or <i>Byte Write</i> operation
(6:0)	Byte Offset for <i>Byte Read</i> , <i>Block Read</i> , <i>Byte Write</i> and <i>Block Write</i> operation.

**Generic Programming Sequence**

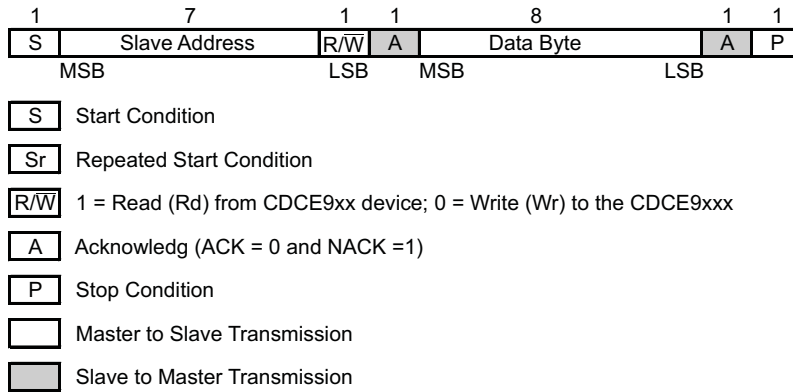

**Figure 7. Generic Programming Sequence**

**Byte Write Programming Sequence**

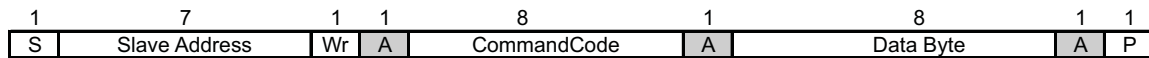

**Figure 8. Byte Write Protocol**

**Byte Read Programming Sequence**

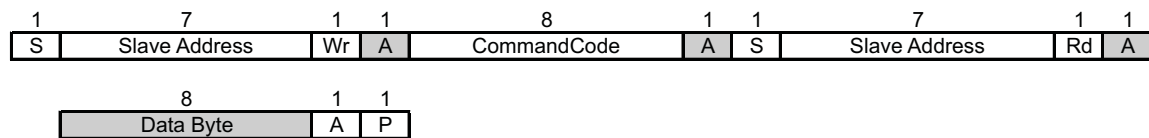

**Figure 9. Byte Read Protocol**

**Block Write Programming Sequence**

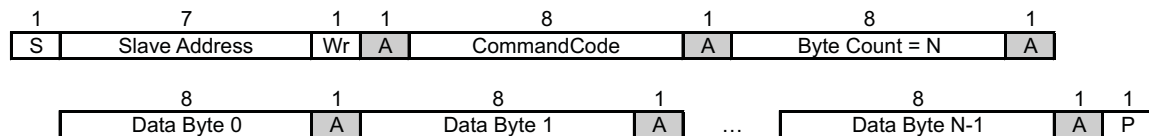

NOTE: Data Byte 0 Bits [7:0] is reserved for Revision Code and Vendor Identification. Also it is used for internal test purpose and should not be overwritten.

**Figure 10. Block Write Programming**

### Block Read Programming Sequence

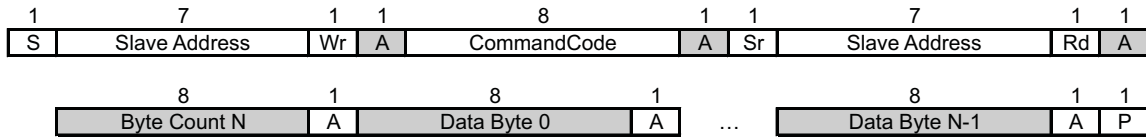

Figure 11. Block Read Protocol

### Timing Diagram for the SDA/SCL Serial Control Interface

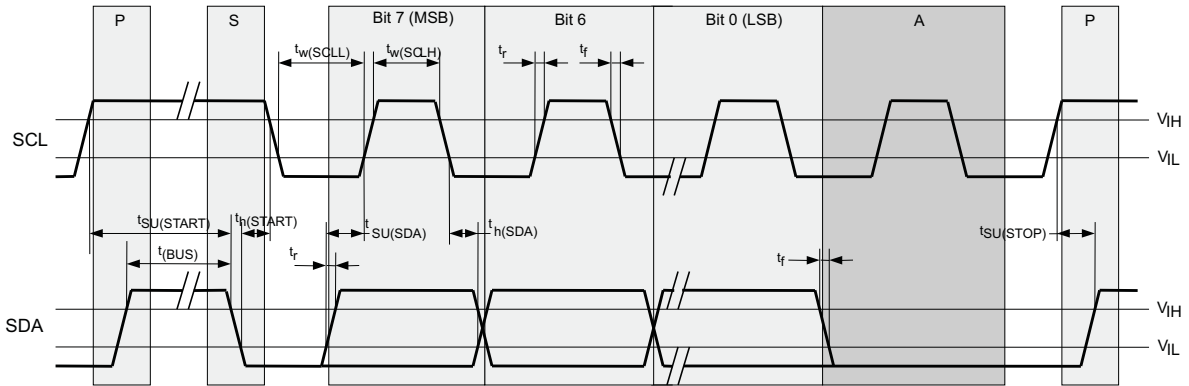

Figure 12. Timing Diagram for the SDA/SCL Serial Control Interface

### SDA/SCL Hardware Interface

Figure 13 shows how the CDCE949/CDCEL949 clock synthesizer is connected to the SDA/SCL serial interface bus. Multiple devices can be connected to the bus but the speed may need to be reduced (400 kHz is the maximum) if many devices are connected.

Note that the pull-up resistor value ( $R_p$ ) depends on the supply voltage, bus capacitance and number of connected devices. The recommended pull-up value is 4.7 k $\Omega$ . It must meet the minimum sink current of 3 mA at  $V_{OLmax} = 0.4$  V for the output stages (for more details see the SMBus or I<sup>2</sup>C Bus specification).

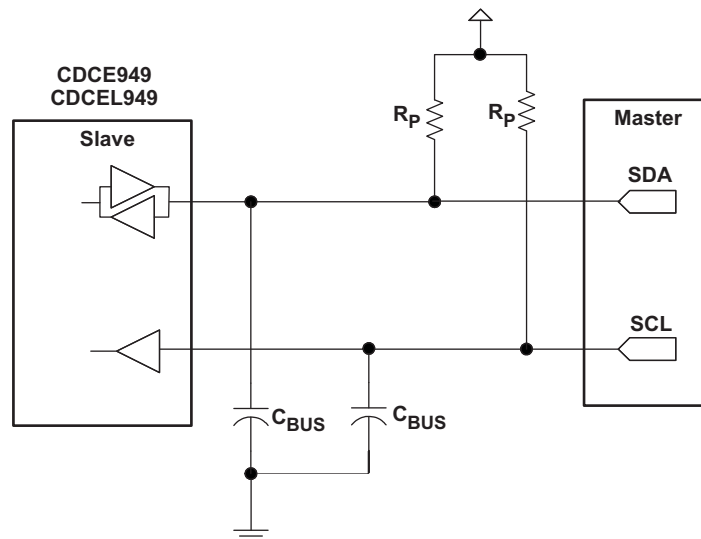

Figure 13. SDA/SCL Hardware Interface

## SDA/SCL CONFIGURATION REGISTERS

The clock input, control pins, PLLs and output stages are user configurable. The following tables and explanations describe the programmable functions of the CDCE949/CDCEL949. All settings can be manually written to the device via the SDA/SCL bus, or are easily programmable by using the TI Pro Clock software. TI Pro Clock software allows the user to quickly make all settings and automatically calculates the values for optimized performance at lowest jitter.

**Table 7. SDA/SCL Registers**

ADDRESS OFFSET	REGISTER DESCRIPTION	TABLE
00h	Generic Configuration Register	<a href="#">Table 9</a>
10h	PLL1 Configuration Register	<a href="#">Table 10</a>
20h	PLL2 Configuration Register	<a href="#">Table 11</a>
30h	PLL3 Configuration Register	<a href="#">Table 12</a>
40h	PLL4 Configuration Register	<a href="#">Table 13</a>

The grey-highlighted Bits described in the Configuration Registers tables on the following pages, belong to the Control Terminal Register. The user can predefine up to eight different control settings. These settings can then be selected by the external control pins, S0, S1, and S2 (See the [Control Terminal Configuration](#) section).

**Table 8. Configuration Register, External Control Terminals**

EXTERNAL CONTROL PINS			Y1	PLL1 SETTING			PLL2 SETTING			PLL3 SETTING			PLL4 SETTING		
			Output Select	Freq. Select	SSC Select	Output Select	Freq. Select	SSC Select	Output Select	Freq. Select	SSC Select	Output Select	Freq. Select	SSC Select	Output Select
S2	S1	S0	Y1	FS1	SSC1	Y2Y3	FS2	SSC2	Y4Y5	FS3	SSC3	Y6Y7	FS4	SSC4	Y8Y9
0	0	0	Y1_0	FS1_0	SSC1_0	Y2Y3_0	FS2_0	SSC2_0	Y4Y5_0	FS3_0	SSC3_0	Y6Y7_0	FS4_0	SSC4_0	Y8Y9_0
0	0	1	Y1_1	FS1_1	SSC1_1	Y2Y3_1	FS2_1	SSC2_1	Y4Y5_1	FS3_1	SSC3_1	Y6Y7_1	FS4_1	SSC4_1	Y8Y9_1
0	1	0	Y1_2	FS1_2	SSC1_2	Y2Y3_2	FS2_2	SSC2_2	Y4Y5_2	FS3_2	SSC3_2	Y6Y7_2	FS4_2	SSC4_2	Y8Y9_2
0	1	1	Y1_3	FS1_3	SSC1_3	Y2Y3_3	FS2_3	SSC2_3	Y4Y5_3	FS3_3	SSC3_3	Y6Y7_3	FS4_3	SSC4_3	Y8Y9_3
1	0	0	Y1_4	FS1_4	SSC1_4	Y2Y3_4	FS2_4	SSC2_4	Y4Y5_4	FS3_4	SSC3_4	Y6Y7_4	FS4_4	SSC4_4	Y8Y9_4
1	0	1	Y1_5	FS1_5	SSC1_5	Y2Y3_5	FS2_5	SSC2_5	Y4Y5_5	FS3_5	SSC3_5	Y6Y7_5	FS4_5	SSC4_5	Y8Y9_5
1	1	0	Y1_6	FS1_6	SSC1_6	Y2Y3_6	FS2_6	SSC2_6	Y4Y5_6	FS3_6	SSC3_6	Y6Y7_6	FS4_6	SSC4_6	Y8Y9_6
1	1	1	Y1_7	FS1_7	SSC1_7	Y2Y3_7	FS2_7	SSC2_7	Y4Y5_7	FS3_7	SSC3_7	Y6Y7_7	FS4_7	SSC4_7	Y8Y9_7
Addr. Offset <sup>(1)</sup>			04h	13h	10h-12h	15h	23h	20h-22h	25h	33h	30h-32h	35h	43h	40h-42h	45h

(1) Address Offset refers to the byte address in the Configuration Register on following pages.

Table 9. Generic Configuration Register

OFFSET <sup>(1)</sup>	Bit <sup>(2)</sup>	Acronym	Default <sup>(3)</sup>	DESCRIPTION
00h	7	E_EL	xb	Device Identification (read only): '1' is CDCE949 (3.3V), '0' is CDCEL949 (1.8V)
	6:4	RID	0h	Revision Identification Number (read only)
	3:0	VID	1h	Vendor Identification Number (read only)
01h	7	–	0b	Reserved - always write 0
	6	EEPIP	0b	EEPROM Programming Status <sup>(4)</sup> : (read only) 0 – EEPROM programming is completed 1 – EEPROM is in programming mode
	5	EELOCK	0b	Permanently Lock EEPROM Data <sup>(5)</sup> : 0 – EEPROM is not locked 1 – EEPROM will be permanently locked
	4	PWDN	0b	Device power down (overwrites S0/S1/S2 setting; configuration register settings are unchanged) 0 – device active (all PLLs and all outputs are enabled) 1 – device power down (all PLLs in power down and all outputs in 3-State)
	3:2	INCLK	00b	Input clock selection: 00 – X-tal                      10 – LVCMOS 01 – VCXO                      11 – reserved
	1:0	SLAVE_ADR	00b	Programmable Address Bits A0 and A1 of the Slave Receiver Address
02h	7	M1	1b	Clock source selection for output Y1: 0 – input clock 1 – PLL1 clock
	6	SPICON	0b	Operation mode selection for pin 22/23 <sup>(6)</sup> 0 – serial programming interface SDA (pin 23) and SCL (pin 22) 1 – control pins S1 (pin 23) and S2 (pin 22)
	5:4	Y1_ST1	11b	Y1-State0/1 Definition (applies to Y1_ST1 and Y1_ST0)
	3:2	Y1_ST0	01b	00 – device power down (all PLLs in power down and all outputs in 3-state) 01 – Y1 disabled to 3-state 10 – Y1 disabled to low 11 – Y1 enabled (normal operation)
	1:0	Pdiv1 [9:8]	001h	10-Bit Y1-Output-Divider Pdiv1: 0 – divider reset and stand-by 1-to-1023 – divider value
03h	7:0	Pdiv1 [7:0]		
04h	7	Y1_7	0b	Y1_x State Selection <sup>(7)</sup> 0 – State0 (predefined by Y1-State0 Definition [Y1_ST0]) 1 – State1 (predefined by Y1-State1 Definition [Y1_ST1])
	6	Y1_6	0b	
	5	Y1_5	0b	
	4	Y1_4	0b	
	3	Y1_3	0b	
	2	Y1_2	0b	
	1	Y1_1	1b	
	0	Y1_0	0b	
05h	7:3	XCSEL	0Ah	Crystal load capacitor selection <sup>(8)</sup> : 00h → 0 pF 01h → 1 pF 02h → 2 pF 14h-to-1Fh → 20 pF
	2:0	—	0b	Reserved - do not write others than 0

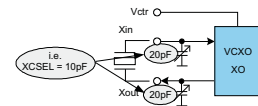

- (1) Writing data beyond '50h' may adversely affect device function.
- (2) All data is transferred MSB-first.
- (3) Unless custom setting is used.
- (4) During EEPROM programming, no data is allowed to be sent to the device via the SDA/SCL bus until the programming sequence is completed. Data, however, can be read during the programming sequence (Byte Read or Block Read).
- (5) If this bit is set high in the EEPROM, the actual data in the EEPROM is permanently locked, and no further programming is possible. Data, however can still be written via SDA/SCL bus to the internal register to change device function on the fly. But new data can no longer be saved to the EEPROM. EELOCK is effective only if written into the EEPROM
- (6) Selection of *control-pins* is effective only if written into the EEPROM. Once written into the EEPROM, the serial programming pins are no longer available. However, if V<sub>DDOUT</sub> is forced to GND, the two control-pins, S1 and S2, temporarily act as serial programming pins (SDA/SCL), and the two slave receiver address bits are reset to A0 = 0 and A1 = 0.
- (7) These are the bits of the Control Terminal Register. The user can pre-define up to eight different control settings. These settings can then be selected by the external control pins, S0, S1, and S2.
- (8) The internal load capacitor (C<sub>1</sub>, C<sub>2</sub>) must be used to achieve the best clock performance. External capacitors should be used only to do a fine adjustment of C<sub>L</sub> by few pF. The value of C<sub>L</sub> can be programmed with a resolution of 1 pF for a total crystal load range of 0 pF to 20 pF. For C<sub>L</sub> > 20 pF use additional external capacitors. Also, the device input capacitance must be considered; this adds 1.5 pF (6pF//2pF) to the selected C<sub>L</sub>. For more information about VCXO configuration and crystal recommendations, see application report [SCAA085](#)

**Table 9. Generic Configuration Register (continued)**

OFFSET <sup>(1)</sup>	Bit <sup>(2)</sup>	Acronym	Default <sup>(3)</sup>	DESCRIPTION
06h	7:1	BCOUNT	50h	7-Bit Byte Count (Defines the number of Bytes which will be sent from this device at the next Block Read transfer; all bytes must be read out to correctly finish the read cycle.)
	0	EEWRITE	0b	Initiate EEPROM Write Cycle <sup>(4)</sup> <sup>(9)</sup> 0 – no EEPROM write cycle 1 – start EEPROM write cycle (internal configuration register are saved to the EEPROM)
07h-0Fh	—	—	0h	Reserved – do not write others than 0

- (9) **NOTE: The EEPROM WRITE bit must be sent last.** This ensures that the content of all internal registers are written into the EEPROM. The EEWRITE cycle is initiated by the rising edge of the EEWRITE-Bit. A static level high does not trigger an EEPROM WRITE cycle. The EEWRITE-Bit must be reset low after the programming is completed. The programming status can be monitored by readout EEPIP. If EELOCK is set high, no EEPROM programming will be possible.

Table 10. PLL1 Configuration Register

OFFSET <sup>(1)</sup>	Bit <sup>(2)</sup>	Acronym	Default <sup>(3)</sup>	DESCRIPTION																		
10h	7:5	SSC1_7 [2:0]	000b	SSC1: PLL1 SSC Selection (Modulation Amount) <sup>(4)</sup>  <table style="width: 100%; border: none;"> <tr> <td style="width: 50%;"><b>Down</b></td> <td style="width: 50%;"><b>Center</b></td> </tr> <tr> <td>000 (off)</td> <td>000 (off)</td> </tr> <tr> <td>001 – 0.25%</td> <td>001 ± 0.25%</td> </tr> <tr> <td>010 – 0.5%</td> <td>010 ± 0.5%</td> </tr> <tr> <td>011 – 0.75%</td> <td>011 ± 0.75%</td> </tr> <tr> <td>100 – 1.0%</td> <td>100 ± 1.0%</td> </tr> <tr> <td>101 – 1.25%</td> <td>101 ± 1.25%</td> </tr> <tr> <td>110 – 1.5%</td> <td>110 ± 1.5%</td> </tr> <tr> <td>111 – 2.0%</td> <td>111 ± 2.0%</td> </tr> </table>	<b>Down</b>	<b>Center</b>	000 (off)	000 (off)	001 – 0.25%	001 ± 0.25%	010 – 0.5%	010 ± 0.5%	011 – 0.75%	011 ± 0.75%	100 – 1.0%	100 ± 1.0%	101 – 1.25%	101 ± 1.25%	110 – 1.5%	110 ± 1.5%	111 – 2.0%	111 ± 2.0%
	<b>Down</b>	<b>Center</b>																				
	000 (off)	000 (off)																				
001 – 0.25%	001 ± 0.25%																					
010 – 0.5%	010 ± 0.5%																					
011 – 0.75%	011 ± 0.75%																					
100 – 1.0%	100 ± 1.0%																					
101 – 1.25%	101 ± 1.25%																					
110 – 1.5%	110 ± 1.5%																					
111 – 2.0%	111 ± 2.0%																					
4:2	SSC1_6 [2:0]	000b																				
1:0	SSC1_5 [2:1]	000b																				
11h	7		SSC1_5 [0]																			
	6:4	SSC1_4 [2:0]	000b																			
12h	3:1	SSC1_3 [2:0]	000b																			
	0	SSC1_2 [2]	000b																			
	7:6	SSC1_2 [1:0]																				
13h	5:3	SSC1_1 [2:0]	000b																			
	2:0	SSC1_0 [2:0]	000b																			
	14h	7	FS1_7	0b	FS1_x: PLL1 Frequency Selection <sup>(4)</sup>  0 – $f_{VCO1,0}$ (predefined by PLL1_0 – Multiplier/Divider value) 1 – $f_{VCO1,1}$ (predefined by PLL1_1 – Multiplier/Divider value)																	
6		FS1_6	0b																			
5		FS1_5	0b																			
4		FS1_4	0b																			
3		FS1_3	0b																			
2		FS1_2	0b																			
1		FS1_1	0b																			
0		FS1_0	0b																			
15h	7	MUX1	1b	PLL1 Multiplexer: 0 – PLL1 1 – PLL1 Bypass (PLL1 is in power down)																		
	6	M2	1b	Output Y2 Multiplexer: 0 – Pdiv1 1 – Pdiv2																		
	5:4	M3	10b	Output Y3 Multiplexer: 00 – Pdiv1-Divider 01 – Pdiv2-Divider 10 – Pdiv3-Divider 11 – reserved																		
	3:2	Y2Y3_ST1	11b	Y2, Y3-State0/1definition: 00 – Y2/Y3 disabled to 3-State (PLL1 is in power down) 01 – Y2/Y3 disabled to 3-State (PLL1 on) 10–Y2/Y3 disabled to low (PLL1 on) 11 – Y2/Y3 enabled (normal operation, PLL1 on)																		
	1:0	Y2Y3_ST0	01b																			
16h	7	Y2Y3_7	0b	Y2Y3_x Output State Selection <sup>(4)</sup>  0 – state0 (predefined by Y2Y3_ST0) 1 – state1 (predefined by Y2Y3_ST1)																		
	6	Y2Y3_6	0b																			
	5	Y2Y3_5	0b																			
	4	Y2Y3_4	0b																			
	3	Y2Y3_3	0b																			
	2	Y2Y3_2	0b																			
	1	Y2Y3_1	1b																			
	0	Y2Y3_0	0b																			
17h	7	SSC1DC	0b	PLL1 SSC down/center selection: 0 – down 1 – center																		
	6:0	Pdiv2	01h	7-Bit Y2-Output-Divider Pdiv2: 0 – reset and stand-by 1-to-127 – divider value																		
17h	7	—	0b	Reserved – do not write others than 0																		
	6:0	Pdiv3	01h	7-Bit Y3-Output-Divider Pdiv3: 0 – reset and stand-by 1-to-127 – divider value																		

(1) Writing data beyond 50h may adversely affect device function.

(2) All data is transferred MSB-first.

(3) Unless a custom setting is used

(4) The user can pre-define up to eight different control settings. In normal device operation, these settings can be selected by the external control pins, S0, S1, and S2.

**Table 10. PLL1 Configuration Register (continued)**

OFFSET <sup>(1)</sup>	Bit <sup>(2)</sup>	Acronym	Default <sup>(3)</sup>	DESCRIPTION	
18h	7:0	PLL1_0N [11:4]	004h	PLL1_0: 30-Bit Multiplier/Divider value for frequency $f_{VCO1_0}$ (for more information see <a href="#">PLL Multiplier/Divider Definition</a> )	
19h	7:4	PLL1_0N [3:0]			
1Ah	3:0	PLL1_0R [8:5]	000h		
	7:3	PLL1_0R[4:0]	10h		
1Bh	2:0	PLL1_0Q [5:3]			010b
	7:5	PLL1_0Q [2:0]			
	4:2	PLL1_0P [2:0]			
	1:0	VCO1_0_RANGE	00b		$f_{VCO1_0}$ range selection: 00 – $f_{VCO1_0} < 125$ MHz 01 – $125 \text{ MHz} \leq f_{VCO1_0} < 150$ MHz 10 – $150 \text{ MHz} \leq f_{VCO1_0} < 175$ MHz 11 – $f_{VCO1_0} \geq 175$ MHz
1Ch	7:0	PLL1_1N [11:4]	004h		PLL1_1: 30-Bit Multiplier/Divider value for frequency $f_{VCO1_1}$ (for more information see paragraph <a href="#">PLL Multiplier/Divider Definition</a> )
1Dh	7:4	PLL1_1N [3:0]			
1Eh	3:0	PLL1_1R [8:5]	000h		
	7:3	PLL1_1R[4:0]	10h		
1Fh	2:0	PLL1_1Q [5:3]		010b	
	7:5	PLL1_1Q [2:0]			
	4:2	PLL1_1P [2:0]			
	1:0	VCO1_1_RANGE	00b	$f_{VCO1_1}$ range selection: 00 – $f_{VCO1_1} < 125$ MHz 01 – $125 \text{ MHz} \leq f_{VCO1_1} < 150$ MHz 10 – $150 \text{ MHz} \leq f_{VCO1_1} < 175$ MHz 11 – $f_{VCO1_1} \geq 175$ MHz	

Table 11. PLL2 Configuration Register

OFFSET <sup>(1)</sup>	Bit <sup>(2)</sup>	Acronym	Default <sup>(3)</sup>	DESCRIPTION																		
20h	7:5	SSC2_7 [2:0]	000b	SSC2: PLL2 SSC Selection (Modulation Amount) <sup>(4)</sup>  <table style="width: 100%; border: none;"> <tr> <td style="width: 50%;"><b>Down</b></td> <td style="width: 50%;"><b>Center</b></td> </tr> <tr> <td>000 (off)</td> <td>000 (off)</td> </tr> <tr> <td>001 – 0.25%</td> <td>001 ± 0.25%</td> </tr> <tr> <td>010 – 0.5%</td> <td>010 ± 0.5%</td> </tr> <tr> <td>011 – 0.75%</td> <td>011 ± 0.75%</td> </tr> <tr> <td>100 – 1.0%</td> <td>100 ± 1.0%</td> </tr> <tr> <td>101 – 1.25%</td> <td>101 ± 1.25%</td> </tr> <tr> <td>110 – 1.5%</td> <td>110 ± 1.5%</td> </tr> <tr> <td>111 – 2.0%</td> <td>111 ± 2.0%</td> </tr> </table>	<b>Down</b>	<b>Center</b>	000 (off)	000 (off)	001 – 0.25%	001 ± 0.25%	010 – 0.5%	010 ± 0.5%	011 – 0.75%	011 ± 0.75%	100 – 1.0%	100 ± 1.0%	101 – 1.25%	101 ± 1.25%	110 – 1.5%	110 ± 1.5%	111 – 2.0%	111 ± 2.0%
	<b>Down</b>	<b>Center</b>																				
	000 (off)	000 (off)																				
001 – 0.25%	001 ± 0.25%																					
010 – 0.5%	010 ± 0.5%																					
011 – 0.75%	011 ± 0.75%																					
100 – 1.0%	100 ± 1.0%																					
101 – 1.25%	101 ± 1.25%																					
110 – 1.5%	110 ± 1.5%																					
111 – 2.0%	111 ± 2.0%																					
4:2	SSC2_6 [2:0]	000b																				
1:0	SSC2_5 [2:1]	000b																				
7	SSC2_5 [0]																					
21h	6:4	SSC2_4 [2:0]	000b																			
	3:1	SSC2_3 [2:0]	000b																			
	0	SSC2_2 [2]	000b																			
22h	7:6	SSC2_2 [1:0]																				
	5:3	SSC2_1 [2:0]	000b																			
	2:0	SSC2_0 [2:0]	000b																			
23h	7	FS2_7	0b	FS2_x: PLL2 Frequency Selection <sup>(4)</sup>  0 – f <sub>VCO2_0</sub> (predefined by PLL2_0 – Multiplier/Divider value) 1 – f <sub>VCO2_1</sub> (predefined by PLL2_1 – Multiplier/Divider value)																		
	6	FS2_6	0b																			
	5	FS2_5	0b																			
	4	FS2_4	0b																			
	3	FS2_3	0b																			
	2	FS2_2	0b																			
	1	FS2_1	0b																			
	0	FS2_0	0b																			
24h	7	MUX2	1b	PLL2 Multiplexer: 0 – PLL2 1 – PLL2 Bypass (PLL2 is in power down)																		
	6	M4	1b	Output Y4 Multiplexer: 0 – Pdiv2 1 – Pdiv4																		
	5:4	M5	10b	Output Y5 Multiplexer: 00 – Pdiv2-Divider 01 – Pdiv4-Divider 10 – Pdiv5-Divider 11 – reserved																		
	3:2	Y4Y5_ST1	11b	Y4, Y5-State0/1definition: 00 – Y4/Y5 disabled to 3-State (PLL2 is in power down) 01 – Y4/Y5 disabled to 3-State (PLL2 on) 10–Y4/Y5 disabled to low (PLL2 on) 11 – Y4/Y5 enabled (normal operation, PLL2 on)																		
	1:0	Y4Y5_ST0	01b																			
25h	7	Y4Y5_7	0b	Y4Y5_x Output State Selection <sup>(4)</sup>  0 – state0 (predefined by Y4Y5_ST0) 1 – state1 (predefined by Y4Y5_ST1)																		
	6	Y4Y5_6	0b																			
	5	Y4Y5_5	0b																			
	4	Y4Y5_4	0b																			
	3	Y4Y5_3	0b																			
	2	Y4Y5_2	0b																			
	1	Y4Y5_1	1b																			
	0	Y4Y5_0	0b																			
26h	7	SSC2DC	0b	PLL2 SSC down/center selection: 0 – down 1 – center																		
	6:0	Pdiv4	01h	7-Bit Y4-Output-Divider Pdiv4: 0 – reset and stand-by 1-to-127 – divider value																		
27h	7	—	0b	Reserved – do not write others than 0																		
	6:0	Pdiv5	01h	7-Bit Y5-Output-Divider Pdiv5: 0 – reset and stand-by 1-to-127 – divider value																		

(1) Writing data beyond 50h may adversely affect device function.

(2) All data is transferred MSB-first.

(3) Unless a custom setting is used

(4) The user can pre-define up to eight different control settings. In normal device operation, these settings can be selected by the external control pins, S0, S1, and S2.

**Table 11. PLL2 Configuration Register (continued)**

OFFSET <sup>(1)</sup>	Bit <sup>(2)</sup>	Acronym	Default <sup>(3)</sup>	DESCRIPTION	
28h	7:0	PLL2_0N [11:4]	004h	PLL2_0: 30-Bit Multiplier/Divider value for frequency $f_{VCO2\_0}$ (for more information see paragraph <i>PLL Multiplier/Divider Definition</i> )	
29h	7:4	PLL2_0N [3:0]			
2Ah	3:0	PLL2_0R [8:5]	000h		
	7:3	PLL2_0R[4:0]			
2Bh	2:0	PLL2_0Q [5:3]	10h		
	7:5	PLL2_0Q [2:0]			
	4:2	PLL2_0P [2:0]			010b
	1:0	VCO2_0_RANGE	00b		$f_{VCO2\_0}$ range selection: 00 – $f_{VCO2\_0} < 125$ MHz 01 – $125 \text{ MHz} \leq f_{VCO2\_0} < 150$ MHz 10 – $150 \text{ MHz} \leq f_{VCO2\_0} < 175$ MHz 11 – $f_{VCO2\_0} \geq 175$ MHz
2Ch	7:0	PLL2_1N [11:4]	004h		PLL2_1: 30-Bit Multiplier/Divider value for frequency $f_{VCO1\_1}$ (for more information see paragraph <i>PLL Multiplier/Divider Definition</i> )
2Dh	7:4	PLL2_1N [3:0]			
2Eh	3:0	PLL2_1R [8:5]	000h		
	7:3	PLL2_1R[4:0]			
2Fh	2:0	PLL2_1Q [5:3]	10h		
	7:5	PLL2_1Q [2:0]			
	4:2	PLL2_1P [2:0]		010b	
	1:0	VCO2_1_RANGE	00b	$f_{VCO2\_1}$ range selection: 00 – $f_{VCO2\_1} < 125$ MHz 01 – $125 \text{ MHz} \leq f_{VCO2\_1} < 150$ MHz 10 – $150 \text{ MHz} \leq f_{VCO2\_1} < 175$ MHz 11 – $f_{VCO2\_1} \geq 175$ MHz	

Table 12. PLL3 Configuration Register

OFFSET <sup>(1)</sup>	Bit <sup>(2)</sup>	Acronym	Default <sup>(3)</sup>	DESCRIPTION	
30h	7:5	SSC3_7 [2:0]	000b	SSC3: PLL3 SSC Selection (Modulation Amount) <sup>(4)</sup>  <b>Down</b> 000 (off) 001 – 0.25% 010 – 0.5% 011 – 0.75% 100 – 1.0% 101 – 1.25% 110 – 1.5% 111 – 2.0%  <b>Center</b> 000 (off) 001 ± 0.25% 010 ± 0.5% 011 ± 0.75% 100 ± 1.0% 101 ± 1.25% 110 ± 1.5% 111 ± 2.0%	
	4:2	SSC3_6 [2:0]	000b		
	1:0	SSC3_5 [2:1]	000b		
31h	7	SSC3_5 [0]	000b		
	6:4	SSC3_4 [2:0]	000b		
	3:1	SSC3_3 [2:0]	000b		
32h	0	SSC3_2 [2]	000b		
	7:6	SSC3_2 [1:0]	000b		
	5:3	SSC3_1 [2:0]	000b		
33h	2:0	SSC3_0 [2:0]	000b		
	7	FS3_7	0b		FS3_x: PLL3 Frequency Selection <sup>(4)</sup>  0 – f <sub>VCO3_0</sub> (predefined by PLL3_0 – Multiplier/Divider value) 1 – f <sub>VCO3_1</sub> (predefined by PLL3_1 – Multiplier/Divider value)
	6	FS3_6	0b		
	5	FS3_5	0b		
	4	FS3_4	0b		
	3	FS3_3	0b		
	2	FS3_2	0b		
	1	FS3_1	0b		
0	FS3_0	0b			
34h	7	MUX3	1b	PLL3 Multiplexer: 0 – PLL3 1 – PLL3 Bypass (PLL3 is in power down)	
	6	M6	1b	Output Y6 Multiplexer: 0 – Pdiv4 1 – Pdiv6	
	5:4	M7	10b	Output Y7 Multiplexer: 00 – Pdiv4-Divider 01 – Pdiv6-Divider 10 – Pdiv7-Divider 11 – reserved	
	3:2	Y6Y7_ST1	11b	Y6, Y7-State0/1definition: 00 – Y6/Y7 disabled to 3-State (PLL3 is in power down) 01 – Y6/Y7 disabled to 3-State (PLL3 on) 10 – Y6/Y7 disabled to low (PLL3 on) 11 – Y6/Y7 enabled (normal operation, PLL3 on)	
	1:0	Y6Y7_ST0	01b		
35h	7	Y6Y7_7	0b	Y6Y7_x Output State Selection <sup>(4)</sup>  0 – state0 (predefined by Y6Y7_ST0) 1 – state1 (predefined by Y6Y7_ST1)	
	6	Y6Y7_6	0b		
	5	Y6Y7_5	0b		
	4	Y6Y7_4	0b		
	3	Y6Y7_3	0b		
	2	Y6Y7_2	0b		
	1	Y6Y7_1	1b		
	0	Y6Y7_0	0b		
36h	7	SSC3DC	0b	PLL3 SSC down/center selection: 0 – down 1 – center	
	6:0	Pdiv6	01h	7-Bit Y6-Output-Divider Pdiv6: 0 – reset and stand-by 1-to-127 – divider value	
37h	7	—	0b	Reserved – do not write others than 0	
	6:0	Pdiv7	01h	7-Bit Y7-Output-Divider Pdiv7: 0 – reset and stand-by 1-to-127 – divider value	

(1) Writing data beyond 50h may adversely affect device function.

(2) All data is transferred MSB-first.

(3) Unless a custom setting is used

(4) The user can pre-define up to eight different control settings. In normal device operation, these settings can be selected by the external control pins, S0, S1, and S2.

**Table 12. PLL3 Configuration Register (continued)**

OFFSET <sup>(1)</sup>	Bit <sup>(2)</sup>	Acronym	Default <sup>(3)</sup>	DESCRIPTION
38h	7:0	PLL3_0N [11:4]	004h	PLL3_0: 30-Bit Multiplier/Divider value for frequency $f_{VCO3\_0}$ (for more information see paragraph <i>PLL Multiplier/Divider Definition</i> )
39h	7:4	PLL3_0N [3:0]		
3Ah	3:0	PLL3_0R [8:5]	000h	
	7:3	PLL3_0R[4:0]	10h	
3Bh	2:0	PLL3_0Q [5:3]		
	7:5	PLL3_0Q [2:0]		
	4:2	PLL3_0P [2:0]		
	1:0	VCO3_0_RANGE	00b	$f_{VCO3\_0}$ range selection: 00 – $f_{VCO3\_0} < 125$ MHz 01 – $125 \text{ MHz} \leq f_{VCO3\_0} < 150$ MHz 10 – $150 \text{ MHz} \leq f_{VCO3\_0} < 175$ MHz 11 – $f_{VCO3\_0} \geq 175$ MHz
3Ch	7:0	PLL3_1N [11:4]	004h	PLL3_1: 30-Bit Multiplier/Divider value for frequency $f_{VCO3\_1}$ (for more information see paragraph <i>PLL Multiplier/Divider Definition</i> )
3Dh	7:4	PLL3_1N [3:0]		
3Eh	3:0	PLL3_1R [8:5]	000h	
	7:3	PLL3_1R[4:0]	10h	
3Fh	2:0	PLL3_1Q [5:3]		
	7:5	PLL3_1Q [2:0]		
	4:2	PLL3_1P [2:0]		
	1:0	VCO3_1_RANGE	00b	$f_{VCO3\_1}$ range selection: 00 – $f_{VCO3\_1} < 125$ MHz 01 – $125 \text{ MHz} \leq f_{VCO3\_1} < 150$ MHz 10 – $150 \text{ MHz} \leq f_{VCO3\_1} < 175$ MHz 11 – $f_{VCO3\_1} \geq 175$ MHz

Table 13. PLL4 Configuration Register

OFFSET <sup>(1)</sup>	Bit <sup>(2)</sup>	Acronym	Default <sup>(3)</sup>	DESCRIPTION																		
40h	7:5	SSC4_7 [2:0]	000b	SSC4: PLL4 SSC Selection (Modulation Amount) <sup>(4)</sup>  <table style="width: 100%; border: none;"> <tr> <td style="width: 50%;"><b>Down</b></td> <td style="width: 50%;"><b>Center</b></td> </tr> <tr> <td>000 (off)</td> <td>000 (off)</td> </tr> <tr> <td>001 – 0.25%</td> <td>001 ± 0.25%</td> </tr> <tr> <td>010 – 0.5%</td> <td>010 ± 0.5%</td> </tr> <tr> <td>011 – 0.75%</td> <td>011 ± 0.75%</td> </tr> <tr> <td>100 – 1.0%</td> <td>100 ± 1.0%</td> </tr> <tr> <td>101 – 1.25%</td> <td>101 ± 1.25%</td> </tr> <tr> <td>110 – 1.5%</td> <td>110 ± 1.5%</td> </tr> <tr> <td>111 – 2.0%</td> <td>111 ± 2.0%</td> </tr> </table>	<b>Down</b>	<b>Center</b>	000 (off)	000 (off)	001 – 0.25%	001 ± 0.25%	010 – 0.5%	010 ± 0.5%	011 – 0.75%	011 ± 0.75%	100 – 1.0%	100 ± 1.0%	101 – 1.25%	101 ± 1.25%	110 – 1.5%	110 ± 1.5%	111 – 2.0%	111 ± 2.0%
	<b>Down</b>	<b>Center</b>																				
	000 (off)	000 (off)																				
001 – 0.25%	001 ± 0.25%																					
010 – 0.5%	010 ± 0.5%																					
011 – 0.75%	011 ± 0.75%																					
100 – 1.0%	100 ± 1.0%																					
101 – 1.25%	101 ± 1.25%																					
110 – 1.5%	110 ± 1.5%																					
111 – 2.0%	111 ± 2.0%																					
4:2	SSC4_6 [2:0]	000b																				
1:0	SSC4_5 [2:1]	000b																				
41h	7		SSC4_5 [0]																			
	6:4	SSC4_4 [2:0]	000b																			
	3:1	SSC4_3 [2:0]	000b																			
42h	0	SSC4_2 [2]	000b																			
	7:6	SSC4_2 [1:0]																				
	5:3	SSC4_1 [2:0]		000b																		
	2:0	SSC4_0 [2:0]	000b																			
43h	7	FS4_7	0b	FS4_x: PLL4 Frequency Selection <sup>(4)</sup>  0 – $f_{VCO4\_0}$ (predefined by PLL4_0 – Multiplier/Divider value) 1 – $f_{VCO4\_1}$ (predefined by PLL4_1 – Multiplier/Divider value)																		
	6	FS4_6	0b																			
	5	FS4_5	0b																			
	4	FS4_4	0b																			
	3	FS4_3	0b																			
	2	FS4_2	0b																			
	1	FS4_1	0b																			
	0	FS4_0	0b																			
44h	7	MUX4	1b	PLL4 Multiplexer: 0 – PLL4 1 – PLL4 Bypass (PLL4 is in power down)																		
	6	M8	1b	Output Y8 Multiplexer: 0 – Pdiv6 1 – Pdiv8																		
	5:4	M9	10b	Output Y9 Multiplexer: 00 – Pdiv6-Divider 01 – Pdiv8-Divider 10 – Pdiv9-Divider 11 – reserved																		
	3:2	Y8Y9_ST1	11b	Y8, Y9-State0/1definition: 00 – Y8/Y9 disabled to 3-State (PLL4 is in power down) 01 – Y8/Y9 disabled to 3-State (PLL4 on) 10 – Y8/Y9 disabled to low (PLL4 on) 11 – Y8/Y9 enabled (normal operation, PLL4 on)																		
	1:0	Y8Y9_ST0	01b																			
45h	7	Y8Y9_7	0b	Y8Y9_x Output State Selection <sup>(4)</sup>  0 – state0 (predefined by Y8Y9_ST0) 1 – state1 (predefined by Y8Y9_ST1)																		
	6	Y8Y9_6	0b																			
	5	Y8Y9_5	0b																			
	4	Y8Y9_4	0b																			
	3	Y8Y9_3	0b																			
	2	Y8Y9_2	0b																			
	1	Y8Y9_1	1b																			
	0	Y8Y9_0	0b																			
46h	7	SSC4DC	0b	PLL4 SSC down/center selection: 0 – down 1 – center																		
	6:0	Pdiv8	01h	7-Bit Y8-Output-Divider Pdiv8: 0 – reset and stand-by 1-to-127 – divider value																		
47h	7	—	0b	Reserved – do not write others than 0																		
	6:0	Pdiv9	01h	7-Bit Y9-Output-Divider Pdiv9: 0 – reset and stand-by 1-to-127 – divider value																		

(1) Writing data beyond 50h may adversely affect device function.

(2) All data is transferred MSB-first.

(3) Unless a custom setting is used

(4) The user can pre-define up to eight different control settings. In normal device operation, these settings can be selected by the external control pins, S0, S1, and S2.

**Table 13. PLL4 Configuration Register (continued)**

OFFSET <sup>(1)</sup>	Bit <sup>(2)</sup>	Acronym	Default <sup>(3)</sup>	DESCRIPTION	
48h	7:0	PLL4_0N [11:4]	004h	PLL4_0: 30-Bit Multiplier/Divider value for frequency $f_{VCO4\_0}$ (for more information see paragraph <i>PLL Multiplier/Divider Definition</i> )	
49h	7:4	PLL4_0N [3:0]			
4Ah	3:0	PLL4_0R [8:5]	000h		
	7:3	PLL4_0R[4:0]	10h		
4Bh	2:0	PLL4_0Q [5:3]			010b
	7:5	PLL4_0Q [2:0]			
	4:2	PLL4_0P [2:0]			
	1:0	VCO4_0_RANGE	00b		$f_{VCO4\_0}$ range selection: 00 – $f_{VCO4\_0} < 125$ MHz 01 – $125 \text{ MHz} \leq f_{VCO4\_0} < 150$ MHz 10 – $150 \text{ MHz} \leq f_{VCO4\_0} < 175$ MHz 11 – $f_{VCO4\_0} \geq 175$ MHz
4Ch	7:0	PLL4_1N [11:4]	004h		PLL4_1: 30-Bit Multiplier/Divider value for frequency $f_{VCO4\_1}$ (for more information see paragraph <i>PLL Multiplier/Divider Definition</i> )
4Dh	7:4	PLL4_1N [3:0]			
4Eh	3:0	PLL4_1R [8:5]	000h		
	7:3	PLL4_1R[4:0]	10h		
4Fh	2:0	PLL4_1Q [5:3]		010b	
	7:5	PLL4_1Q [2:0]			
	4:2	PLL4_1P [2:0]			
	1:0	VCO4_1_RANGE	00b	$f_{VCO4\_1}$ range selection: 00 – $f_{VCO4\_1} < 125$ MHz 01 – $125 \text{ MHz} \leq f_{VCO4\_1} < 150$ MHz 10 – $150 \text{ MHz} \leq f_{VCO4\_1} < 175$ MHz 11 – $f_{VCO4\_1} \geq 175$ MHz	

## PLL MULTIPLIER/DIVIDER DEFINITION

At a given input frequency ( $f_{IN}$ ), the output frequency ( $f_{OUT}$ ) of the CDCE949/CDCEL949 can be calculated by:

$$f_{OUT} = \frac{f_{IN}}{P_{div}} \times \frac{N}{M}$$

where

M (1 to 511) and N (1 to 4095) are the multiplier/divider values of the PLL;  
Pdiv (1 to 127) is the output divider.

The target VCO frequency ( $f_{VCO}$ ) of each PLL can be calculated:

$$f_{VCO} = f_{IN} \times \frac{N}{M}$$

The PLL operates as fractional divider and needs following multiplier/divider settings

$$N$$

$$P = 4 - \text{int}(\log_2 \frac{N}{M}) \quad \{\text{if } P < 0 \text{ then } P = 0\}$$

$$Q = \text{int}(\frac{N'}{M})$$

$$R = N' - M \times Q$$

Where:

$$N' = N \times 2^P;$$

$$N \geq M;$$

$$80 \text{ MHz} < f_{VCO} < 230 \text{ MHz}.$$

**Example 1:** for  $f_{IN} = 27 \text{ MHz}$ ;  $M = 1$ ;  $N = 4$ ;  $P_{div} = 2$ ;

$$\rightarrow f_{OUT} = 54 \text{ MHz};$$

$$\rightarrow f_{VCO} = 108 \text{ MHz};$$

$$\rightarrow P = 4 - \text{int}(\log_2 4) = 4 - 2 = 2;$$

$$\rightarrow N' = 4 \times 2^2 = 16;$$

$$\rightarrow Q = \text{int}(16) = 16;$$

$$\rightarrow R = 16 - 16 = 0;$$

**Example 2:** for  $f_{IN} = 27 \text{ MHz}$ ;  $M = 2$ ;  $N = 11$ ;  $P_{div} = 2$ ;

$$\rightarrow f_{OUT} = 75.25 \text{ MHz};$$

$$\rightarrow f_{VCO} = 148.50 \text{ MHz};$$

$$\rightarrow P = 4 - \text{int}(\log_2 5.5) = 4 - 2 = 2;$$

$$\rightarrow N' = 11 \times 2^2 = 44;$$

$$\rightarrow Q = \text{int}(22) = 22;$$

$$\rightarrow R = 44 - 44 = 0;$$

The values for P, Q, R and N' are automatically calculated when using TI Pro Clock™ Software.

## HISTORY

Data sheet Revision	Modified by	Date	Modified Content
0.10	Georg Becke	18, May 2006	Created initial Specification;
0.11	Georg Becke	26, May 2006	Added updates according the Spec' Review Meeting held 5/19/2006;
0.20	Georg Becke	31, May 2006	Version for Plan-DPR;
0.21	Georg Becke	9, Jun 2006	Updated SDA/SCL 2-wire interface specification; block-diagrams, pin-assignments register configuration bitmap; control terminal pin descriptions;
0.22	Georg Becke	20, Jul 2006	Updated control register setting; change pull-up value of S0, S1, S2 to 500Kohm to be conform with I2C spec'; updated Register Configuration Bitmap; added default device configuration;
0.25	Georg Becke	24, Jul 2006	Created CDCE949 datasheet from CDCE9xx version 0.22;
0.26	Georg Becke	28, Jul 2006	Added SDA/SCL Configuration Register definition and bit assignment;
0.27	Georg Becke	15, Sep 2006	Added low/high-speed VCO mode to configuration register (2-bit = 4 options); added CDCEL949; modified Configuration Register; updated address bits and PLL dividers in conf reg.; added 50 Ohm termination load;
0.28	Georg Becke	25, Oct 2006	Add 1.8V outputs to head-line; updated IIL for S0/1/2 to -4uA; modified configuration registers and changed "acronym" to be more readable; re-arranged bits/bytes in generic configuration register; added PLL frequency calculation; described that EELock and SPICON is valid only if written into the EEPROM; changed block diagrams to show "EEPROM-Block";
0.29	Georg Becke	21, Nov 2006	Added 500K pull-up to SDA/SCL input; added div-by-0 (=reset) to post-dividers function; corrected calculation of "R" for 30-bit PLL divider; corrected default setting for Yn on page 12; change order of freq-select and SSC-select in the tables (ETC request) → no change in Control registers; add 1 bit for E vs EL identification; made some word adjustment to some text sections;
0.30	Georg Becke	8, Dec 2006	Added "not write beyond 50h" (note 1); added CL description (note 8); change note 9 – EEWRITE; modified Yx default setting; added Vdd pin 13 to Terminal Functions; added "not overwrite" to reserved bits; changed acronyms for Yx_STy;
0.31	Georg Becke	19, Dec 2006	Updated first three pages; forwarded version 0.31 to TIS;
0.32	Georg Becke	15. Feb 2007	General Update at feature block, terminal function, Vi, X-tal-Spec, SDA-Hold-time, Ctrl-terminal Register, bit-map description (generic, PLL1, PLL2, PLL3, PLL4), load cap drawing and relevant note, PLL frequency calculation
0.33	Georg Becke	11. Apr 2007	Added "Block Read" comment; changed slave adr bits;
0.4	Georg Becke	11. May 2007	Char&ATE Review

**PACKAGING INFORMATION**

Orderable Device	Status <sup>(1)</sup>	Package Type	Package Drawing	Pins	Package Qty	Eco Plan <sup>(2)</sup>	Lead/Ball Finish	MSL Peak Temp <sup>(3)</sup>
CDCE949PW	ACTIVE	TSSOP	PW	24	60	Green (RoHS & no Sb/Br)	CU NIPDAU	Level-1-260C-UNLIM
CDCE949PWG4	ACTIVE	TSSOP	PW	24	60	Green (RoHS & no Sb/Br)	CU NIPDAU	Level-1-260C-UNLIM
CDCE949PWR	ACTIVE	TSSOP	PW	24	2000	Green (RoHS & no Sb/Br)	CU NIPDAU	Level-1-260C-UNLIM
CDCE949PWRG4	ACTIVE	TSSOP	PW	24	2000	Green (RoHS & no Sb/Br)	CU NIPDAU	Level-1-260C-UNLIM

<sup>(1)</sup> The marketing status values are defined as follows:

**ACTIVE:** Product device recommended for new designs.

**LIFEBUY:** TI has announced that the device will be discontinued, and a lifetime-buy period is in effect.

**NRND:** Not recommended for new designs. Device is in production to support existing customers, but TI does not recommend using this part in a new design.

**PREVIEW:** Device has been announced but is not in production. Samples may or may not be available.

**OBSOLETE:** TI has discontinued the production of the device.

<sup>(2)</sup> Eco Plan - The planned eco-friendly classification: Pb-Free (RoHS), Pb-Free (RoHS Exempt), or Green (RoHS & no Sb/Br) - please check <http://www.ti.com/productcontent> for the latest availability information and additional product content details.

**TBD:** The Pb-Free/Green conversion plan has not been defined.

**Pb-Free (RoHS):** TI's terms "Lead-Free" or "Pb-Free" mean semiconductor products that are compatible with the current RoHS requirements for all 6 substances, including the requirement that lead not exceed 0.1% by weight in homogeneous materials. Where designed to be soldered at high temperatures, TI Pb-Free products are suitable for use in specified lead-free processes.

**Pb-Free (RoHS Exempt):** This component has a RoHS exemption for either 1) lead-based flip-chip solder bumps used between the die and package, or 2) lead-based die adhesive used between the die and leadframe. The component is otherwise considered Pb-Free (RoHS compatible) as defined above.

**Green (RoHS & no Sb/Br):** TI defines "Green" to mean Pb-Free (RoHS compatible), and free of Bromine (Br) and Antimony (Sb) based flame retardants (Br or Sb do not exceed 0.1% by weight in homogeneous material)

<sup>(3)</sup> MSL, Peak Temp. -- The Moisture Sensitivity Level rating according to the JEDEC industry standard classifications, and peak solder temperature.

**Important Information and Disclaimer:**The information provided on this page represents TI's knowledge and belief as of the date that it is provided. TI bases its knowledge and belief on information provided by third parties, and makes no representation or warranty as to the accuracy of such information. Efforts are underway to better integrate information from third parties. TI has taken and continues to take reasonable steps to provide representative and accurate information but may not have conducted destructive testing or chemical analysis on incoming materials and chemicals. TI and TI suppliers consider certain information to be proprietary, and thus CAS numbers and other limited information may not be available for release.

In no event shall TI's liability arising out of such information exceed the total purchase price of the TI part(s) at issue in this document sold by TI to Customer on an annual basis.

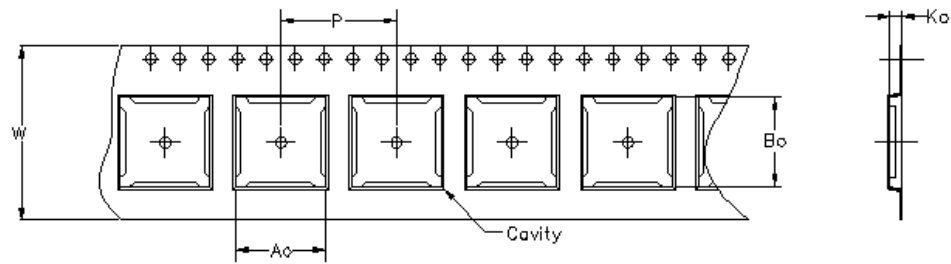

Carrier tape design is defined largely by the component length, width, and thickness.

$A_o$ = Dimension designed to accommodate the component width.
$B_o$ = Dimension designed to accommodate the component length.
$K_o$ = Dimension designed to accommodate the component thickness.
$W$ = Overall width of the carrier tape.
$P$ = Pitch between successive cavity centers.

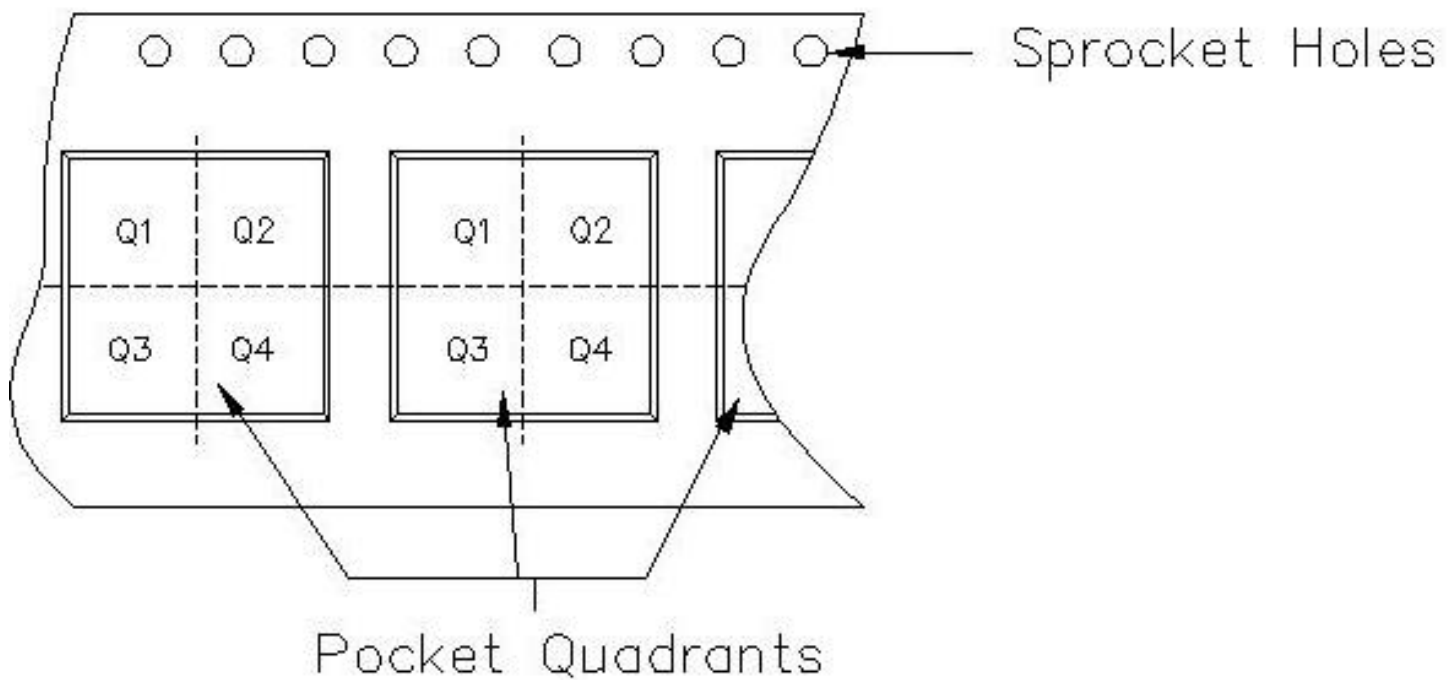

**TAPE AND REEL INFORMATION**

Device	Package	Pins	Site	Reel Diameter (mm)	Reel Width (mm)	A0 (mm)	B0 (mm)	K0 (mm)	P1 (mm)	W (mm)	Pin1 Quadrant
CDCE949PWR	PW	24	MLA	330	16	6.95	8.3	1.6	8	16	Q1

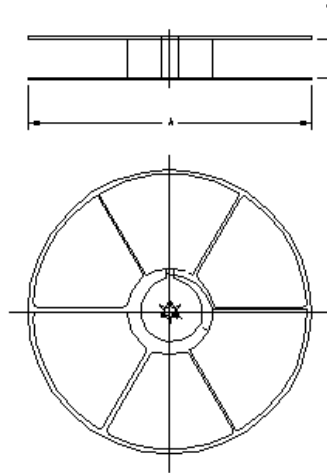

**TAPE AND REEL BOX INFORMATION**

Device	Package	Pins	Site	Length (mm)	Width (mm)	Height (mm)
CDCE949PWR	PW	24	MLA	346.0	346.0	33.0

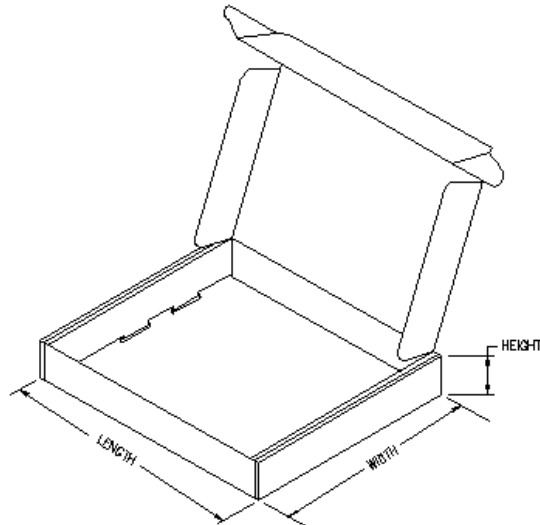

PW (R-PDSO-G\*\*)

PLASTIC SMALL-OUTLINE PACKAGE

14 PINS SHOWN

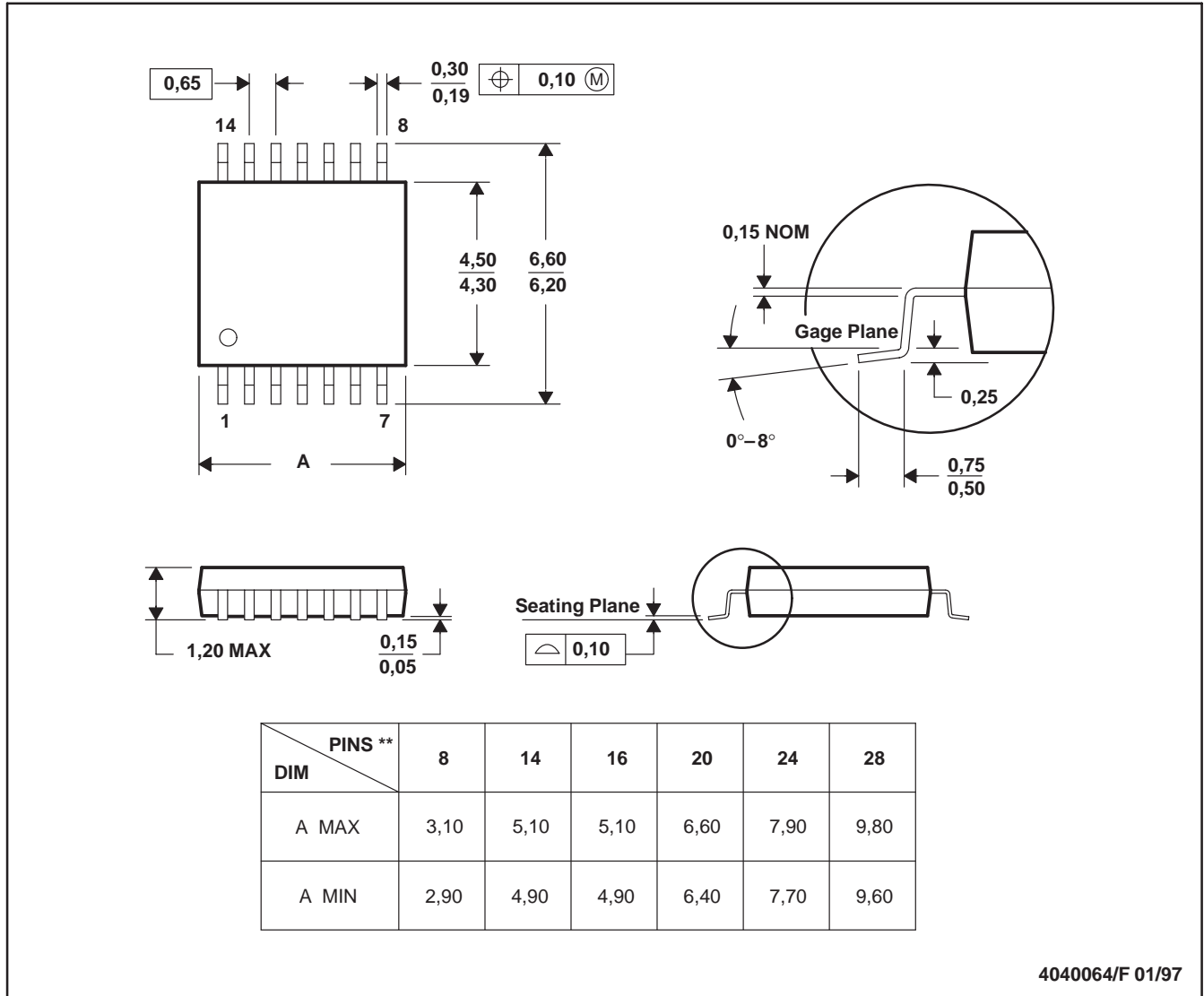

4040064/F 01/97

- NOTES: A. All linear dimensions are in millimeters.  
 B. This drawing is subject to change without notice.  
 C. Body dimensions do not include mold flash or protrusion not to exceed 0,15.  
 D. Falls within JEDEC MO-153

## IMPORTANT NOTICE

Texas Instruments Incorporated and its subsidiaries (TI) reserve the right to make corrections, modifications, enhancements, improvements, and other changes to its products and services at any time and to discontinue any product or service without notice. Customers should obtain the latest relevant information before placing orders and should verify that such information is current and complete. All products are sold subject to TI's terms and conditions of sale supplied at the time of order acknowledgment.

TI warrants performance of its hardware products to the specifications applicable at the time of sale in accordance with TI's standard warranty. Testing and other quality control techniques are used to the extent TI deems necessary to support this warranty. Except where mandated by government requirements, testing of all parameters of each product is not necessarily performed.

TI assumes no liability for applications assistance or customer product design. Customers are responsible for their products and applications using TI components. To minimize the risks associated with customer products and applications, customers should provide adequate design and operating safeguards.

TI does not warrant or represent that any license, either express or implied, is granted under any TI patent right, copyright, mask work right, or other TI intellectual property right relating to any combination, machine, or process in which TI products or services are used. Information published by TI regarding third-party products or services does not constitute a license from TI to use such products or services or a warranty or endorsement thereof. Use of such information may require a license from a third party under the patents or other intellectual property of the third party, or a license from TI under the patents or other intellectual property of TI.

Reproduction of TI information in TI data books or data sheets is permissible only if reproduction is without alteration and is accompanied by all associated warranties, conditions, limitations, and notices. Reproduction of this information with alteration is an unfair and deceptive business practice. TI is not responsible or liable for such altered documentation. Information of third parties may be subject to additional restrictions.

Resale of TI products or services with statements different from or beyond the parameters stated by TI for that product or service voids all express and any implied warranties for the associated TI product or service and is an unfair and deceptive business practice. TI is not responsible or liable for any such statements.

TI products are not authorized for use in safety-critical applications (such as life support) where a failure of the TI product would reasonably be expected to cause severe personal injury or death, unless officers of the parties have executed an agreement specifically governing such use. Buyers represent that they have all necessary expertise in the safety and regulatory ramifications of their applications, and acknowledge and agree that they are solely responsible for all legal, regulatory and safety-related requirements concerning their products and any use of TI products in such safety-critical applications, notwithstanding any applications-related information or support that may be provided by TI. Further, Buyers must fully indemnify TI and its representatives against any damages arising out of the use of TI products in such safety-critical applications.

TI products are neither designed nor intended for use in military/aerospace applications or environments unless the TI products are specifically designated by TI as military-grade or "enhanced plastic." Only products designated by TI as military-grade meet military specifications. Buyers acknowledge and agree that any such use of TI products which TI has not designated as military-grade is solely at the Buyer's risk, and that they are solely responsible for compliance with all legal and regulatory requirements in connection with such use.

TI products are neither designed nor intended for use in automotive applications or environments unless the specific TI products are designated by TI as compliant with ISO/TS 16949 requirements. Buyers acknowledge and agree that, if they use any non-designated products in automotive applications, TI will not be responsible for any failure to meet such requirements.

Following are URLs where you can obtain information on other Texas Instruments products and application solutions:

<b>Products</b>		<b>Applications</b>	
Amplifiers	<a href="http://amplifier.ti.com">amplifier.ti.com</a>	Audio	<a href="http://www.ti.com/audio">www.ti.com/audio</a>
Data Converters	<a href="http://dataconverter.ti.com">dataconverter.ti.com</a>	Automotive	<a href="http://www.ti.com/automotive">www.ti.com/automotive</a>
DSP	<a href="http://dsp.ti.com">dsp.ti.com</a>	Broadband	<a href="http://www.ti.com/broadband">www.ti.com/broadband</a>
Interface	<a href="http://interface.ti.com">interface.ti.com</a>	Digital Control	<a href="http://www.ti.com/digitalcontrol">www.ti.com/digitalcontrol</a>
Logic	<a href="http://logic.ti.com">logic.ti.com</a>	Military	<a href="http://www.ti.com/military">www.ti.com/military</a>
Power Mgmt	<a href="http://power.ti.com">power.ti.com</a>	Optical Networking	<a href="http://www.ti.com/opticalnetwork">www.ti.com/opticalnetwork</a>
Microcontrollers	<a href="http://microcontroller.ti.com">microcontroller.ti.com</a>	Security	<a href="http://www.ti.com/security">www.ti.com/security</a>
RFID	<a href="http://www.ti-rfid.com">www.ti-rfid.com</a>	Telephony	<a href="http://www.ti.com/telephony">www.ti.com/telephony</a>
Low Power Wireless	<a href="http://www.ti.com/lpw">www.ti.com/lpw</a>	Video & Imaging	<a href="http://www.ti.com/video">www.ti.com/video</a>
		Wireless	<a href="http://www.ti.com/wireless">www.ti.com/wireless</a>

Mailing Address: Texas Instruments, Post Office Box 655303, Dallas, Texas 75265  
Copyright © 2007, Texas Instruments Incorporated