

## Model 1440 High Power, N or SMK Connectors Convection Cooled

dc to 6.0 GHz  
100 Watts

**RoHS**

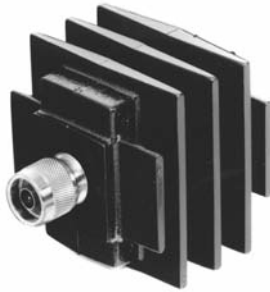

### MAXIMUM SWR:

Frequency (GHz)	SWR
dc - 6	1.15

**POWER RATING:** 100 watts **average** (mounted horizontally assuming unobstructed air flow and natural convection around unit) to 25°C ambient temperature, derated linearly to 10 watts @ 125°C. 10 kilowatts **peak** (5 µsec pulse width; 0.5 % duty cycle).

**TEMPERATURE RANGE:** -55°C to +125°C

**TEST DATA:** Swept data plots of SWR from 50 MHz to 6 GHz.

**CONNECTOR:** Type N connector per MIL-STD-348 interface dimensions - mate nondestructively with MIL-C-39012 connector. Choice of male (-4) or female connector (-3).

SMK (2.92mm) connector mates nondestructively with SMA per MIL-C-39012, 3.5mm and other 2.92mm (SMK) connector. Choice of male (-2) or female connector (-1).

**CONSTRUCTION:** Black, finned aluminum body, stainless steel connector; gold plated beryllium copper center contacts.

**WEIGHT:** 500 g (18 oz)

### Features

- /// **Compact Construction** - Lowest size/power ratio.
- /// **Low SWR**
- /// **Rugged Construction** - Quality connector with special high temperature support bead.
- /// **Ideal for Wireless Applications.**

### Specifications

**NOMINAL IMPEDANCE:** 50 Ω

**FREQUENCY RANGE:** dc to 6.0 GHz

### PHYSICAL DIMENSIONS:

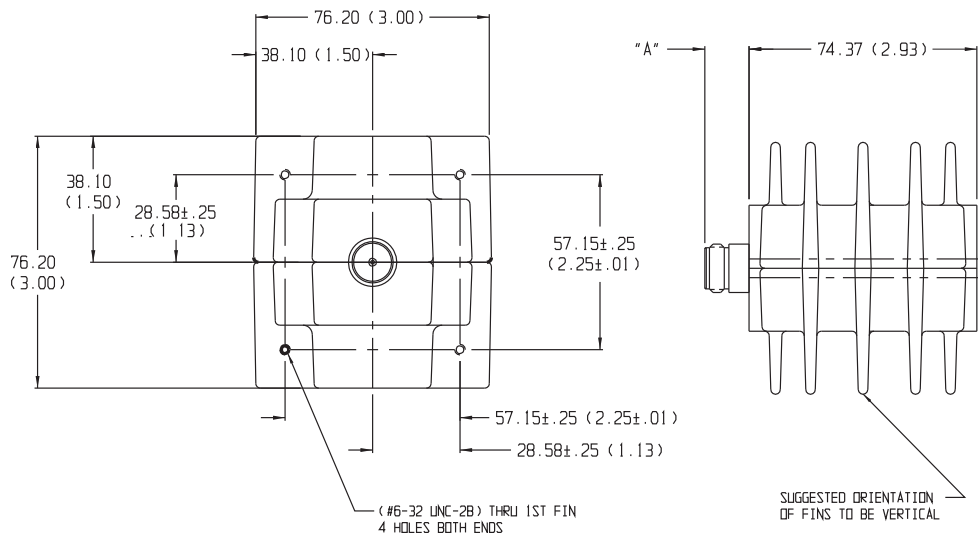

Model #	DIM A	Connector Type
1440-1	12.7 (0.50)	2.92mm female
1440-2	14.0 (0.55)	2.92mm male
1440-3	15.0 (0.59)	N female
1440-4	22.9 (0.90)	N male

**NOTE:** All dimensions are given in mm (inches) and are maximum, unless otherwise specified.