

SPECIFICATIONS

Rated Current: 3.0AMP
 Contact Resistance: 20mΩ Max
 Withstand Voltage: 1000V AC/DC
 Insulation Resistance: 1000MΩ Min
 Operation Temperature: -40°C to +105°C

Contact Material: Brass
 Contact Plating: Au Over Ni
 Insulator Material: Polyester (UL94V-0)
 Standard: PBT
 Max. Processing Temp: 180°C for 30-60 seconds
 (200°C for 10 seconds)

Recommended P.C.B Layout (Top Side)
 (PCB BOARD TOLERANCE ±0.05)

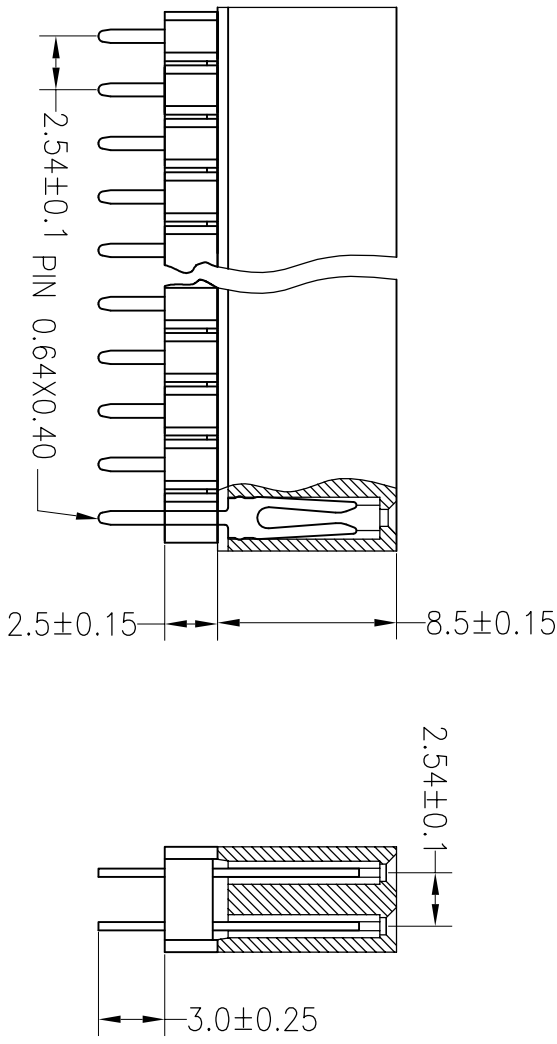
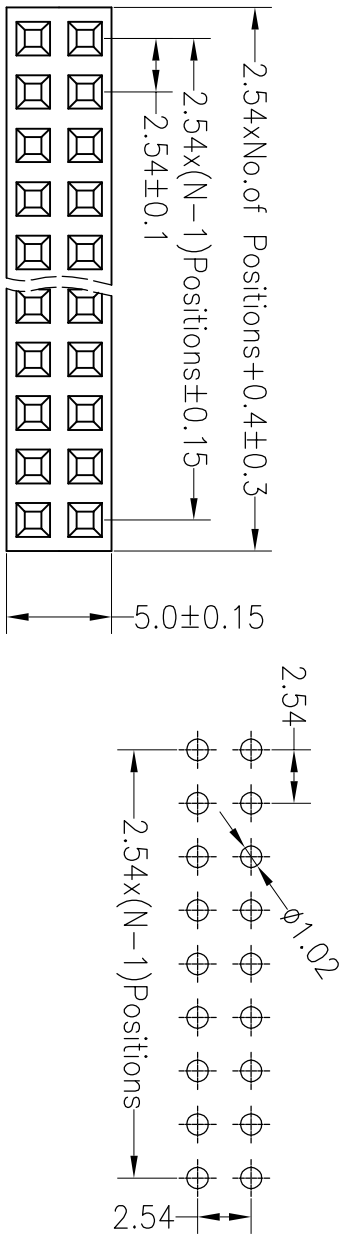

深圳市连盛精密连接器有限公司

REV	DATE	MODIFICATION DESCRIPTION	CHANGE	OPERATION		DRAW	SCALE		PART NO.	TITLE:
				X.X	±0.30		UNIT	FIT		
A0	2012.10.08	NEW DRAWING		X.XX	±0.20	CHECK	mm	A4	FH-00179---A0001	2.54FH H8.5mm+H2.5mm 2x30 pin DIP
				X.XXX	±0.10		SIZE			
				Angle	±3'	APPROVE	SHEET	1/1		
				DIM	TOL		PROJ.			