



LEDDC-25W Series– Fixed Output & Dimmable AC or DC Input Switch Mode LED Drivers Constant Current & Constant Voltage Output with Isolation Black Magic Thermal Advantage™ Plastic Housing

Electrical Specifications

Input Voltage Range:	100-277 Vac Nom. (90-305 V Min/Max), 108-250 Vdc
Frequency:	50/60 Hz Nom. (47-63 Hz Min/Max)
Power Factor:	>0.90 @ full load, 100V through 277V
Inrush Current:	<15.0 Amps @ 230 Vac, cold start 25°C, max load
Input Current:	0.25 Amps @ 120 Vac, 60 Hz, max load
Maximum Power:	25W
Current Accuracy:	± 2% Over input line variation
Load Regulation:	± 3%
THD:	≤ 20% @ full load
Leakage Current:	400 µA Typical
Hold Up Time:	Half Cycle
Protection:	Output Over-Voltage, Output Over-Current, and Output Short Circuit Protection reset by power cycling

Environmental Specifications

Minimum Starting Temp:	-30°C
Maximum Case Temp.	90°C
Storage Temperature:	-40°C to +85°C
Humidity:	5% to 95%
Cooling:	Convection
Vibration Frequency:	5 to 55 Hz/2g, 30 minutes
Impact Resistance:	1g/s
Sound Rating:	Class A
MTBF:	482,000 Hours at full load and 40°C ambient conditions per MIL-217F Notice 2
EMC:	FCC 47CFR Part 15 Class B compliant
Weight:	198g (7.0 oz)

Ordering Options:

- D: 0-10V & Resistance dimmable version comes with an extra two wires +Purple/-Gray on the output side. -D 0-10V Dimming is compatible with most quality 0-10V wall dimmers and direct 0-10V analog signal. See page 3 for additional specifications.
- PD: PWM Dimmable version comes with an extra two wires +Purple/-Gray on the output side. PD PWM version is PWM Dimmable via a positive 10% to 100% Duty Cycle, 200Hz to 1KHz, 0-10V Pulse. See page 4 for additional specifications.



- Total Power: 25 Watts
- Input Voltage: 100-277 Vac Nom. or 108-250 Vdc
- UL Dry & Damp Location Rated
- IP66 & NEMA4
- High Power Factor
- UL8750

Constant Current - Product Specifications

Model Number	Output Current (mA ±3%)	Output Voltage Range (Vdc)	Max. Output Power (W)	Typical Efficiency
LEDDC25W-072-C0350-XX	350	24-72	25	86%

-XX indicates dimming options are available. See options at left. Blank = fixed current output

Constant Voltage - Product Specifications

Model Number	Output Voltage (Vdc ±5%)	Output Current Range (mA)	Max. Output Power (W)	Typical Efficiency
LEDDC25W-072	72	88-350	25	86%



Note:
LED drivers are designed and intended to operate LED loads only. Non-LED loading may be outside the specified design limits of our LED drivers, and therefore cannot be covered by any warranty. If you desire to use our LED drivers to operate non-LED loads please contact us to discuss compatibility.

Specifications subject to change without notice.

Rev 9-2-15

Dimensions - Inches (mm)

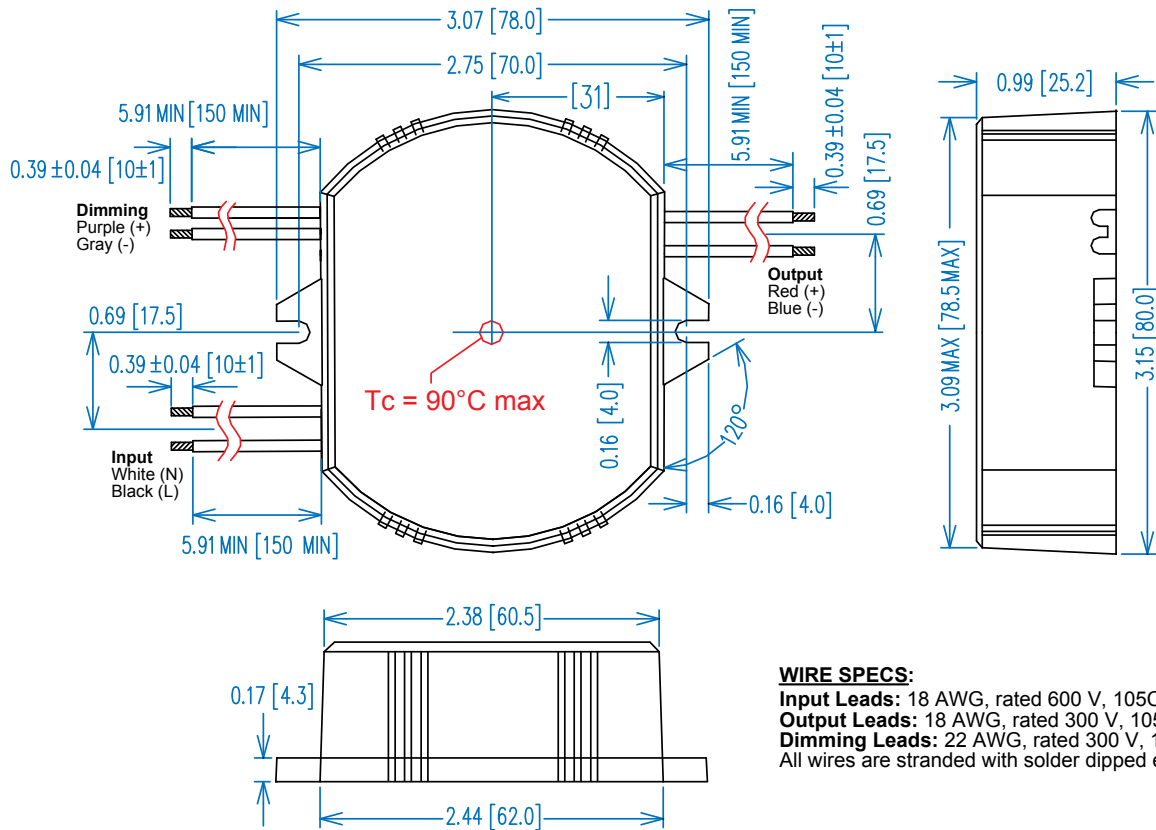

Safety and EMC Compliance	
UL/CUL	UL8750, CSA 22.2
C E	EN 61347
EN 61000-3-2	
EN 61000-3-3	Class C

UL Conditions of Acceptability

See website for additional information

“-D” Option: 0-10VDC and Resistance Dimming

Parameters	Minimum	Typical	Maximum
Source Current out of 0-10V Purple Wire	0mA	—	2 mA
Absolute Voltage Range on 0-10V (+) Purple Wire	-2.0V	—	+15V

Resistance Dimming Typical Circuit

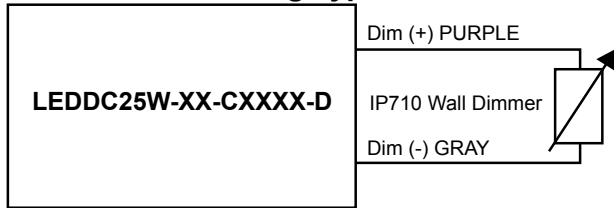

Output Current / 0-10VDC Dimming Input

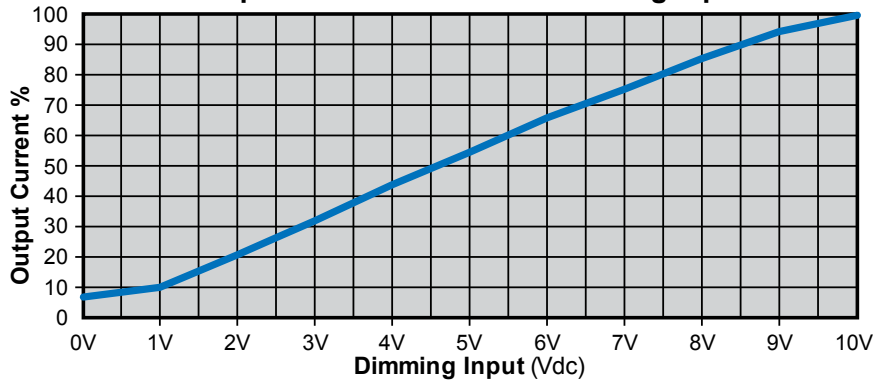

Notes:

1. 0-10V dimmable version comes with an extra two wires +Purple/-Gray on the output side.
2. Compatible with most 0-10V Wall Slide dimmers and direct 0-10V analog signal. Recommended dimmer is Leviton IP710 or equivalent
3. 0-10V dimmable version is not intended to dim below about 5% @ 0V or 10% @ 1.0V
4. 0-10V dimmable version output will be 100% with Purple/Gray open and minimum with Purple/Gray Shorted.

“-PD” Option: 0-10VDC and Resistance Dimming

Parameters	Minimum	Typical	Maximum
Absolute Maximum Voltage Range on PWM Input (Purple Wire)	-2.0V	10V	+28V
Input LOW Level Voltage Range (Purple Wire)	-2.0	0V	+7.5V
Input HIGH Level Voltage Range (Purple Wire)	+9.0	10V	28V
Sink Current into PWM Input (Purple Wire)	0mA	—	1.2mA
PWM Input Signal Frequency	200Hz	—	1000Hz
PWM Input Signal Positive Duty Cycle	0%	10-90%	100%

PWM Positive Dimming Typical Circuit

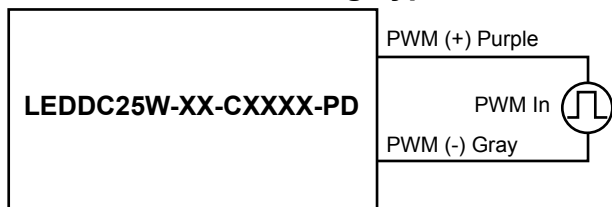

Output Current / Positive Duty Cycle

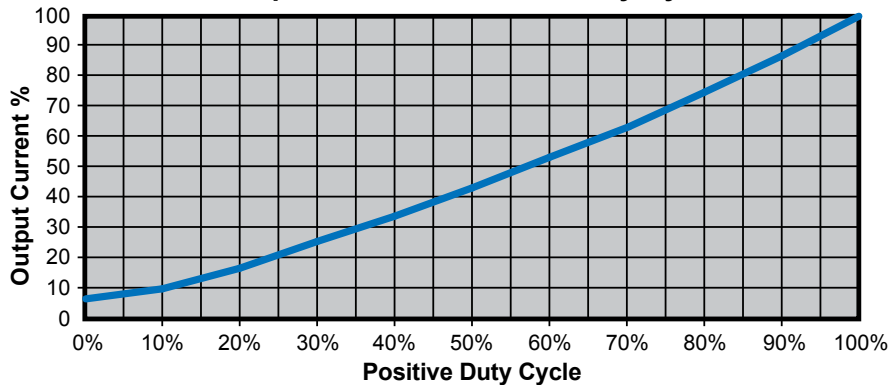

Notes:

1. PWM Dimmable version comes with an extra 2 wires +Purple/-Gray on the output side.
2. Below 10% Duty cycle proper dimming operation is not assured. Unit is not intended to turn off at <10% Duty Cycle.
3. PWM dimmable version output will be 100% with Purple/Gray open and minimum with Purple/Gray Shorted.

Note:

Disconnect power to LED driver for at least 30 seconds before connecting or disconnecting Driver output and LED Engine. This prevents potential arcing transients that can damage the Engine and Driver. See Hot Plugging in our Driver Application Guide for more information.