

HAOYU

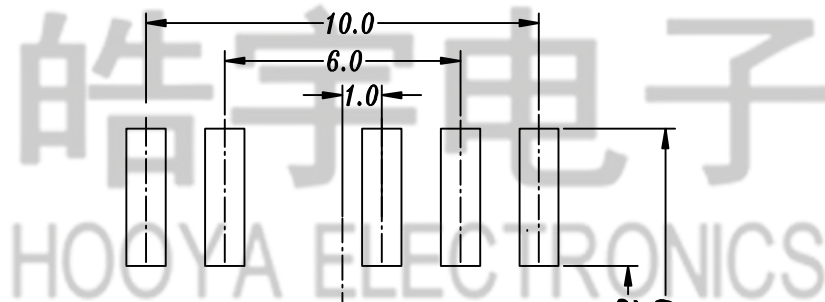
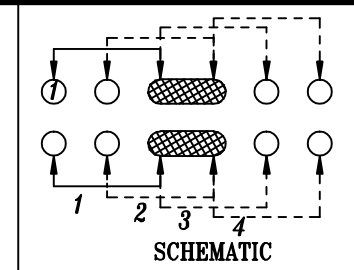
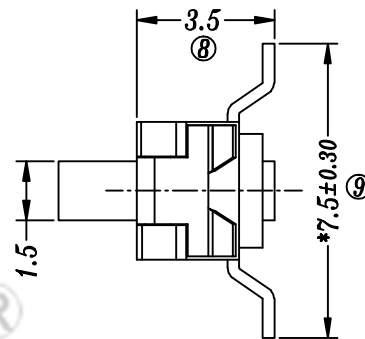
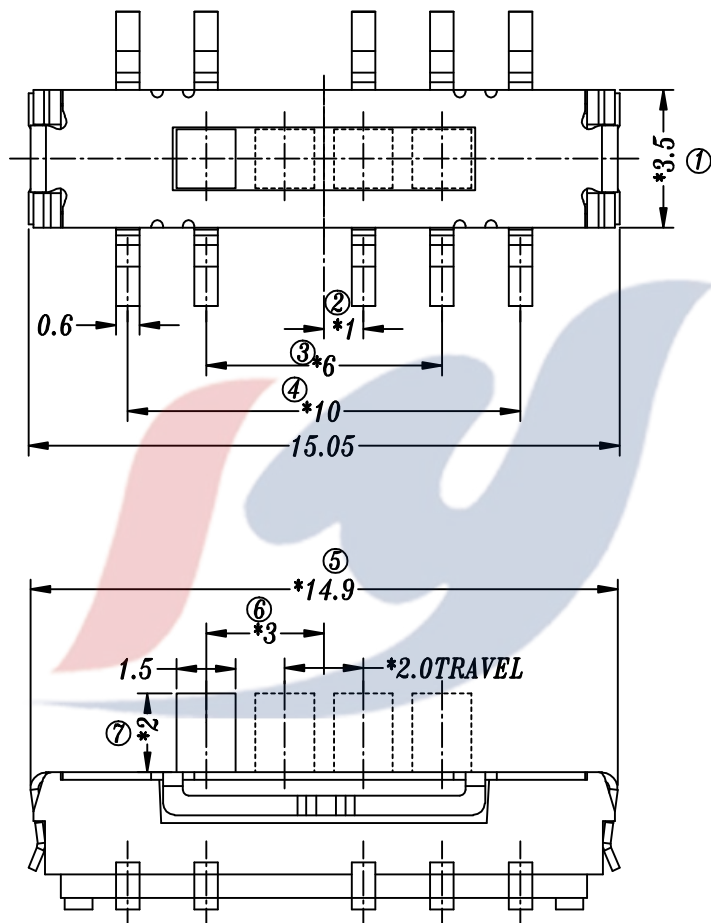

P.C.B LAYOUT

SPECIFICATION

1. Rating: DC 12V 0.3A
2. Travel: 2 mm
3. Function: 2P4T
4. Contact Resistance: $\leq 70m\Omega$ MAX
5. Operating Force: 200gf-350gf
6. Life test: 10,000 cycles

				TOLERANCE UNLESS SPECIFIED							
5	MK24D02 TERMINAL	BRASS	1	Ag PLATED	UP TO 5mm: ±0.1	ANGULAR	A0	2018.09.11	????	GYW	
4	MK23D38 SPRING	PBS $\phi 0.25$ mm	2	WASHING	ABOVE 5mm: ±0.2	±1°	NO	DATE	REVISIONS	BY	APPD
3	MK24D20 CASE	PA6T	1	BLACK	TITLE: MINI SLIDE SWITCH		UNIT : MM	ROHS COMPLIANT	DWN		
2	MS24D02 COVER	SUS	1	WASHING	MODEL: MS-24D20G2-B 弹线		SCALE: 5:1		CHK'D		
1	MS24D02 KNOB	PA46	1	BLACK	HAOYU(HONGKONG)LIMITED 皓宇(香港)有限公司				APPD		
NO.	PART NAME	MATERIAL	QTY	FINISHING			PRO.AGL:		REV :A0		