

DWC. NO.		353-060-0040H	
REV	DESCRIPTION	BY	APPD
A	NPR 1669	JED	2/7/00

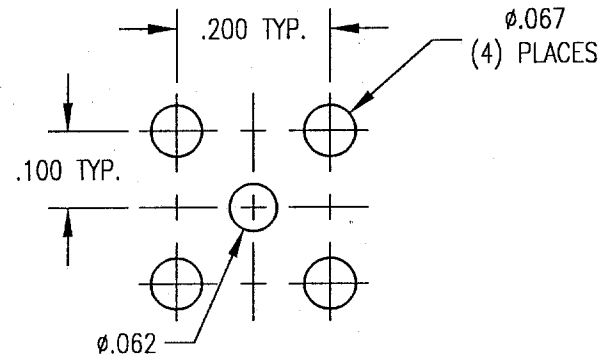
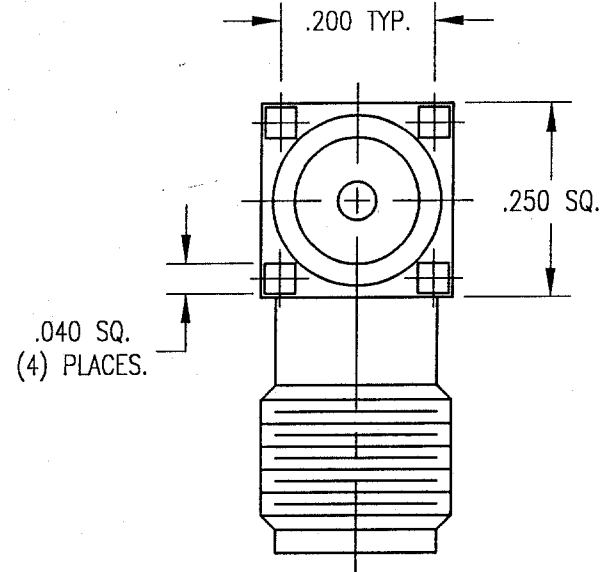
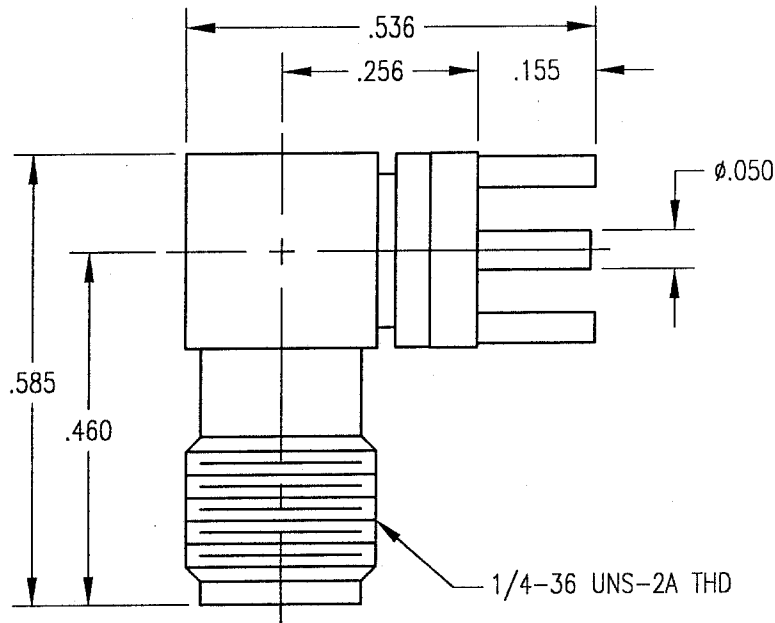

MOUNTING HOLE LAYOUT

NOTES:

1. MATERIALS:

BODY: BRASS PER ASTM B16
 CENTER CONTACT: BERYLLIUM COPPER PER ASTM B196
 INSERT: STAINLESS STEEL PER ASTM A582
 INSULATOR: TEFLON PER ASTM D1710

2. FINISH:

BODY: .000015 MIN. GOLD PER MIL-G-45204 OVER
 .000050 MIN. NICKEL PER QQ-N-290
 CENTER CONTACT: .000030 MIN. GOLD PER MIL-G-45204 OVER
 .000050 MIN. NICKEL PER QQ-N-290
 INSERT: .000005 MIN. GOLD PER MIL-G-45204 OVER
 .000050 MIN. NICKEL PER QQ-N-290

3. ELECTRICAL:

IMPEDANCE: 50 OHMS

PER ASME Y14.5M-1994 UNLESS OTHERWISE SPECIFIED: DIMENSIONS ARE IN INCHES (MM)		Litton	
TOLERANCES: DECIMALS .XX ± .01/0.254 XXX ± .005/0.127 ANGLES ± 2°		Winchester/Retconn 400 Park Road Waterbury, Connecticut 06785	
SCALE: 4:1		TITLE SMA RIGHT ANGLE PCB MOUNT RECEPTACLE	
CUSTOMER DRAWING		DRAWN DATE CHECKED DATE JED 2/7/00 JH 2-8-00	
APPROVED DATE APPROVED DATE [Signature] 2/7/00 KST [Signature]		A 353-060-0040H SH. OF REV. 1 1 A	