

# 1FI150B-060(150A)

# FAST RECOVERY DIODE MODULE

## 600V / 150A 1 in one-package

### FAST RECOVERY DIODE MODULE

#### ■ Features

- Short Reverse Recovery Time
- Variety of Connection Menu
- Insulated Type

#### ■ Applications

- Arc-Welders
- Free-Wheeling Diode
- High Speed Rectifiers

#### ■ Outline Drawings, mm

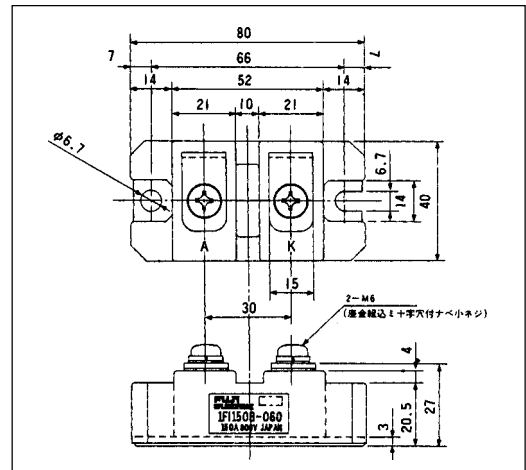

#### ■ Inner Circuit Schematic

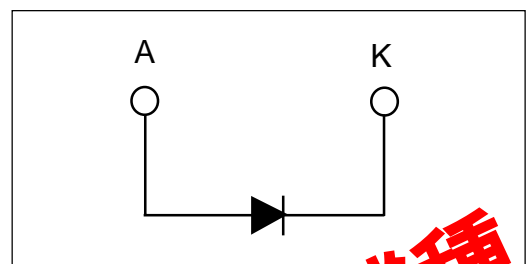

#### ■ Maximum ratings and characteristics

##### ● Absolute maximum ratings

Item	Symbol	Conditions	Rating	Unit
Repetitive peak reverse voltage	$V_{RRM}$		600	V
Non-repetitive peak reverse voltage	$V_{RSM}$		650	V
Average output current	$I_{F(AV)}$	50/60Hz Sine wave, $T_c=92^\circ\text{C}$	150	A
Surge current	$I_{FSM}$	From rated load Sine wave 10ms	2000	A
$I^2t$	$I^2t$	From rated load	16000	$\text{A}^2\text{s}$
Operating junction temperature	$T_j$		-40 to +150	$^\circ\text{C}$
Storage temperature	$T_{stg}$		-40 to +125	$^\circ\text{C}$
Isolation voltage	$V_{is}$		AC2000(1min.)	V
Screw torque	Terminals	(M6)	3.5	N·m
	Mountings	(M5)	2.5	N·m

##### ●Electrical characteristics ( $T_a=25^\circ\text{C}$ Unless otherwise specified)

Item	Symbol	Conditions	Min.	Typ.	Max.	Unit
Forward voltage drop	$V_{FM}$	$T_j=25^\circ\text{C}$ , $I_{FM}=150\text{A}$			1.10	V
Reverse current	$I_{RRM}$	$T_j=150^\circ\text{C}$ , $V_R=V_{RRM}$			15	mA
Reverse recovery time	$t_{rr}$	$T_j=25^\circ\text{C}$ , $I_F=75\text{A}$ , $-di/dt=375\text{A}/\mu\text{s}$			0.5	$\mu\text{s}$

##### ● Thermal Characteristics

Item	Symbol	Conditions	Min.	Typ.	Max.	Unit
Thermal resistance	$R_{th(j-c)}$	Junction to case			0.32	$^\circ\text{C}/\text{W}$
	$R_{th(c-f)}$	the base to cooling fin *			0.06	$^\circ\text{C}/\text{W}$

\* : With Thermal Compound

2007年3月 保守廃止予定機種  
 This product is scheduled be obsolete on march 2007.  
 Not recommend for new design.

■ Characteristics

Forward Characteristics

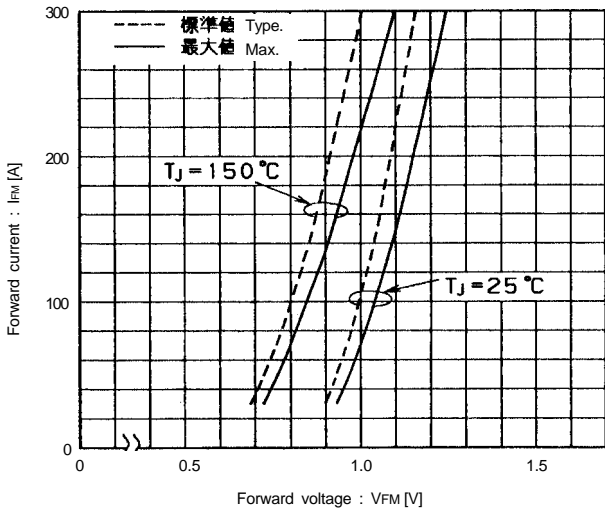

Output Current vs. Total Loss

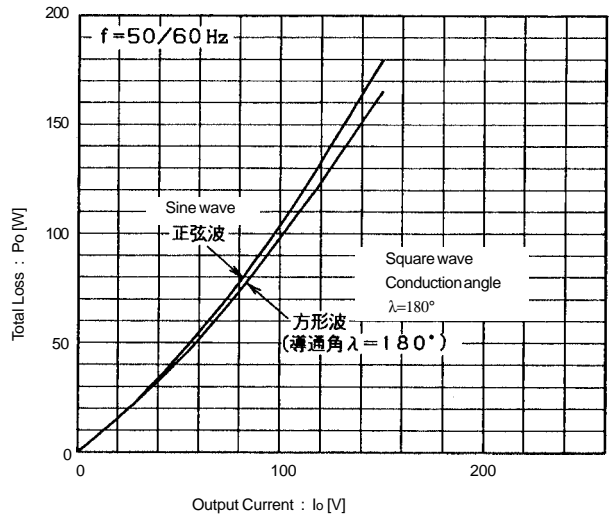

Reverse Recovery Characteristics

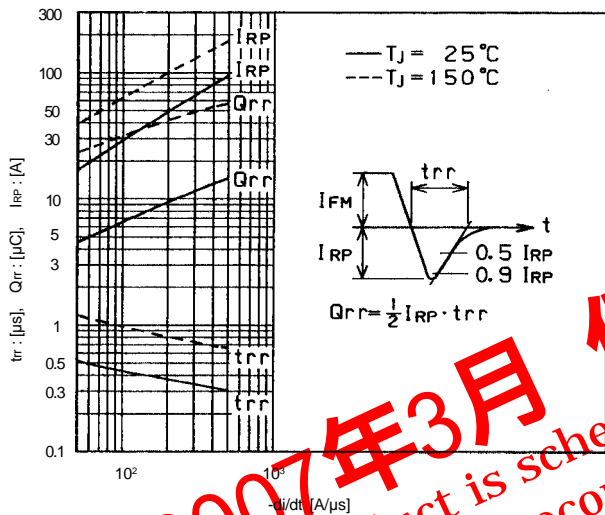

Surge Current

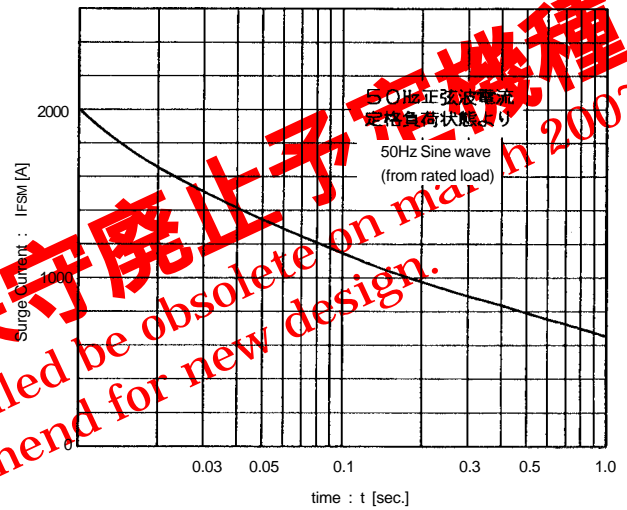

2007年3月 保守廃止予定機種  
 This product is scheduled to be obsolete on March 2007.  
 Not recommend for new design.

Transient Thermal Impedance

