

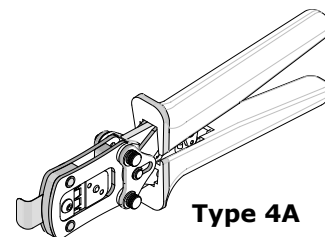

**Order Number  
213309-2000**

**Application Tooling Specification**



**FEATURES**

- A full cycle ratcheting hand tool ensures complete crimps
- Ergonomically designed soft handles
- Precisely designed crimping profiles with simple contact positioning
- Easy handling due to outstanding force ratio
- Modular crimp head is removable and can be used in the Electric Crimp Machine (Order No. 63816-1900), accompanied by Battery Powered Crimp Adapter (Order No. 63816-1950)
- Can also be used in the Battery Powered Tool Order No. 63816-0270 (110 V) or 63816-0280 (220 V), accompanied by Battery Powered Crimp Adapter (Order No. 63816-1950)

**SCOPE**

**Products:** TAK50 Receptacle Crimp Terminals, Small Grip, 0.13mm<sup>2</sup> wire.

Terminal Series No.	Terminal Order No. *	Wire Size			Insulation Diameter		Strip Length	
		AWG	mm <sup>2</sup>	Type	mm	In.	mm	In.
200096	200096-3201	-	0.13	CUSN-R3XLPE	0.95-1.05	.037-.041	3.60	.142
	200096-3261							

\* For reeled terminal part numbers, cut terminal from carrier strip with 0.20mm (.008") max cut-off tab length.

**DEFINITION OF TERMS**

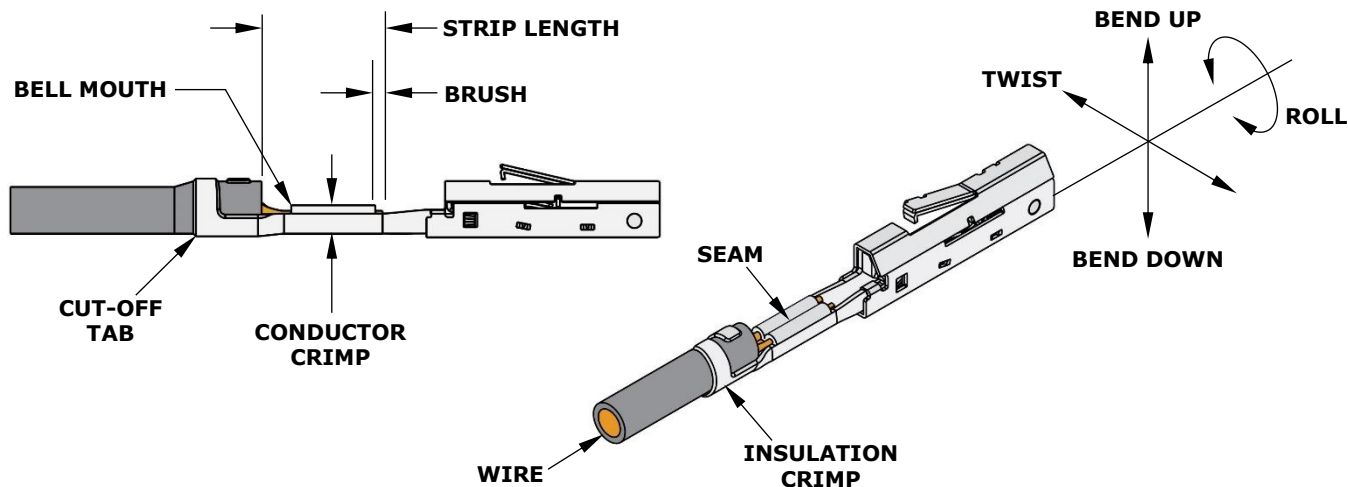

**CRIMP SPECIFICATION**

Terminal Series No.	Bell Mouth		Cut-Off Tab Maximum		Conductor Brush	
	mm	In.	mm	In.	mm	In.
200096	0.10-0.40	.004-.016	0.20	.008	0.30-0.70	.012-.028

Terminal Series No.	Bend Up	Bend Down	Twist	Roll	Punch Width (Ref)				Seam
					Conductor		Insulation		
	Degree (Max)	Degree (Max)	mm	In.	mm	In.			
200096	1	1	2	—	0.86	.034	1.01	.040	Seam shall not be open and no wire allowed out of the crimping area

After crimping, the conductor profile should measure the following:

Terminal Series No.	Wire Size		Conductor			
			Crimp Height		Crimp Width	
	AWG	mm <sup>2</sup>	mm	In.	mm	In.
200096	—	0.13	0.61-0.65	.024-.026	0.86-0.92	.034-.036

Terminal Series No.	Wire Size		Insulation				Pull Force Minimum	
			Crimp Height (Max)		Crimp Width (Max)			
	AWG	mm <sup>2</sup>	mm	In.	mm	In.	N	Lb.
200096	—	0.13	1.45	.057	1.17	.046	60	13.5

**Tool Qualification Notes**

1. (Ref) means the dimension provided is approximate due to the wide range of wires, conductor stranding, insulation diameter, and insulation hardness.
2. An occasional conductor crimp height measurement should be performed. It must lie between the minimum and maximum crimp height specification.
3. Pull force should be measured with no influence from the insulation crimp. To ensure this, strip the wire long enough so the terminal insulation grips do not contact the wire insulation.

**Notes**

1. This tool should only be used for the terminals and wire size specified on this sheet.
2. Variations in tools, terminals, wire stranding and insulation types may affect crimp height.
3. This tool is intended for metric (mm<sup>2</sup>) conductor sizes. It may not give good insulation crimp support for insulation sizes outside of the specified range.
4. Molex does not repair hand tools (see warranty above). The replacement parts listed are the only parts available for repair. If the handles or crimp tooling become damaged or worn, a new tool must be purchased.
5. Conductor crimp height should be used as the final criterion for an acceptable crimp. Refer to Molex Quality Crimping Handbook 63800-0029 for additional information on crimping and crimp testing.
6. Molex does not certify hand crimp tools.

## OPERATION

Open the tool by squeezing the handles together. At the end of the closing stroke, the ratchet mechanism will release the handles, and the hand tool will spring open.

1. With the hand tool in the open position, pivot the terminal locator open by pulling up on the locator knob, and lift the wire stop blade. See Figure 1.
2. Insert the terminal into the locator until the terminal is fully seated and stops. Make sure the wire stop blade is fully raised.
3. Gently pivot the locator closed.
4. Bring down the wire stop blade until it is fully seated on the terminal.
5. Slide the pre-stripped wire into the terminal, making sure to aim the wire brush toward the tip point on the wire stop blade. See Figure 2. Align the wire so that it is parallel and resting in the terminal. Maintain a light and constant pressure on the wire against the wire stop blade (do not let go of the wire).  
See Figure 3.
6. Close the tool until the ratchet releases.
7. Lift the wire stop blade.
8. Carefully remove the crimped terminal from the locator.

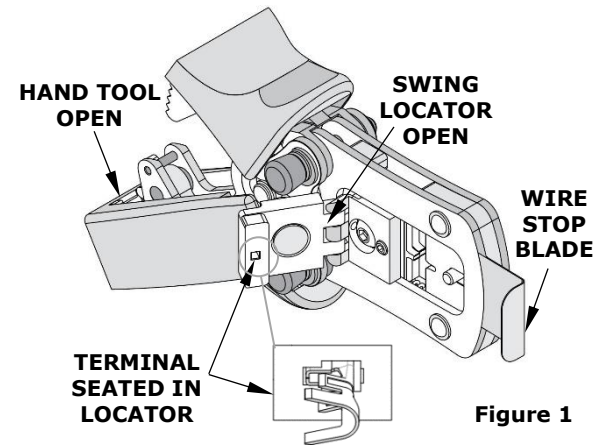

Figure 1

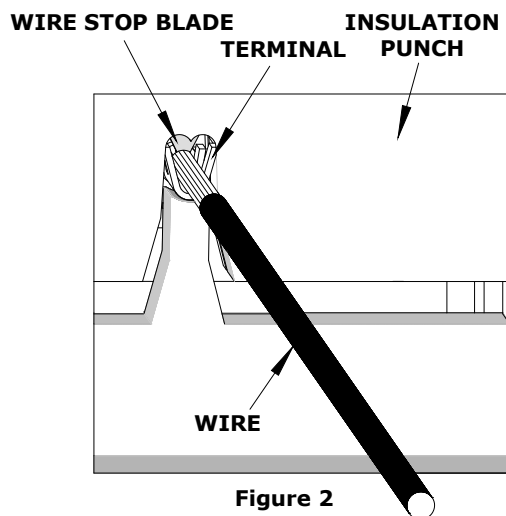

Figure 2

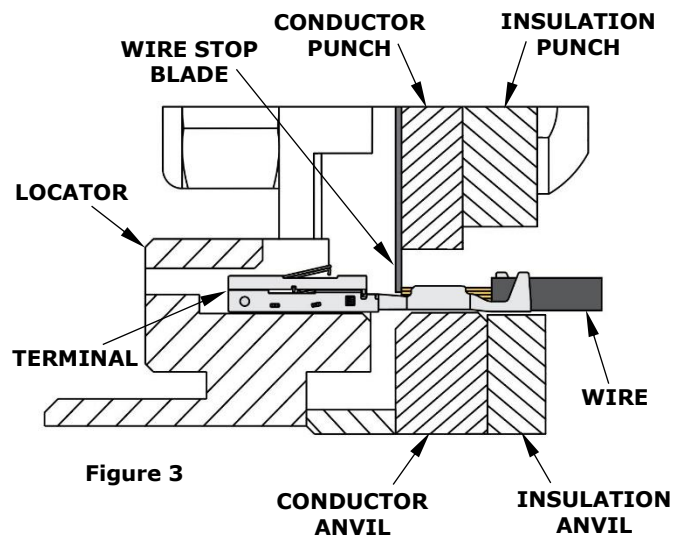

Figure 3

**Note:** The tamper-proof ratchet action will not release the tool until it has been fully closed.

**Note:** To maintain good brush control and a consistent bell mouth, the crimping instructions must be followed.

## TERMINAL LOCATOR REPLACEMENT

This section describes the procedure for changing locators.

### Removal

1. With the tool in the open position, pivot the terminal locator outward.
2. Remove the M4 BHCS. See Figure 4.

### Installation

1. Place the locator on the hand tool. Install the M4 BHCS. See Figure 4.
2. Tighten the screw just enough to hold the locator. Make sure the locator can still float freely with hand pressure.
3. Insert the proper terminal fully into the correct profile slot until the terminal is fully seated and stops. Then, gently pivot the locator closed.
4. With hand pressure, slowly slide the locator to the correct position. See Figure 5.
5. Gently pivot the locator open without disturbing the location.
6. Hold the locator firmly in place, and slowly tighten the M4 BHCS.

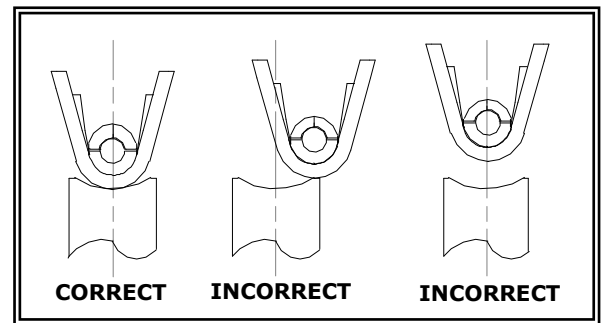
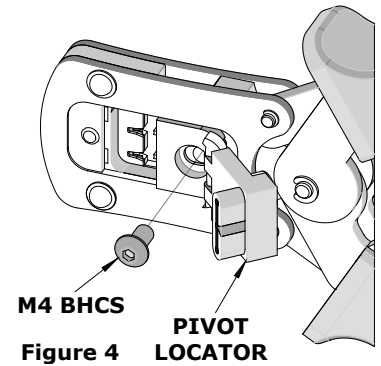

Figure 5

## MAINTENANCE

It is recommended that each operator of the tool be made aware of and responsible for the following maintenance steps:

1. Remove dust, moisture and other contaminants with a clean brush or a soft, lint-free cloth.
2. Do not use any abrasive materials that could damage the tool.
3. Make certain all pins, pivot points and bearing surfaces are protected with a thin coat of high-quality machine oil. Do not oil excessively. The tool was engineered for durability, but like any other equipment, it needs cleaning and lubrication for a maximum service life of trouble-free crimping. Light oil (such as 30 weight automotive oil) used at the oil points every 5,000 crimps or 3 months will significantly enhance the tool life.
4. Wipe excess oil from the hand tool, particularly from the crimping area. Oil transferred from the crimping area onto certain terminations may affect the electrical characteristics of an application.
5. When the tool is not in use, keep the handles closed to prevent objects from becoming lodged in the crimping dies, and store the tool in a clean, dry area.

### Miscrimps or Jams

Should this tool ever become stuck or jammed in a partially closed position, **do not force the handles open or shut**. The tool will open easily by lifting the ratchet release lever. See Figure 9.

### Warranty

This tool is for electrical terminal crimping purposes only. This tool is made of the best quality materials. All vital components are long-life tested. All tools are warranted to be free of manufacturing defects for a period of 30 days. Should such a defect occur, Molex will repair or exchange the tool free of charge. This repair or exchange will not be applicable to altered, misused or damaged tools. This tool is designed for hand use only. Any clamping, fixturing or use of handle extensions voids this warranty.

**CAUTION:** Repetitive use of this tool should be avoided.

**CAUTIONS**

1. Manually powered hand tools are intended for low-volume use or field repair. This tool is **NOT** intended for production use. Repetitive use of this tool should be avoided.
2. Insulated rubber handles are not protection against electrical shock.
3. Wear eye protection at all times.
4. Use only the Molex terminals specified for crimping with this tool.

**CAUTION:** Molex crimp specifications are valid only when used with Molex terminals and tooling.

**APPLICATIONS FOR THE MODULAR CRIMP HEAD**

**WARNING:** NEVER operate, service, install or adjust this Modular Crimp Head without proper instruction and without first reading and understanding the instructions in the proper manual or specification sheet. See chart below for the correct manual or specification sheet.

**WARNING:** NEVER install tooling or service this tool while it is plugged into any power source. Disconnect the power by unplugging, or turn off the actuator from its power source.

**CAUTION:** Keep fingers away from the crimping area when operating this tool. It may cause severe injury.

**CAUTION:** Wear safety glasses when operating or servicing this tool.

The chart below shows all applications for this modular crimp head:

Tool Order No.	Tool Description	Adapter Order No.	Adapter Description	Figure No.
63816-0000	Hand Crimp Frame (Short)	—	—	6
63816-0050	Hand Crimp Frame (Long)	—	—	6
63816-0270	Battery Power Tool (110 V)	63816-1950	Battery Power Crimp Adapter	7
63816-0280	Battery Power Tool (220 V)	63816-1950	Battery Power Crimp Adapter	7
63816-1900	Electric Crimp Machine	63816-1950	Battery Power Crimp Adapter	8

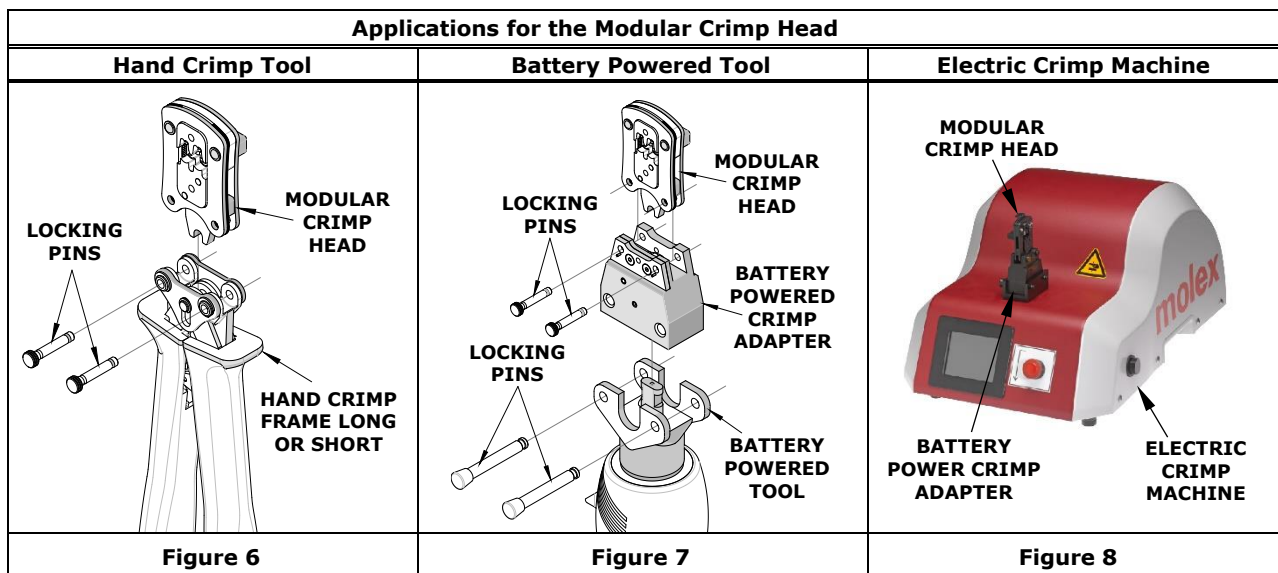

**PARTS LIST**

Item	Order Number	Description	Quantity
1	63816-0000	Hand Crimp Frame (Short)	1
2	213309-2075	Terminal Locator	1
3	63816-0001	Locking Pin	2
4	63600-0525	Handle Spring	1
5	63600-0520	Crimping Spring	2

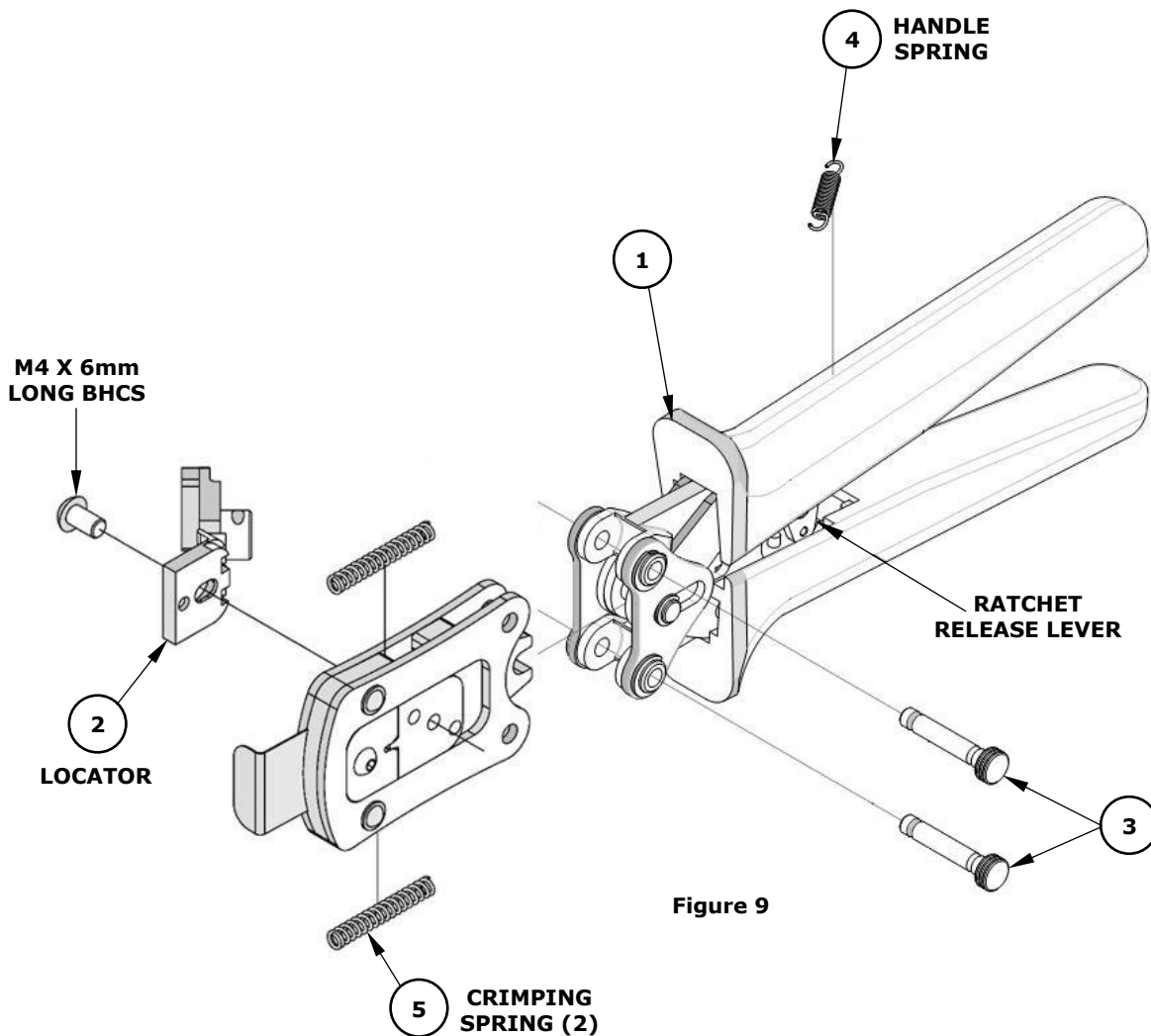

**Application Tooling Support**

**Phone:** (402) 458-TOOL (8665)  
**E-Mail:** applicationtooling@molex.com  
**Website:** www.molex.com/applicationtooling

Molex is a registered trademark of Molex, LLC in the United States of America and may be registered in other countries; all other trademarks listed herein belong to their respective owners.