

High-Efficiency μ Module Non-Isolated POL DC-DC Converter

Bellnix[®] BSU-1.8S3R0

FEATURES:

- High Density μ POL Module
- 3A Output Current
- Input Voltage Range from 2.7V to 5.5V
- Output Voltage Range from 0.6V to 3.3V
- 95% Peak Efficiency at 5VIN
- Adjustable Output Voltage
- Enable / PGOOD Function
- Automatic Power Saving/PWM Mode
- Protections (UVLO, OCP: Non-latching)
- Internal Soft Start
- Compact Size: 3.0mm*3.7mm*1.2mm
- Pb-free for RoHS compliant
- MSL 2, 260°C Reflow

APPLICATIONS:

- Single Li-Ion Battery-Powered Equipment
- LDOs Replacement
- Cell Phones / PDAs / Palmtops

GENERAL DESCRIPTION:

The μ POL module is non-isolated dc-dc converters that can deliver up to 3A of output current. The PWM switching regulator, high frequency power inductor are integrated in one hybrid package. It only need input/output capacitors and one voltage dividing resistor.

The module has automatic operation with PWM mode and power saving mode according to loading, through constant on-time control, the module offers a simpler control loop and faster transient response. Other features include remote enable function, internal soft-start, non-latching over current protection, power good, and input under voltage locked-out capability.

The low profile and compact size package (3.0mm \times 3.7mm \times 1.2mm) is suitable for automated assembly by standard surface mount equipment. The μ POL module is Pb-free and RoHS compliance.

TYPICAL APPLICATION CIRCUIT & PACKAGE:

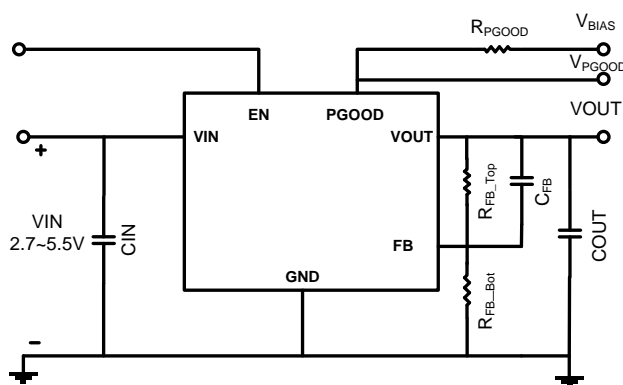

FIGURE.1 TYPICAL APPLICATION CIRCUIT

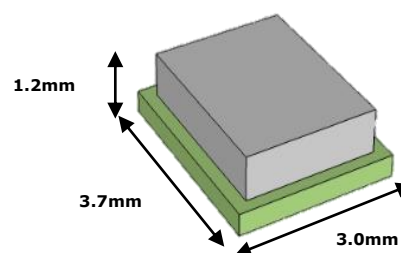

FIGURE.2 HIGH DENSITY LOW PROFILE
 μ POL MODULE

High-Efficiency μ Module Non-Isolated POL DC-DC Converter

Bellnix[®] BSU-1.8S3R0

ELECTRICAL SPECIFICATIONS:

CAUTION: Do not operate at or near absolute maximum rating listed for extended periods of time. This stress may adversely impact product reliability and result in failures not covered by warranty.

Parameter	Description	Min.	Typ.	Max.	Unit
■ Absolute Maximum Ratings					
VIN to GND		-0.2	-	+6.0	V
VOUT to GND		-0.2	-	+6.0	V
SW to GND		-		VIN+0.3	V
EN to GND		-0.2	-	+6.0	V
Tc	Case Temperature of Inductor	-	-	+110	°C
Tj	Junction Temperature	-40	-	+150	°C
Tstg	Storage Temperature	-40	-	+125	°C
ESD Rating	Human Body Model (HBM)	-	-	2k	V
	Machine Model (MM)	-	-	200	V
	Charge Device Model (CDM)	-	-	500	V
■ Recommendation Operating Ratings					
VIN	Input Supply Voltage	+2.7	-	+5.5	V
VOUT	Adjusted Output Voltage	0.6		+3.3	V
Ta	Ambient Temperature	-40	-	+85	°C
■ Thermal Information					
Rth(jchoke-a)	Thermal resistance from junction to ambient (Note 1)	-	25	-	°C/W

NOTES:

1. Rth(jchoke-a) is measured with the component mounted on an effective thermal conductivity test board on 0 LFM condition. The test board size is 76.2mm×76.2mm×1.6mm, 4 layers. The test condition is complied with JEDEC E11/JESD 51 Standards.

High-Efficiency μ Module Non-Isolated POL DC-DC Converter

Bellnix® BSU-1.8S3R0

ELECTRICAL SPECIFICATIONS: (Cont.)

Conditions: $T_A = 25\text{ }^\circ\text{C}$, unless otherwise specified. Test Board Information: 76.2mm \times 76.2mm \times 1.6mm, 4 layers. The output ripple and transient response measurement is short loop probing and 20MHz bandwidth limited.

$V_{in} = 3.3\text{V}$, $V_{out} = 1.8\text{V}$

$C_{in} = 22\mu\text{F}/6.3\text{V}$ 1206x1 47 $\mu\text{F}/6.3\text{V}$ 1206x1, $C_{out} = 47\mu\text{F}/6.3\text{V}$ 1206x1, unless otherwise specified.

Symbol	Parameter	Conditions	Min.	Typ.	Max.	Unit
■ Input Characteristics						
$I_{SD(IN)}$	Input shutdown current	$V_{in} = 3.3\text{V}$, $EN = \text{GND}$	-	50	-	μA
$I_{Q(IN)}$	Input supply bias current	$V_{in} = 3.3\text{V}$, $I_{out} = 0\text{A}$ $EN = V_{in}$ $V_{out} = 1.8\text{V}$	-	120	-	μA
$I_{S(IN)}$	Input supply current	$V_{in} = 3.3\text{V}$, $EN = V_{in}$	-	-	-	-
		$I_{out} = 5\text{mA}$ $V_{out} = 1.8\text{V}$	-	3.2	-	mA
		$I_{out} = 1.5\text{A}$ $V_{out} = 1.8\text{V}$	-	0.91	-	A
		$I_{out} = 3.0\text{A}$ $V_{out} = 1.8\text{V}$	-	2	-	A
■ Output Characteristics						
$I_{OUT(DC)}$	Output continuous current range	$V_{in}=3.3\text{V}$, $V_{out}=1.8\text{V}$	0	-	3	A
$V_{O(SET)}$	Output Voltage Set Point	With 0.5% tolerance for external resistor used to set output voltage	-3.0	-	+3.0	% $V_{O(SET)}$
$\frac{\Delta V_{OUT}}{\Delta V_{IN}}$	Line regulation accuracy	$V_{in} = 3.3\text{V}$ to 5V $V_{out} = 1.8\text{V}$, $I_{out} = 3.0\text{A}$	-	0.1	-	% $V_{O(SET)}$
$\frac{\Delta V_{OUT}}{\Delta I_{OUT}}$	Load regulation accuracy	$I_{out} = 0\text{A}$ to 3.0A $V_{in} = 3.3\text{V}$, $V_{out} = 1.8\text{V}$	-	0.5	-	% $V_{O(SET)}$
$V_{OUT(AC)}$	Output ripple voltage	$V_{in} = 3.3\text{V}$, $V_{out} = 1.8\text{V}$ $EN = V_{in}$	-	-	-	-
		$I_{OUT} = 5\text{mA}$,	-	50	-	mVp-p
		$I_{OUT} = 3.0\text{A}$,	-	15	-	mVp-p
$C_{OUT(MAX)}$	Maximum capacitive load	$I_{out} = 3.0\text{A}$, $ESR \geq 1\text{ m}\Omega$	-	-	150	μF

ELECTRICAL SPECIFICATIONS: (Cont.)

Conditions: $T_A = 25\text{ }^\circ\text{C}$, unless otherwise specified. Test Board Information: 76.2mm \times 76.2mm \times 1.6mm, 4 layers. The output ripple and transient response measurement is short loop probing and 20MHz bandwidth limited.

$V_{in} = 3.3\text{V}$, $V_{out} = 1.8\text{V}$

$C_{in} = 22\mu\text{F}/6.3\text{V } 1206 \times 1$, $47\mu\text{F}/6.3\text{V } 1206 \times 1$, $C_{out} = 47\mu\text{F}/6.3\text{V}/ 1206 \times 1$, unless otherwise specified.

Symbol	Parameter	Conditions	Min.	Typ.	Max.	Unit
■ Control Characteristics						
V_{EN_TH}	Enable upper threshold voltage	V_{EN_TH} rising	1.2	-	-	V
	Enable lower threshold voltage	V_{EN_TH} falling	-	-	0.4	V
F_{OSC}	Oscillator frequency	Note 1, PWM Operation	-	1.2	-	MHz
V_{REF}	Referance voltage	Note 1	-2.0%	0.600	+2.0%	V/%
V_{PGOOD_TH}	PGOOD threshold voltage	Upper trip, V_{REF} respect to the regulation, Note 1	-	+10%	-	%
		Lower trip, V_{REF} respect to the regulation, Note 1	-	-10%	-	%
V_{PGOOD_L}	PGOOD sink current capability	Sink 1mA			0.4	V
V_{PGOOD_H}	PGOOD logic high voltage	$V_{IN}=3.3\text{V}$, $V_{FB}=0.6\text{V}$	3.2			V
■ Fault Protection						
I_{LIMIT_TH}	Current limit threshold	Peak value of inductor current,	4.2		6	A
T_{OTP}	Over temperature protection		-	150	-	$^\circ\text{C}$

PIN CONFIGURATION:

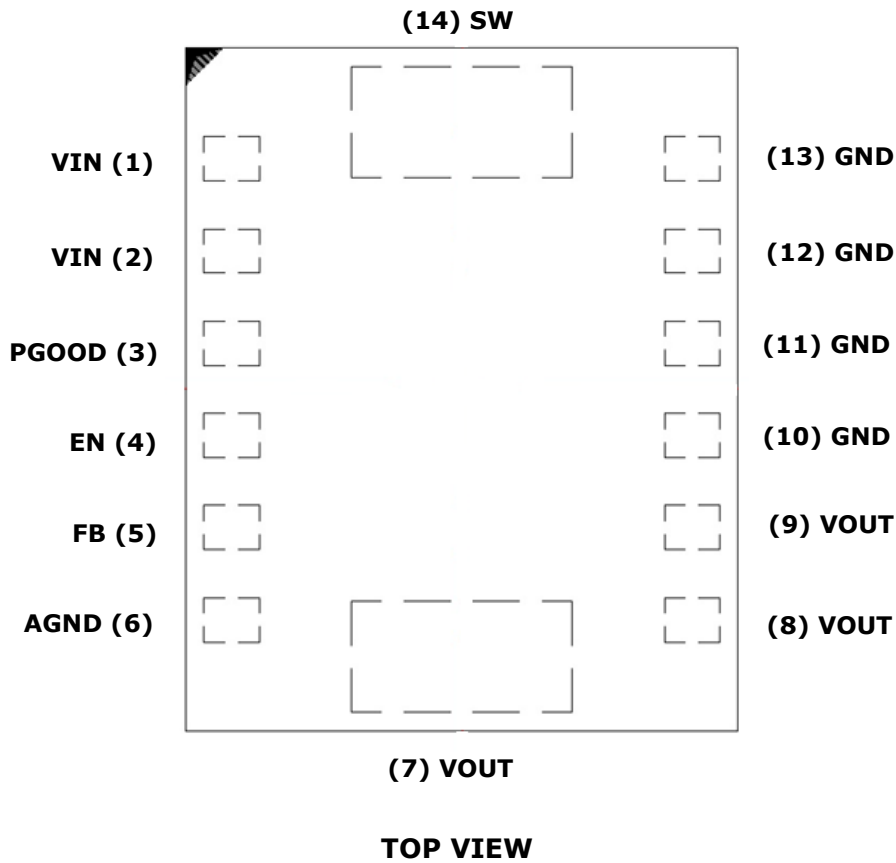

PIN DESCRIPTION:

Symbol	Pin No.	Description
VIN	1, 2	Power input pin. It needs to connect input rail.
PGOOD	3	Power Good indicator. The pin output is an open drain that connects to VIN by an internal pull-up resistor. PG is pulled up to VIN when the FB voltage is within 10% of the regulation level. If FB voltage is out of that regulation range, it is LOW.
EN	4	On/Off control pin for module. EN = LOW, the module is off. EN = HIGH, the module is on.
FB	5	Feedback input. Connect an external resistor divider from the output to GND to set the output voltage.
AGND	6	Analog ground.
VOUT	7, 8, 9	Power output pin. Connect to output for the load.
GND	10, 11, 12, 13	Power ground pin for signal, input, and output return path. This pin needs to connect one or more ground plane directly.
SW	14	Switch output

TYPICAL PERFORMANCE CHARACTERISTICS: (1.0VOUT)

Conditions: $T_A = 25\text{ }^\circ\text{C}$, unless otherwise specified. Test Board Information: 76.2mm \times 76.2mm \times 1.6mm, 4 layers. The output ripple and transient response measurement is short loop probing and 20MHz bandwidth limited. $C_{in} = 22\mu\text{F}/6.3\text{V}$ 1206 \times 1, $47\mu\text{F}/6.3\text{V}$ 1206 \times 1 $C_{out} = 47\mu\text{F}/6.3\text{V}/1206\text{ } \times$ 1

The following figures provide the typical characteristic curves at 1.0Vout.

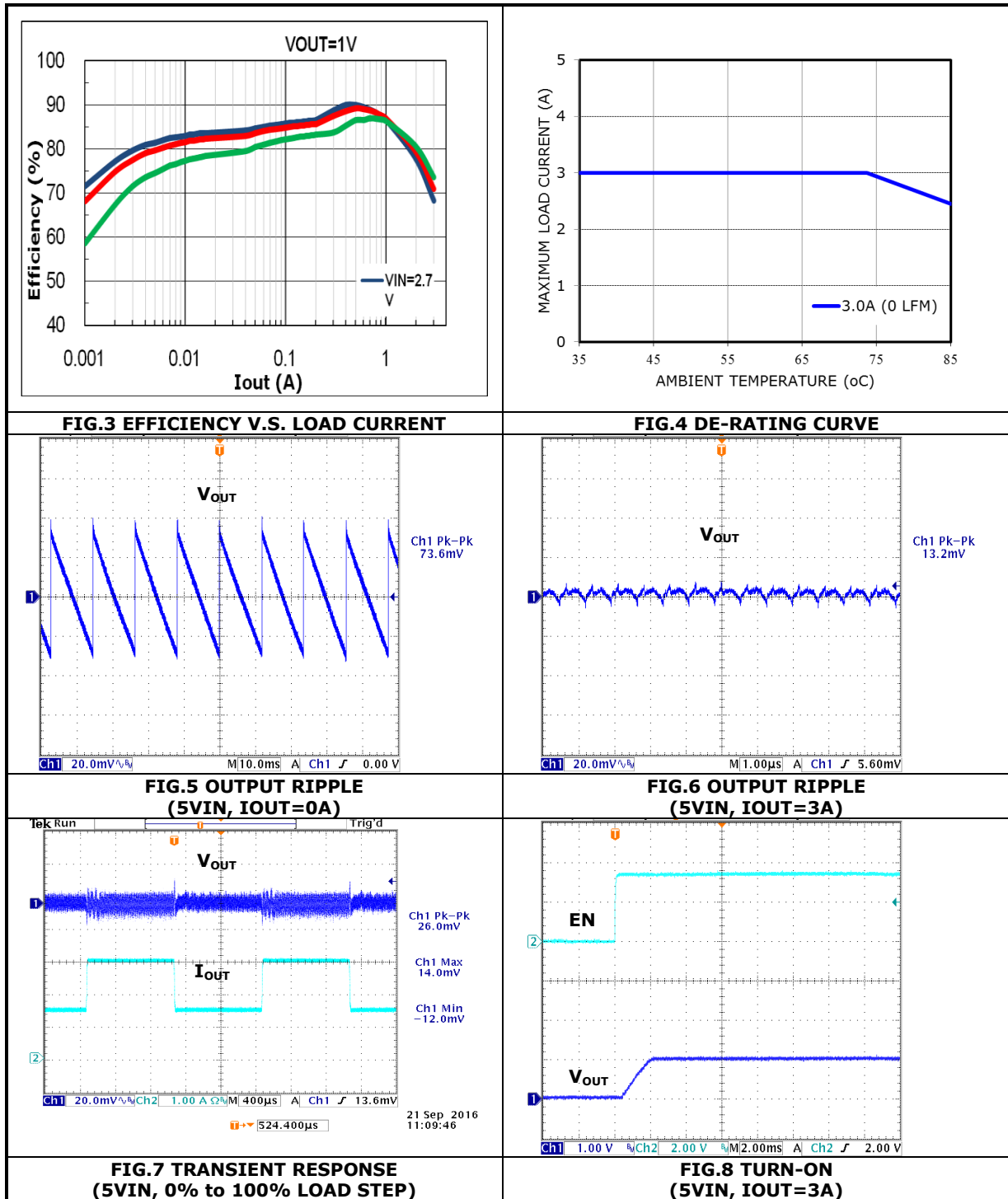

High-Efficiency μ Module Non-Isolated POL DC-DC Converter

Bellnix[®] BSU-1.8S3R0

TYPICAL PERFORMANCE CHARACTERISTICS: (1.2V_{OUT})

Conditions: $T_A = 25\text{ }^\circ\text{C}$, unless otherwise specified. Test Board Information: 76.2mm \times 76.2mm \times 1.6mm, 4 layers. The output ripple and transient response measurement is short loop probing and 20MHz bandwidth limited. $C_{in} = 22\mu\text{F}/6.3\text{V}$ 1206 \times 1, $47\mu\text{F}/6.3\text{V}$ 1206 \times 1 $C_{out} = 47\mu\text{F}/6.3\text{V}$ 1206 \times 1
 The following figures provide the typical characteristic curves at 1.2V_{out}.

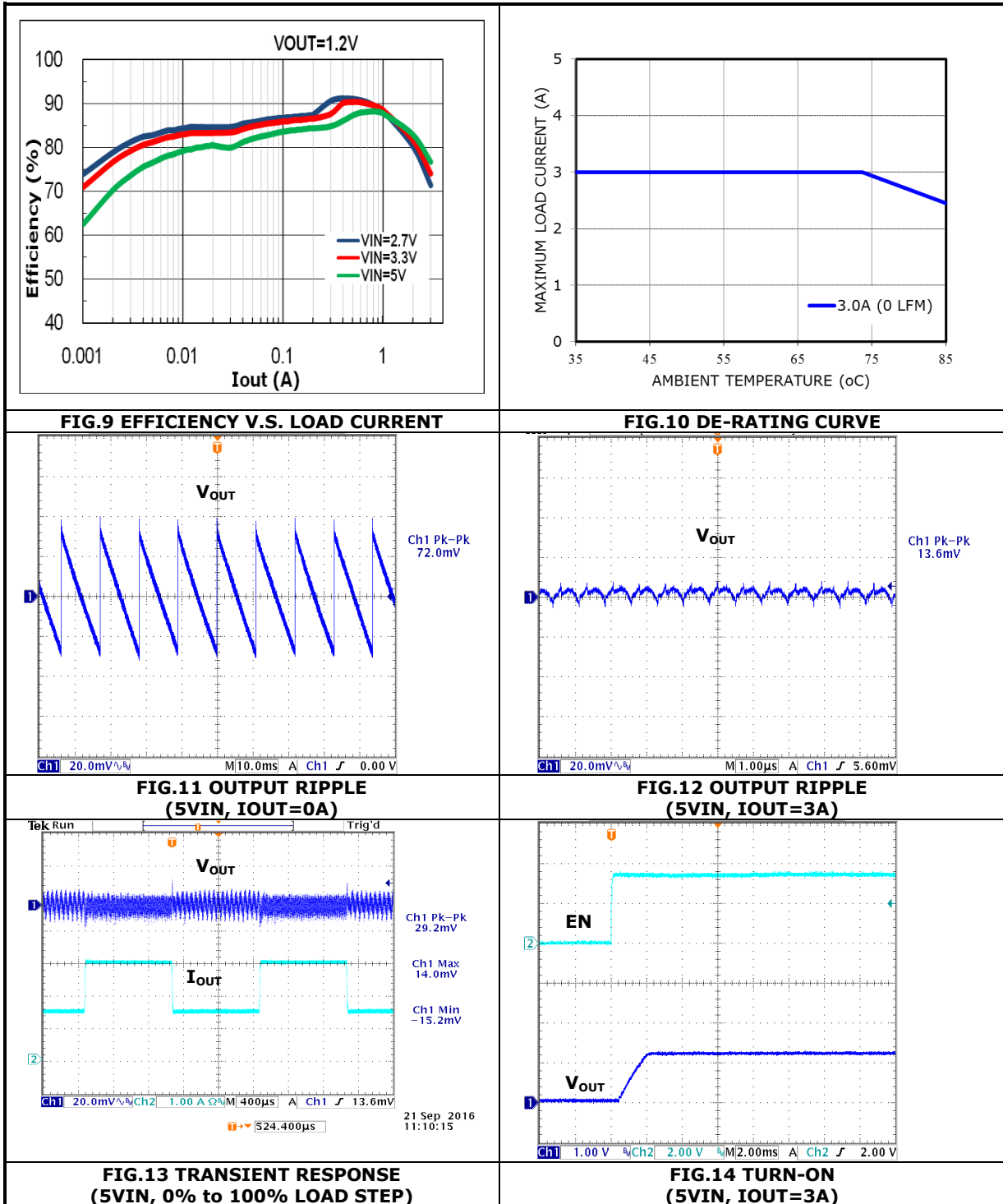

TYPICAL PERFORMANCE CHARACTERISTICS: (1.8VOUT)

Conditions: $T_A = 25\text{ }^\circ\text{C}$, unless otherwise specified. Test Board Information: 76.2mm \times 76.2mm \times 1.6mm, 4 layers. The output ripple and transient response measurement is short loop probing and 20MHz bandwidth limited. $C_{in} = 22\mu\text{F}/6.3\text{V } 1206\times 1$, $47\mu\text{F}/6.3\text{V } 1206\times 1$ $C_{out} = 47\mu\text{F}/6.3\text{V}/ 1206\times 1$
 The following figures provide the typical characteristic curves at 1.8Vout.

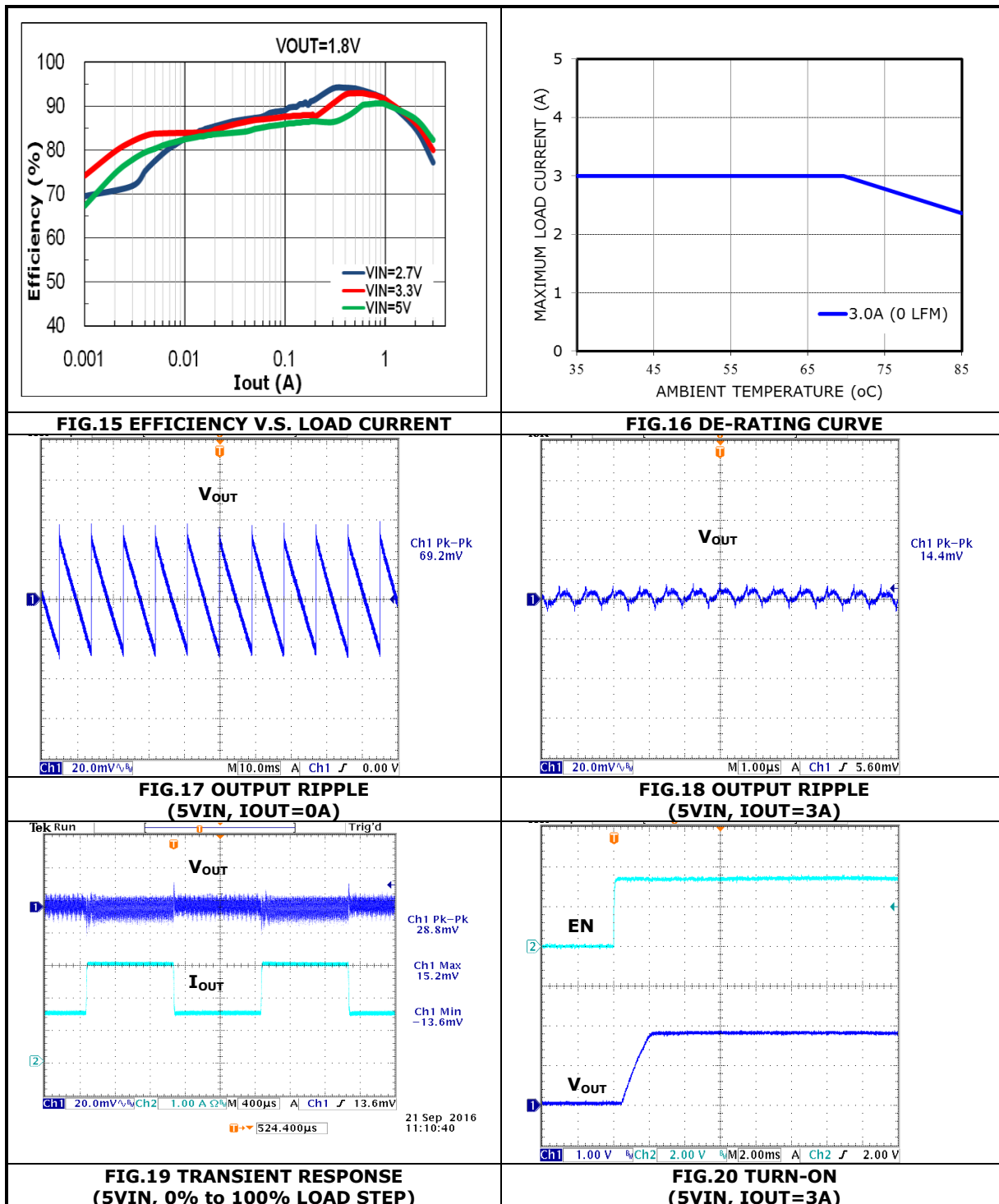

TYPICAL PERFORMANCE CHARACTERISTICS: (2.5V_{OUT})

Conditions: $T_A = 25\text{ }^\circ\text{C}$, unless otherwise specified. Test Board Information: 76.2mm \times 76.2mm \times 1.6mm, 4 layers. The output ripple and transient response measurement is short loop probing and 20MHz bandwidth limited. $C_{in} = 22\mu\text{F}/6.3\text{V } 1206\times 1$, $47\mu\text{F}/6.3\text{V } 1206\times 1$ $C_{out} = 47\mu\text{F}/6.3\text{V}/ 1206\times 1$
 The following figures provide the typical characteristic curves at 2.5V_{out}.

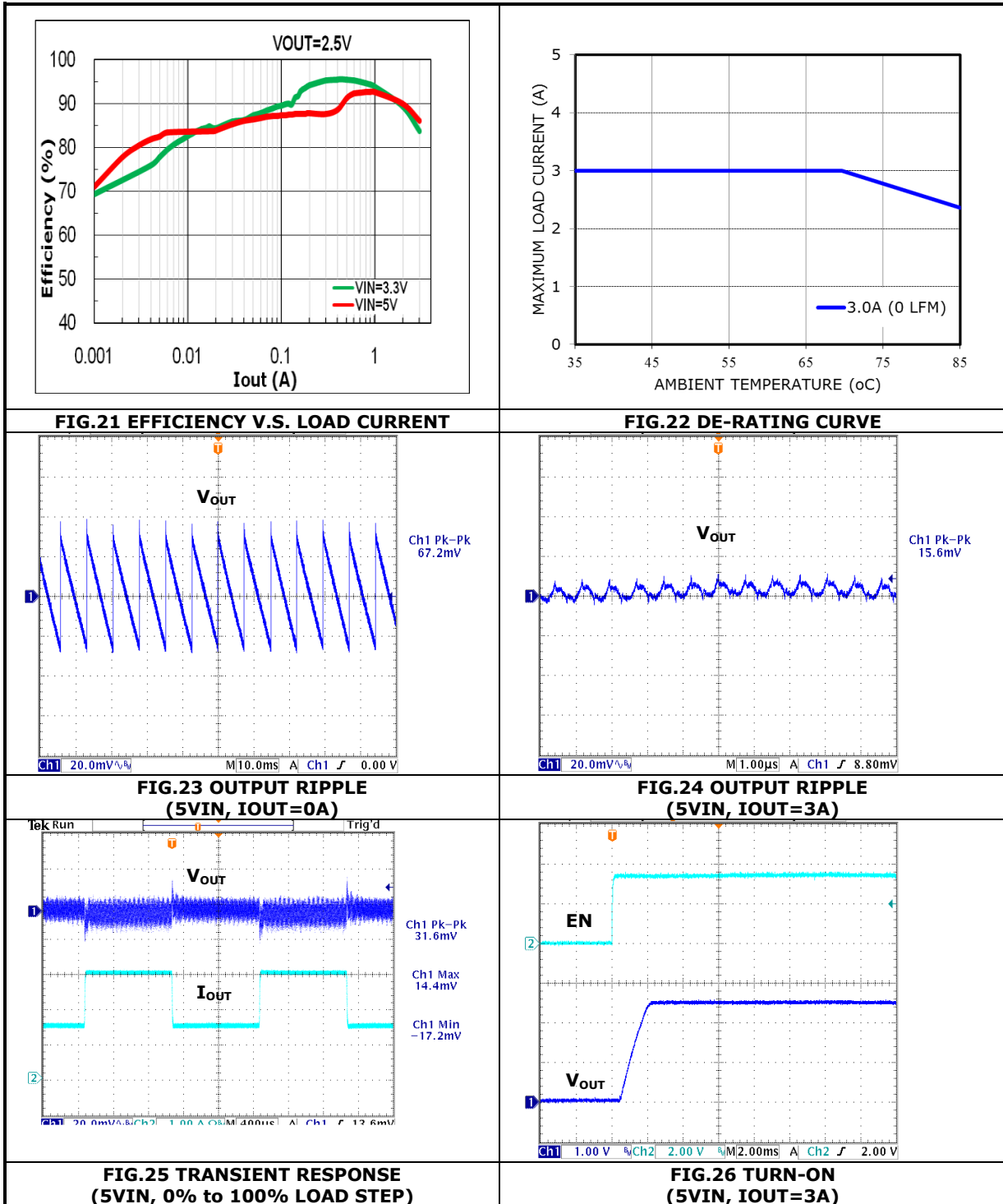

TYPICAL PERFORMANCE CHARACTERISTICS: (3.3V_{OUT})

Conditions: $T_A = 25\text{ }^\circ\text{C}$, unless otherwise specified. Test Board Information: 76.2mm \times 76.2mm \times 1.6mm, 4 layers. The output ripple and transient response measurement is short loop probing and 20MHz bandwidth limited. $C_{in} = 22\mu\text{F}/6.3\text{V}$ 1206 \times 1, $47\mu\text{F}/6.3\text{V}$ 1206 \times 1 $C_{out} = 47\mu\text{F}/6.3\text{V}$ 1206 \times 1
 The following figures provide the typical characteristic curves at 3.3V_{out}.

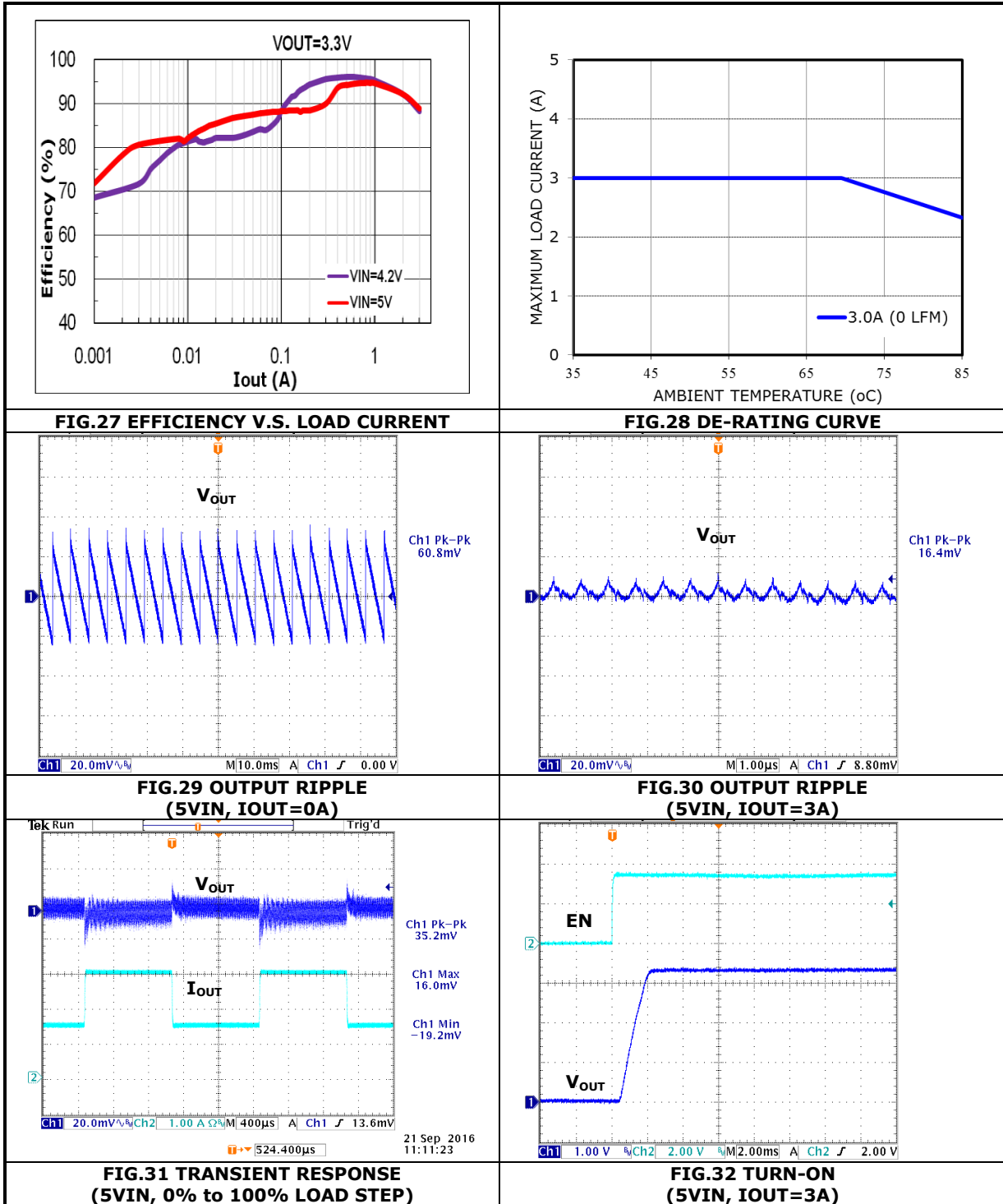

APPLICATIONS INFORMATION:

REFERENCE CIRCUIT FOR GENERAL APPLICATION:

The Figure 33 shows the module application schematics for input voltage +5V or +3.3V and turn on by input voltage directly through enable resistor (REN).

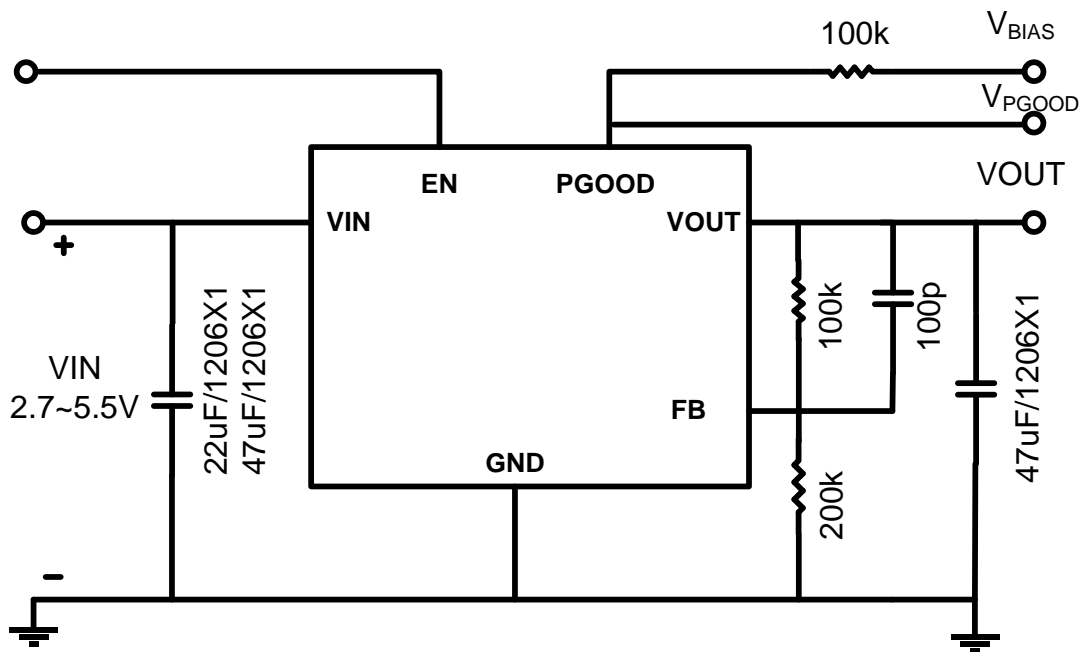

FIG.33 REFERENCE CIRCUIT FOR GENERAL APPLICATION

APPLICATIONS INFORMATION: (Cont.)

SAFETY CONSIDERATIONS:

Certain applications and/or safety agencies may require fuses at the inputs of power conversion components. Fuses should also be used when there is the possibility of sustained input voltage reversal which is not current limited. For greatest safety, we recommend a fast blow fuse installed in the ungrounded input supply line. The installer must observe all relevant safety standards and regulations. For safety agency approvals, install the converter in compliance with the end-user safety standard.

INPUT FILTERING:

The module should be connected to a low AC impedance source supply and a highly inductive source or line inductance can affect the stability of the module. An input capacitor must be placed directly to the input pin of the module, to minimize input ripple voltage and ensure module stability.

OUTPUT FILTERING:

To reduce output ripple and improve the dynamic response to as step load change, the additional capacitor at the output must be used. Low ESR polymer and ceramic capacitors are recommended to improve the output ripple and dynamic response of the module.

PROGRAMMING OUTPUT VOLTAGE:

The module has an internal $0.6V \pm 2\%$ reference voltage. The output voltage can be programmed by the dividing resistance RFB which respects to FB pin and GND pin. The output voltage can be calculated as shown in Equation 1 and the resistor according to typical output voltage is shown in TABLE 1.

$$V_{OUT} (V) = 0.6 \times \left(1 + \frac{R_{FB_top}}{R_{FB_bot}} \right) \tag{EQ.1}$$

Vout (V)	RFB_top (k Ω)	RFB_bot (k Ω)
1.0	200(1%)	300(1%)
1.2	200(1%)	200(1%)
1.8	200(1%)	100(1%)
2.5	200(1%)	63.2(1%)
3.3	200(1%)	44.2(1%)

TABLE.01 Resistor values for common output voltages

APPLICATIONS INFORMATION: (Cont.)

RECOMMENDATION LAYOUT GUIDE:

In order to achieve stable, low losses, less noise or spike, and good thermal performance some layout considerations are necessary. The recommendation layout is shown as Figure 34.

1. The ground connection between pin 10 and 13 should be a solid ground plane under the module. It can be connected to one or more ground plane by using several Vias.
2. Keep the R_{FB_top} and R_{FB_bot} connection trace to the module pin 5 (FB) short.
3. Use large copper area for power path (VIN, VOUT, and GND) to minimize the conduction loss and enhance heat transferring. Also, use multiple Vias to connect power planes in different layers.

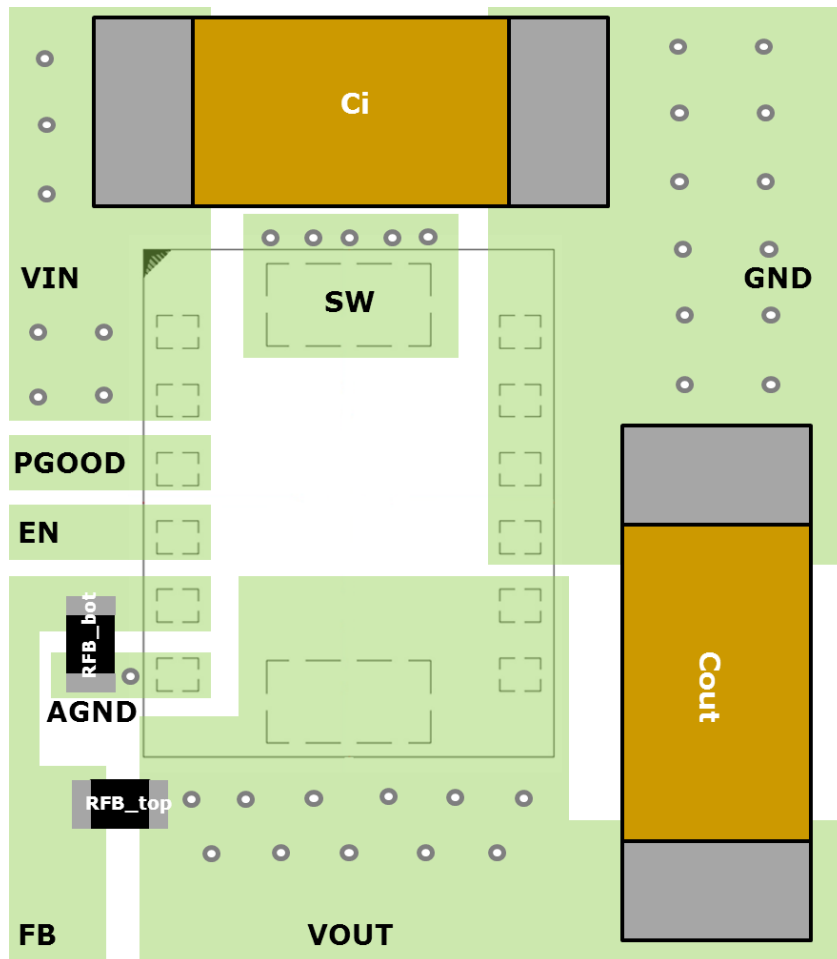

FIG.34 RECOMMENDATION LAYOUT (TOP LAYER)

APPLICATIONS INFORMATION: (Cont.)

Thermal Considerations:

All thermal testing condition is complied with JEDEC EIJ/JESD 51 Standards. Therefore, the test board size is 76.2mm× 76.2mm× 1.6mm with 4 layers. The case temperature of module sensing point is shown as Figure 35. Then $R_{th(j_{choke}-a)}$ is measured with the component mounted on an effective thermal conductivity test board on 0 LFM condition. The BSU-1.8S3R0 power module is designed for using when the case temperature is below 110°C regardless the change of output current, input/output voltage or ambient temperature.

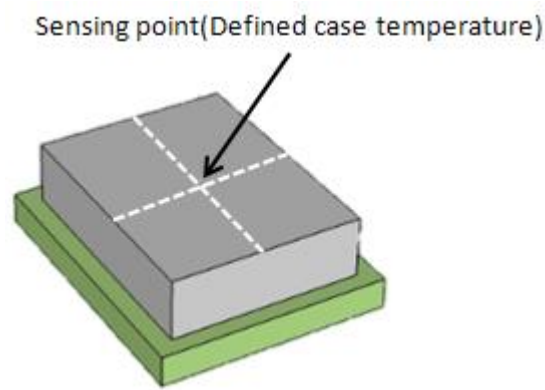
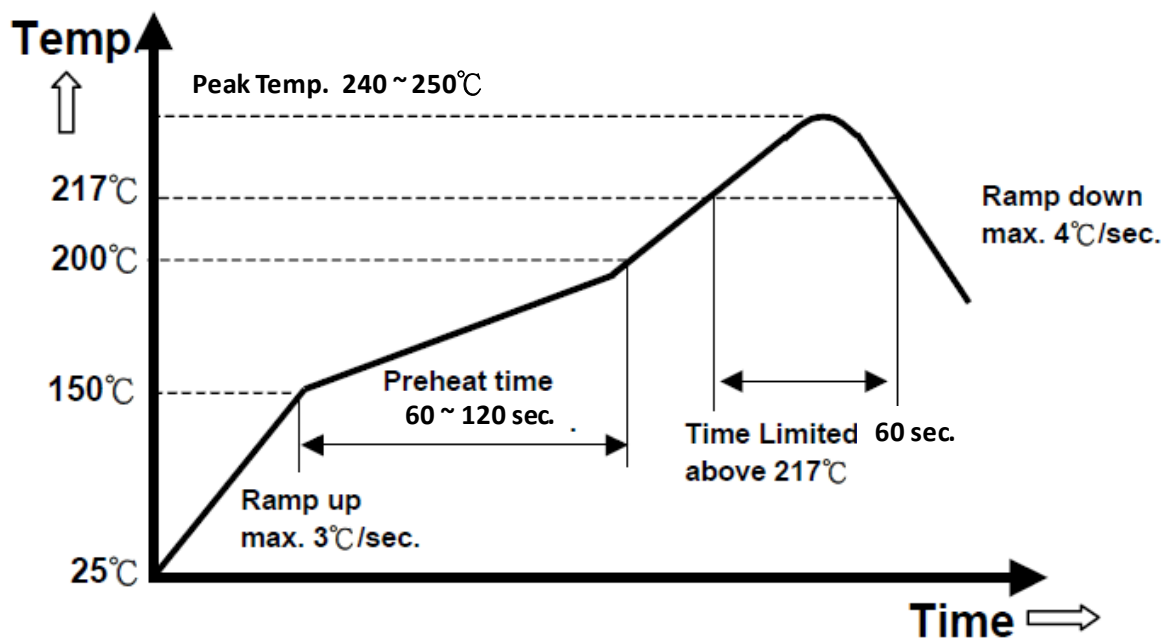

Figure 35. Case Temperature Sensing Point

REFLOW PARAMETERS:

Lead-free soldering process is a standard of electronic products production. Solder alloys like Sn/Ag, Sn/Ag/Cu and Sn/Ag/Bi are used extensively to replace the traditional Sn/Pb alloy. Sn/Ag/Cu alloy (SAC) is recommended for this power module process. In the SAC alloy series, SAC305 is a very popular solder alloy containing 3% Ag and 0.5% Cu and easy to obtain. Figure 36 shows an example of the reflow profile diagram. Typically, the profile has three stages. During the initial stage from room temperature to 150°C, the ramp rate of temperature should not be more than 3°C/sec. The soak zone then occurs from 150°C to 200°C and should last for 60 to 120 seconds. Finally, keep at over 217°C for 60 seconds limit to melt the solder and make the peak temperature at the range from 240°C to 250°C. It is noted that the time of peak temperature should depend on the mass of the PCB board. The reflow profile is usually supported by the solder vendor and one should adopt it for optimization according to various solder type and various manufacturers' formulae.

FIG.36 Recommendation Reflow Profile



PACKAGE OUTLINE DRAWING:

Unit: mm

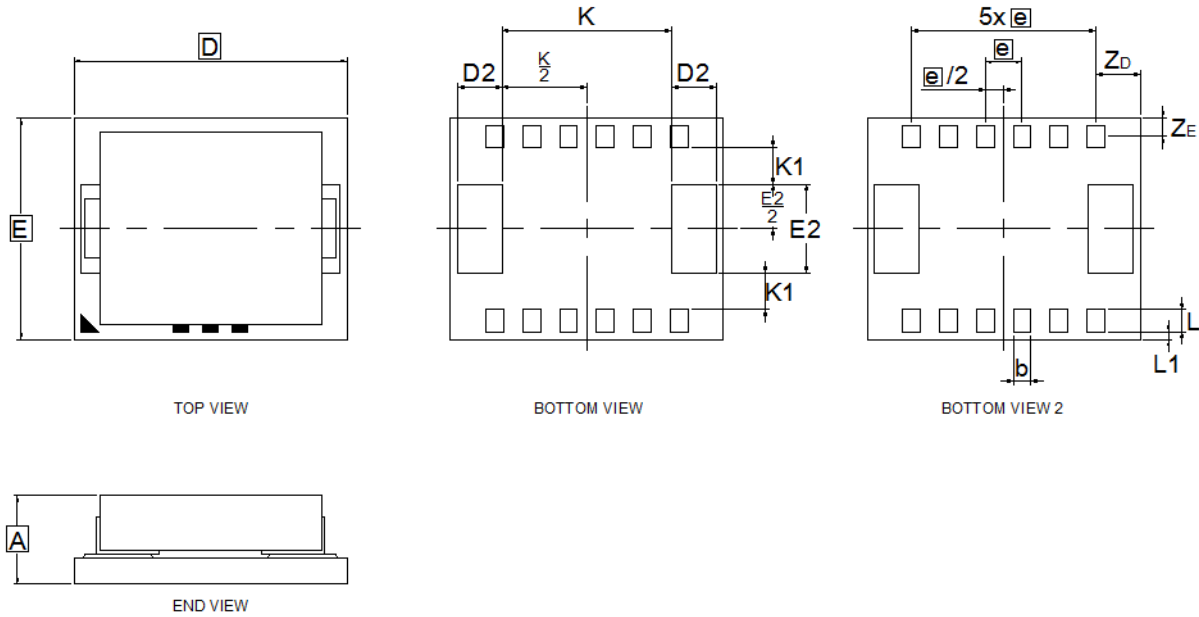

DIM	MILLIMETERS		
	MIN	NOM	MAX
A	1.00	1.10	1.20
b	0.14	0.24	0.34
D	3.6	3.7	3.8
D2	0.5	0.6	0.7
E	2.9	3.0	3.1
E2	1.1	1.2	1.3
e	0.40	0.50	0.60
K	2.2	2.3	2.4
K1	0.4	0.5	0.6
L	0.2	0.3	0.4
L1	0	0.1	0.2
Z _D	0.50	0.60	0.70
Z _E	0.15	0.25	0.35

LAND PATTERN REFERENCE:

Unit: mm

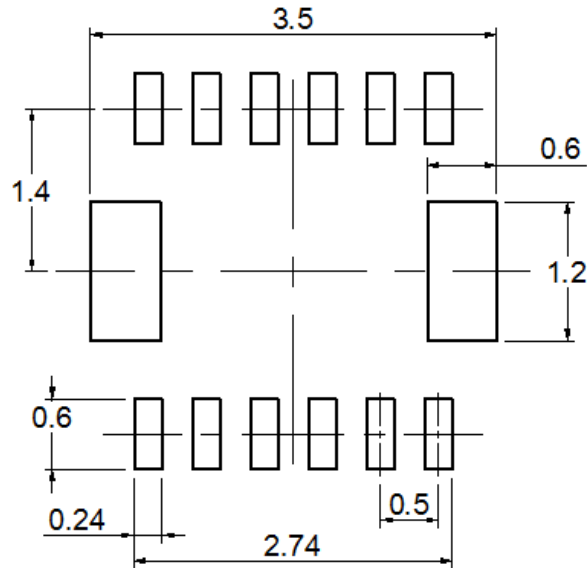

RECOMMENDED LAND PATTERN

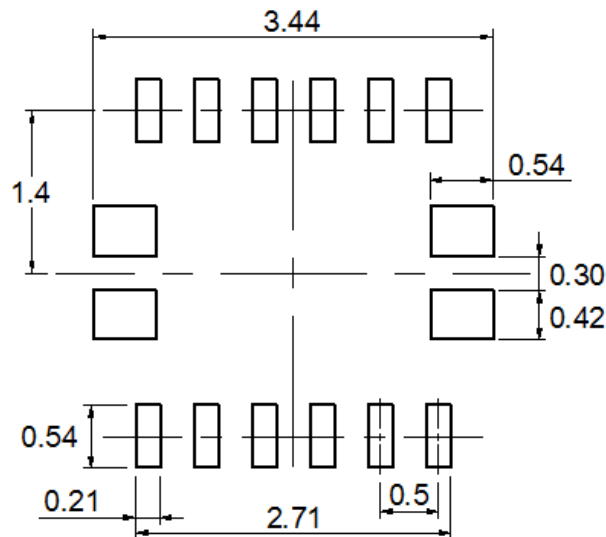

RECOMMENDED STENCIL PATTERN
BASED ON 0.1mm THICKNESS STENCIL

PACKING REFERENCE:

Unit: mm

Package In Tape Loading Orientation

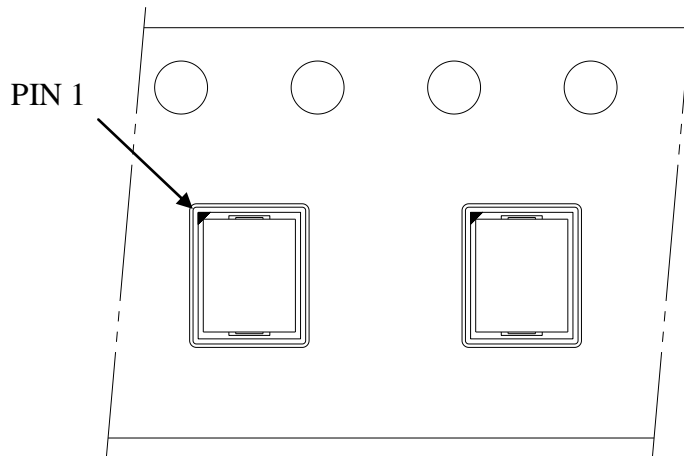

Tape Dimension

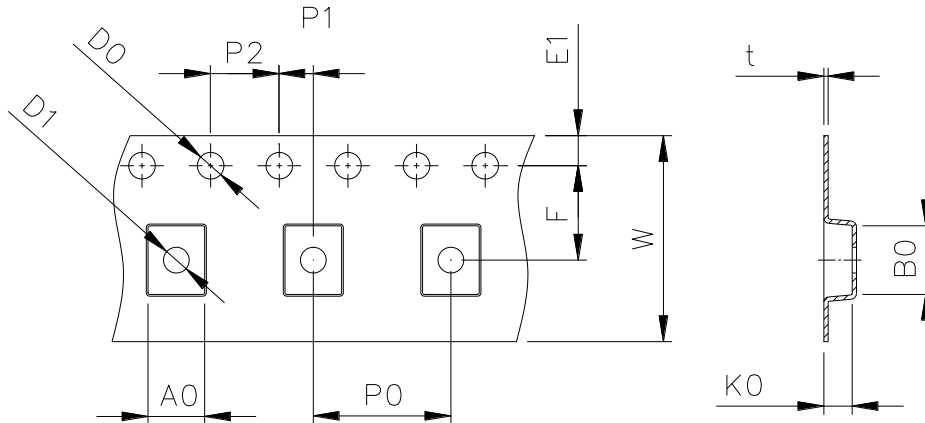

A0	3.3 ± 0.10	E1	1.75 ± 0.10
B0	4.0 ± 0.10	K0	1.65 ± 0.10
F	5.50 ± 0.05	P0	8.00 ± 0.10
W	12.0 ± 0.30	P1	2.00 ± 0.05
D0	$\phi 1.5 +0.10/-0.00$	P2	4.00 ± 0.10
D1	$\phi 1.50 \pm 0.10$	t	0.25 ± 0.1

PACKING REFERENCE: (Cont.)

Unit: mm

Reel Dimension

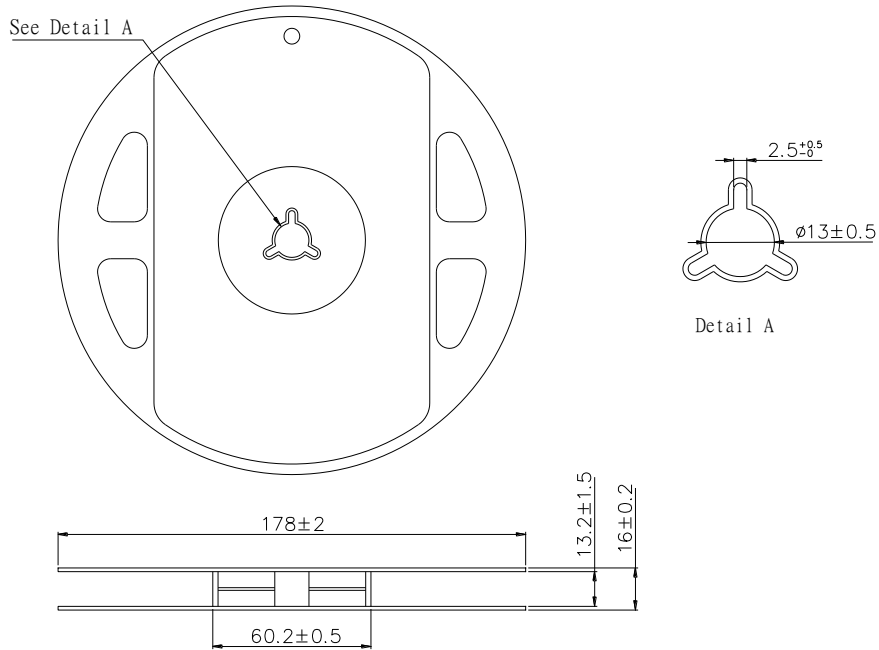

Peel Strength of Top Cover Tape

The peel speed shall be about 300mm/min.

The peel force of top cover tape shall be between 0.1N to 1.3N

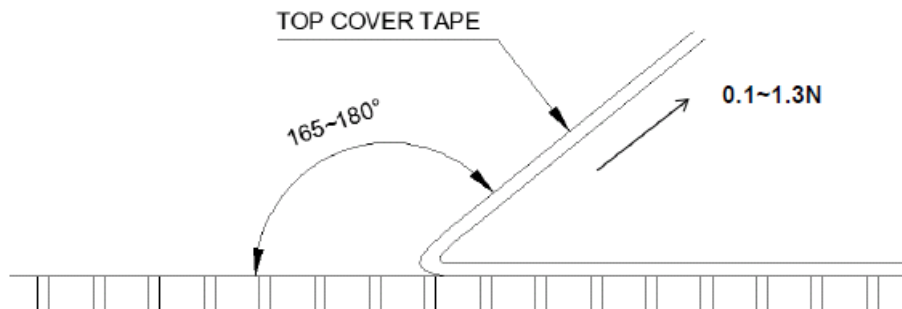

■ Precautions for use

To ensure user's safety, check specifications before using the product and always observe the following precautions for use.

- This product is intended for use in general electronics equipment (office equipment, communication equipment, measurement equipment). Do not use the product for medical equipment, nuclear equipment, trains, etc., whereby human life or property may be directly affected by damaged product. Consult with us for any use other than for such general electronics equipment.
- This product is not suitable for serial or parallel operation.
- Do not use connectors and sockets for mounting the product. Contact resistance may have an adverse effect on the performance. Use the soldering method for mounting on the printed circuit board.
- This equipment has a built-in over current protection circuit but avoid a prolonged short circuit which may lead to failure.
- This product may be damaged if used under nonstandard electrical conditions or nonstandard environmental conditions including temperature. Ensure use within the standards.
- Avoid using this product in a place that generates corrosive gas or is dusty.
- This product may be damaged by static electricity. Make sure that the workplace is guarded against static buildup and static electricity on operators by use of proper grounding.
- A fuse mechanism is not built in this product. Connect a fuse to +input line to guard against excessive input current under abnormal circumstances. Allow enough capacity for power supply for a fuse to blow.
- This product has no build-in function for over voltage protection. If over voltage occurs due to anomalies in the module, input voltage is output, as is, in the same mode, which may result in fumes and ignition. To prevent this from occurring, always add an over voltage protection circuit.
- This product does not come with a test report.

■ Warranty

The warranty term of the product is one year after shipment. Should the product become defective within the warranty period due to our design or workmanship, the product will be repaired free of charge or replaced.

However, this warranty does not cover products which have been subjected to unauthorized inner modifications, etc.

The scope of our warranty is limited to that of the said product.

■ Miscellaneous matters

Any doubt arising out of or in connection with these specifications shall be determined upon mutual consultation between the parties concerned.

■ Contact

If you have any further technical questions for this product, please contact us.

E-mail: info@bellnix.com

URL: <http://www.bellnix.com>