

Rev	AWO #	Description	Date	Appr
-	7426	RELEASED	01/11/07	

APPROVED: _____
 DATE: _____ TITLE: _____

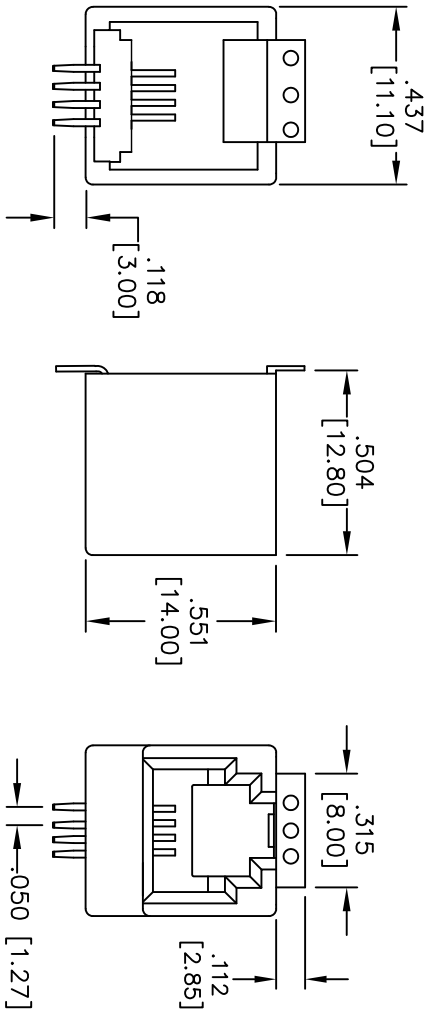

PACKAGED ON TAPE & REEL

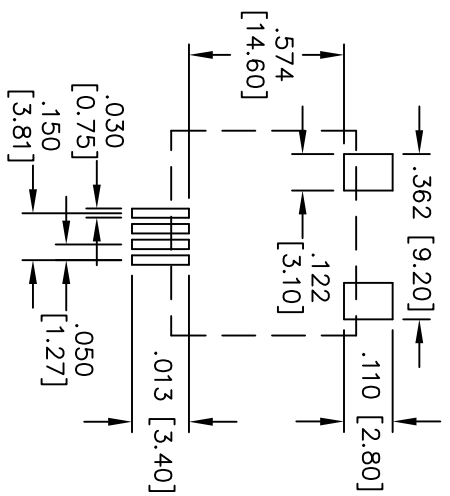

SPECIFICATIONS:

Material:
 Insulator: Hi-Temp Nylon, glass reinforced, rated UL 94V-0
 Insulator color: Black
 Contacts: Phosphor Bronze
Plating:
 .000005u" Gold over Nickel underplate on contact area, Tin over Copper underplate on SMT tails.

Electrical:
 Operating voltage: 150V AC max
 Current rating: 1.5 Amps max
 Contact resistance: 20m ohms max
 Insulation resistance: 500 Mohms min
 Dielectric withstanding voltage: 1000 VAC for 1 minute
Temperature Rating:
 Operating temperature: -40C to +125C

Packaging:
 Supplied on Tape and Reel
 Environmental:
 Lead free, RoHS compliant.
 Recommended soldering temp: 260° for 5 sec.



ADAM TECH

909 Rahway Avenue, Union, NJ 07083
 Phone: 908-687-5000 Fax: 908-687-5710

TITLE: TELEPHONE JACK, SMT, TOP ENTRY,
 4P4G, SURFACE MOUNT

UNLESS OTHERWISE SPECIFIED ALL DIMENSIONS ARE MM [INCHES] TOLERANCES: EXCEPT AS NOTED		INCHES		HOLE SIZE		DATE	
.X	± .10	ØX	± .10				
.XX	± .020	ØXXX	± .015				
.XXX	± .015	ØXXX	± .010				
DRAWN		BW		01/11/07			
CHECKED							
APPROVED							
SIZE	PART NO.	REF:	SCALE:	NTS	SHEET	1	OF 1
X	MTJ44HX1-T/R						