

# DELPHI SERIES



## FEATURES

- ♦ High Efficiency: 84% @ 1.5V/60A
- ♦ Size: 57.9 x 61.0 x 12.7mm  
(2.28" x 2.40" x 0.50")
- ♦ Standard footprint
- ♦ Industry standard pin out
- ♦ Fixed frequency operation
- ♦ Metal baseplate
- ♦ Input UVLO, Output OCP, OVP, OTP
- ♦ Basic insulation
- ♦ No minimum load required
- ♦ 2:1 Input voltage range
- ♦ ISO 9001, TL 9000, ISO 14001, QS9000, OHSAS18001 certified manufacturing facility
- ♦ UL/cUL 60950 (US & Canada) Recognized, and TUV (EN60950) Certified
- ♦ CE mark meets 73/23/EEC and 93/68/EEC directives

## Delphi Series H48SL, 200W Half Brick Family DC/DC Power Modules: 48V in, 1.5V/60A out

The Delphi Series H48SL Half Brick, 48V input, single output, isolated DC/DC converters are the latest offering from a world leader in power systems technology and manufacturing — Delta Electronics, Inc. This product family provides up to 200 watts of power (3.3V and above) or 60A of output current in an industry standard footprint. With creative design technology and optimization of component placement, these converters possess outstanding electrical and thermal performance, as well as extremely high reliability under highly stressful operating conditions. All models are fully protected from abnormal input/output voltage, current, and temperature conditions. The Delphi Series converters meet all safety requirements with basic insulation.

## OPTIONS

- ♦ Positive Remote On/Off logic
- ♦ Negative trim
- ♦ Short pin lengths

## APPLICATIONS

- ♦ Telecom/Datacom
- ♦ Wireless Networks
- ♦ Optical Network Equipment
- ♦ Server and Data Storage
- ♦ Industrial/Test Equipment

DATASHEET

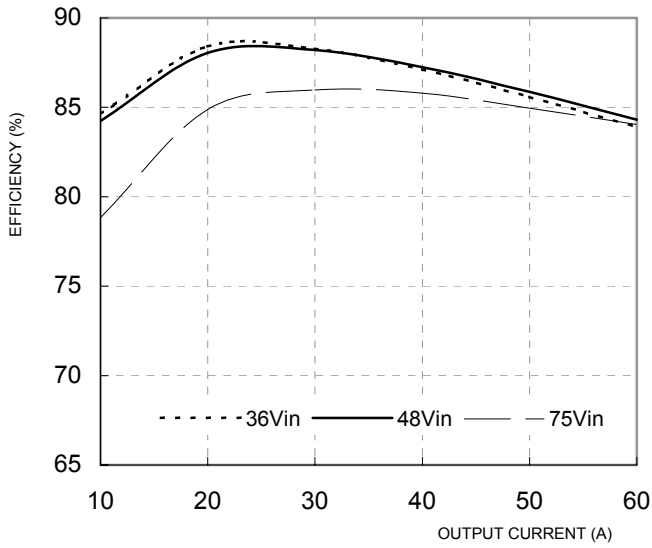
DS\_H48SL1R560\_10302006

# TECHNICAL SPECIFICATIONS

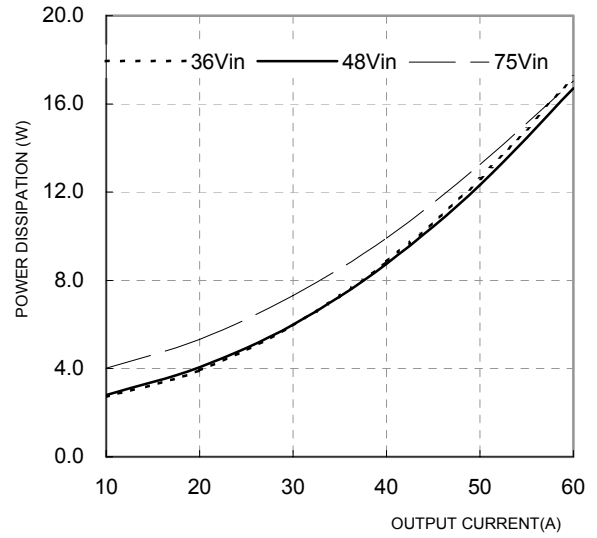
(T<sub>A</sub>=25°C, airflow rate=300 LFM, V<sub>in</sub>=48Vdc, nominal V<sub>out</sub> unless otherwise noted)

PARAMETER	NOTES and CONDITIONS	H48SL1R560 (Standard)			
		Min.	Typ.	Max.	Units
<b>ABSOLUTE MAXIMUM RATINGS</b>					
<b>Input Voltage</b>					
Continuous				80	Vdc
Transient (100ms)	100ms			100	Vdc
Operating Case Temperature	T <sub>c</sub>	-40		+100	°C
Storage Temperature		-55		+125	°C
Input/Output Isolation Voltage	1 minute	1500			Vdc
<b>INPUT CHARACTERISTICS</b>					
Operating Input Voltage		36	48	75	Vdc
<b>Input Under-Voltage Lockout</b>					
Turn-On Voltage Threshold		33	34	35	Vdc
Turn-Off Voltage Threshold		31	32	33	Vdc
Lockout Hysteresis Voltage		1	2	3	Vdc
Maximum Input Current	100% Load, 36Vin			3.6	A
No-Load Input Current			60	150	mA
Off Converter Input Current			3	10	mA
Inrush Current(I <sup>2</sup> t)			0.03		A <sup>2</sup> s
Input Reflected-Ripple Current	P-P thru 12μH inductor, 5Hz to 20MHz		25		mA
Input Voltage Ripple Rejection	120 Hz		65		dB
<b>OUTPUT CHARACTERISTICS</b>					
Output Voltage Set Point	V <sub>in</sub> =48V, I <sub>o</sub> =I <sub>o,max</sub> , T <sub>c</sub> =25°C	1.47	1.5	1.53	Vdc
<b>Output Voltage Regulation</b>					
Over Load	I <sub>o</sub> =I <sub>o,min</sub> to I <sub>o,max</sub>		±2	±5	mV
Over Line	V <sub>in</sub> =36V to 75V		±2	±5	mV
Over Temperature	T <sub>c</sub> =-40°C to 100°C		±15	±50	mV
Total Output Voltage Range	over sample load, line and temperature	1.43		1.57	V
<b>Output Voltage Ripple and Noise</b>					
	5Hz to 20MHz bandwidth				
Peak-to-Peak	Full Load, 1μF ceramic, 10μF tantalum		75	150	mV
RMS	Full Load, 1μF ceramic, 10μF tantalum		25	40	mV
<b>Operating Output Current Range</b>					
Output DC Current-Limit Inception	Output Voltage 10% Low	110		150	%
<b>DYNAMIC CHARACTERISTICS</b>					
<b>Output Voltage Current Transient</b>					
	48V, 10μF Tan & 1μF Ceramic load cap, 0.1A/μs				
Positive Step Change in Output Current	50% I <sub>o,max</sub> to 75% I <sub>o,max</sub>		80		mV
Negative Step Change in Output Current	75% I <sub>o,max</sub> to 50% I <sub>o,max</sub>		80		mV
Settling Time (within 1% V <sub>out</sub> nominal)			100		us
<b>Turn-On Transient</b>					
Start-Up Time, From On/Off Control			10	20	ms
Start-Up Time, From Input			10	20	ms
Maximum Output Capacitance	Full load; 5% overshoot of V <sub>out</sub> at startup			20000	μF
<b>EFFICIENCY</b>					
100% Load			84		%
60% Load			87		%
<b>ISOLATION CHARACTERISTICS</b>					
Input to Output		1500			Vdc
Input to Case		1500			Vdc
Output to Case		500			Vdc
Isolation Resistance		10			MΩ
Isolation Capacitance			1300		pF
<b>FEATURE CHARACTERISTICS</b>					
<b>Switching Frequency</b>					
ON/OFF Control, Negative Remote On/Off logic			180		kHz
Logic Low (Module On)	V <sub>on/off</sub> at I <sub>on/off</sub> =1.0mA	0		0.8	V
Logic High (Module Off)	V <sub>on/off</sub> at I <sub>on/off</sub> =0.0 μA			15	V
ON/OFF Control, Positive Remote On/Off logic					
Logic Low (Module Off)	V <sub>on/off</sub> at I <sub>on/off</sub> =1.0mA	0		0.4	V
Logic High (Module On)	V <sub>on/off</sub> at I <sub>on/off</sub> =0.0 μA			15	V
ON/OFF Current (for Both Remote on/off logic)	I <sub>on/off</sub> at V <sub>on/off</sub> =0.0V			1	mA
Leakage Current (for Both Remote on/off logic)	Logic High, V <sub>on/off</sub> =15V			50	uA
Output Voltage Trim Range	Across Pins 9 & 5, P <sub>out</sub> ≤ max rated power	-20		+10	%
Output Voltage Remote Sense Range	P <sub>out</sub> ≤ max rated power			10	%
Output Over-Voltage Protection	Over full temp range; % of nominal V <sub>out</sub>	115	122	130	%
<b>GENERAL SPECIFICATIONS</b>					
MTBF	I <sub>o</sub> =80% of I <sub>o,max</sub> ; T <sub>a</sub> =25°C		2.23		M hours
Weight			85		grams
Over-Temperature Shutdown	Average PCB Temperature		110		°C

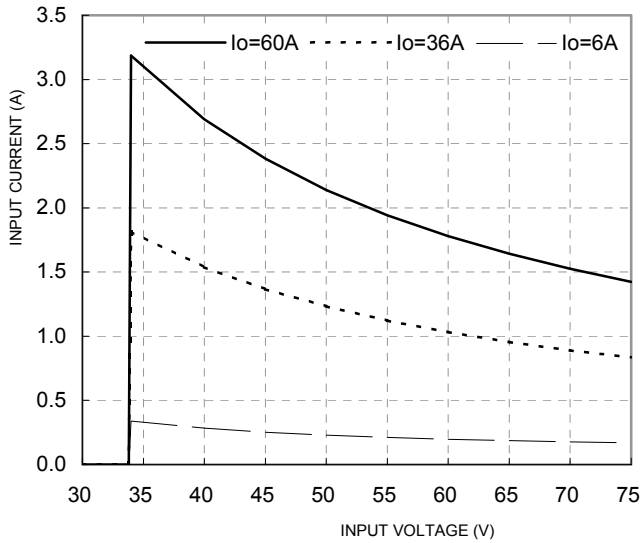
# ELECTRICAL CHARACTERISTICS CURVES



**Figure 1:** Efficiency vs. load current for minimum, nominal, and maximum input voltage at 25°C.



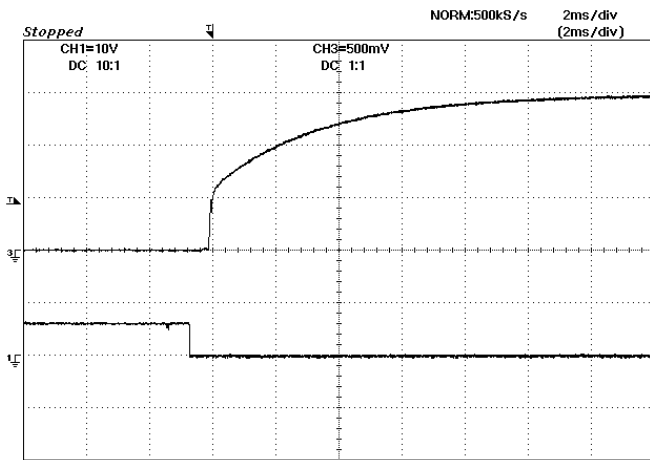
**Figure 2:** Power dissipation vs. load current for minimum, nominal, and maximum input voltage at 25°C.



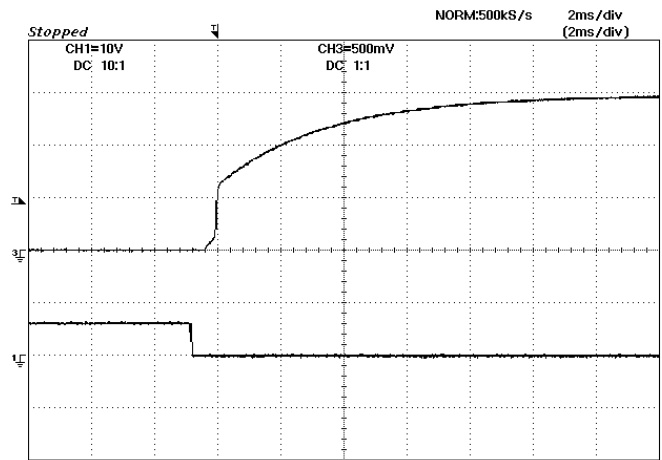
**Figure 3:** Typical input characteristics at room temperature

# ELECTRICAL CHARACTERISTICS CURVES

## For Negative Remote On/Off Logic

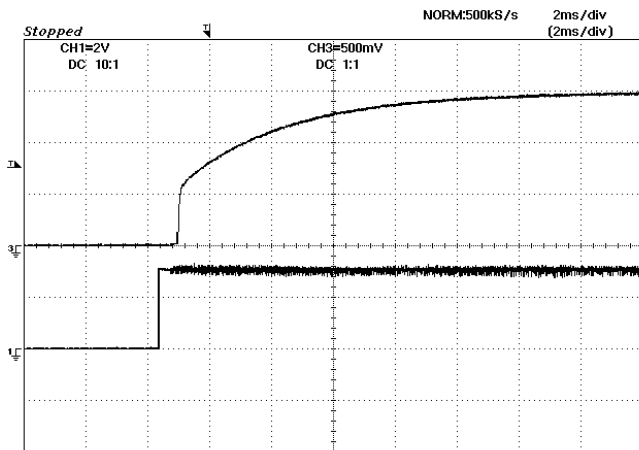


**Figure 4:** Turn-on transient at full rated load current (resistive load) (2 ms/div). Top Trace: Vout; 500mV/div; Bottom Trace: ON/OFF input: 10V/div

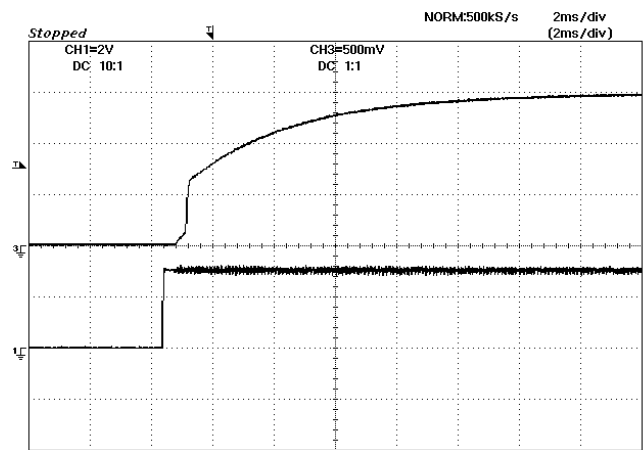


**Figure 5:** Turn-on transient at zero load current (2 ms/div). Top Trace: Vout; 500mV/div; Bottom Trace: ON/OFF input: 10V/div

## For Positive Remote On/Off Logic

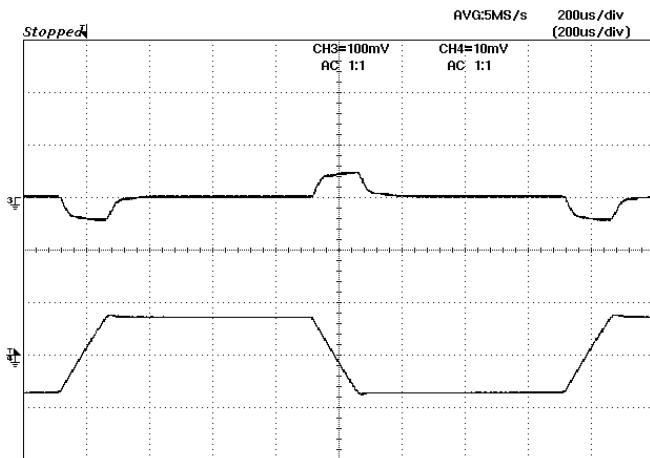


**Figure 6:** Turn-on transient at full rated load current (resistive load) (2 ms/div). Top Trace: Vout; 500mV/div; Bottom Trace: ON/OFF input: 2V/div

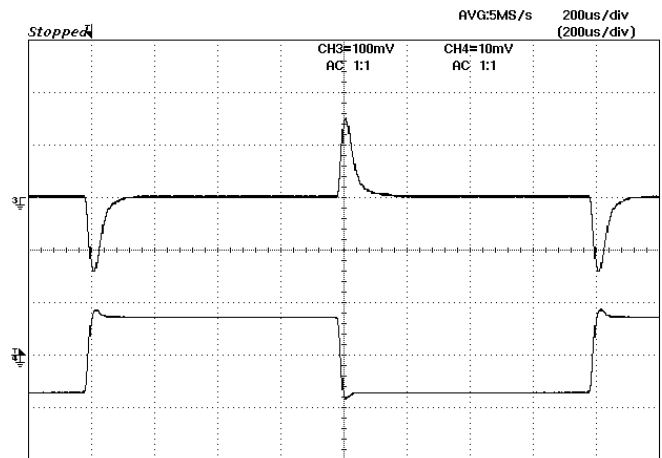


**Figure 7:** Turn-on transient at zero load current (2 ms/div). Top Trace: Vout; 500mV/div; Bottom Trace: ON/OFF input: 2V/div

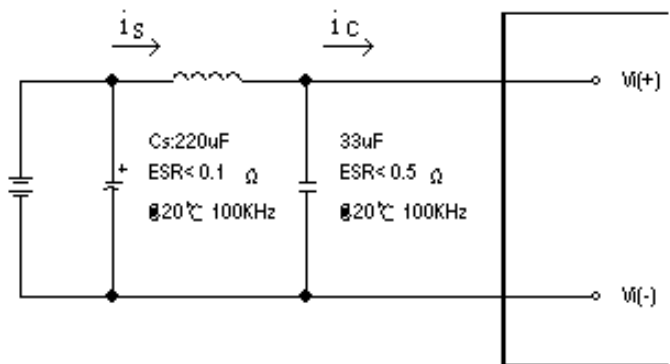
# ELECTRICAL CHARACTERISTICS CURVES



**Figure 8:** Output voltage response to step-change in load current (75%-50%-75% of  $I_o$ , max;  $di/dt = 0.1A/\mu s$ ). Load cap:  $10\mu F$ , tantalum capacitor and  $1\mu F$  ceramic capacitor. Top Trace:  $V_{out}$  (100mV/div), Bottom Trace:  $I_{out}$  (10A/div). Scope measurement should be made using a BNC cable (length shorter than 20 inches). Position the load between 51 mm to 76 mm (2 inches to 3 inches) from the module.



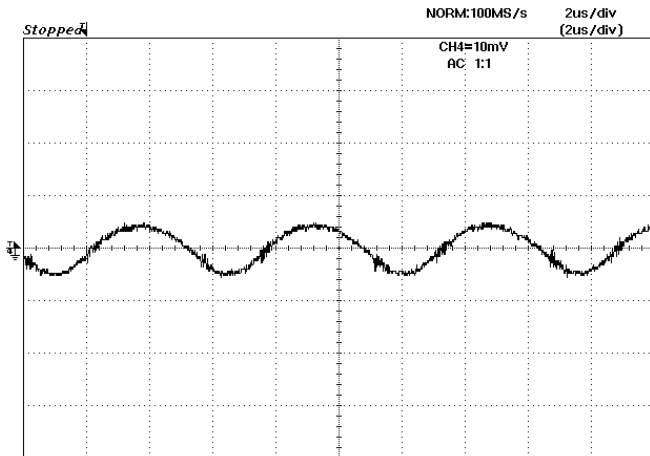
**Figure 9:** Output voltage response to step-change in load current (75%-50%-75% of  $I_o$ , max;  $di/dt = 2.5A/\mu s$ ). Load cap:  $470\mu F$ ,  $35m\Omega$  ESR solid electrolytic capacitor and  $1\mu F$  ceramic capacitor. Top Trace:  $V_{out}$  (100mV/div), Bottom Trace:  $I_{out}$  (10A/div). Scope measurement should be made using a BNC cable (length shorter than 20 inches). Position the load between 51 mm to 76 mm (2 inches to 3 inches) from the module.



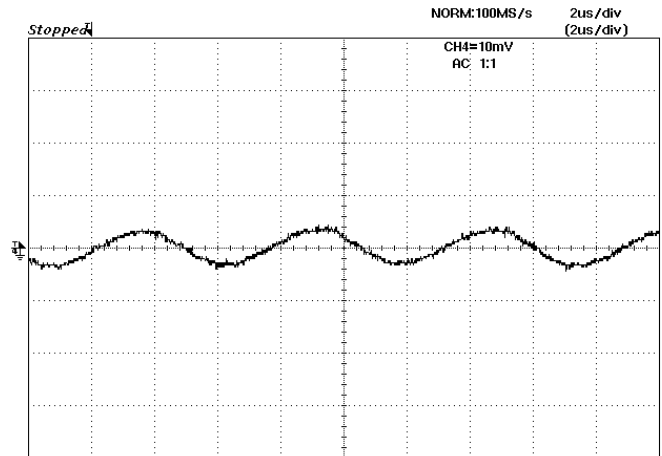
**Figure 10:** Test set-up diagram showing measurement points for Input Terminal Ripple Current and Input Reflected Ripple Current.

Note: Measured input reflected-ripple current with a simulated source Inductance ( $L_{TEST}$ ) of  $12\mu H$ . Capacitor  $C_s$  offset possible battery impedance. Measure current as shown above.

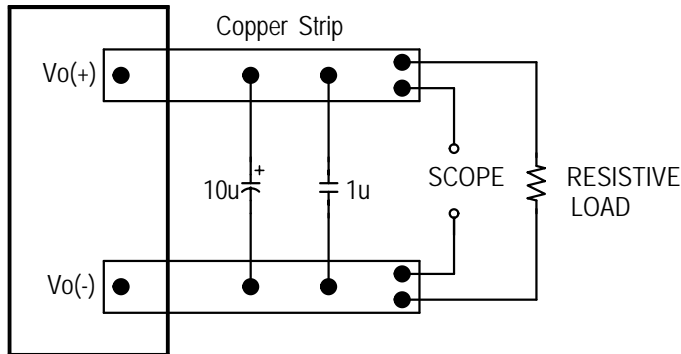
# ELECTRICAL CHARACTERISTICS CURVES



**Figure 11:** Input Terminal Ripple Current,  $i_c$ , at full rated output current and nominal input voltage with  $12\mu\text{H}$  source impedance and  $33\mu\text{F}$  electrolytic capacitor (1A/div).

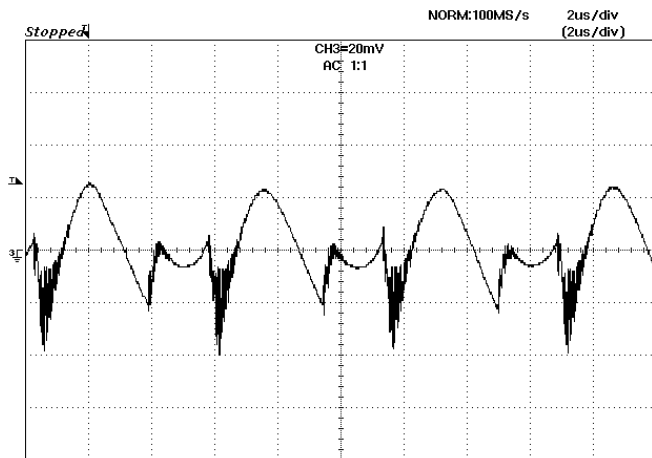


**Figure 12:** Input reflected ripple current,  $i_s$ , through a  $12\mu\text{H}$  source inductor at nominal input voltage and rated load current (20 mA/div).

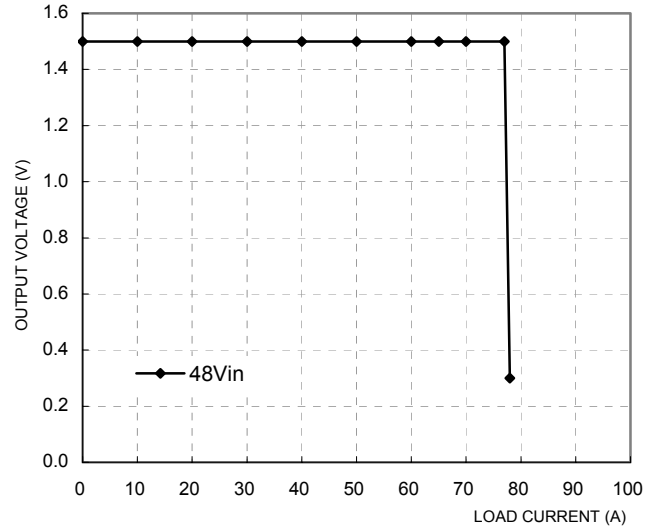


**Figure 13:** Output voltage noise and ripple measurement test setup

## ELECTRICAL CHARACTERISTICS CURVES

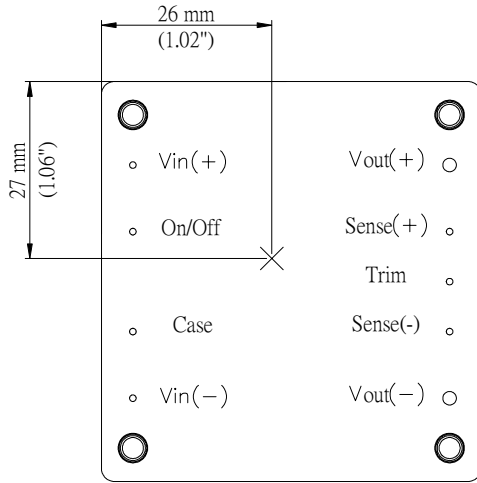


**Figure 14:** Output voltage ripple at nominal input voltage and rated load current (20 mV/div). Load capacitance: 1 μF ceramic capacitor and 10 μF tantalum capacitor. Bandwidth: 20 MHz. Scope measurement should be made using a BNC cable (length shorter than 20 inches). Position the load between 51 mm to 76 mm (2 inches to 3 inches) from the module.

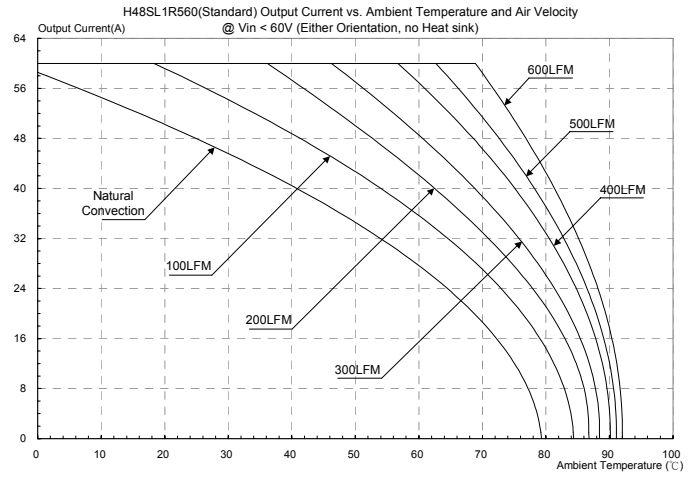


**Figure 15:** Output voltage vs. load current showing typical current limit curves and converter shutdown points.

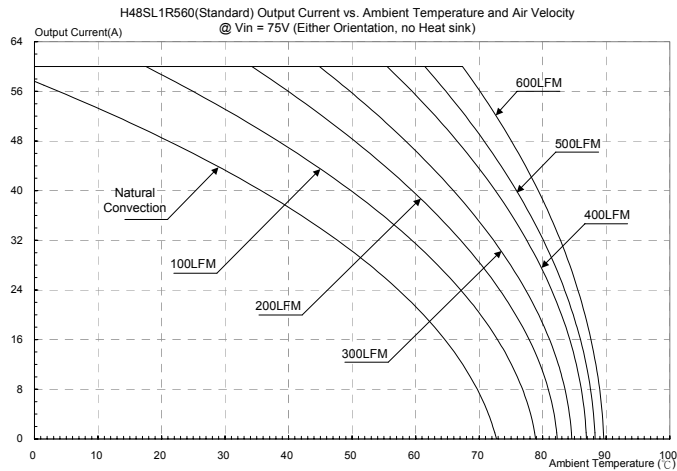
# THERMAL CURVES: NO HEATSINK, EITHER ORIENTATION



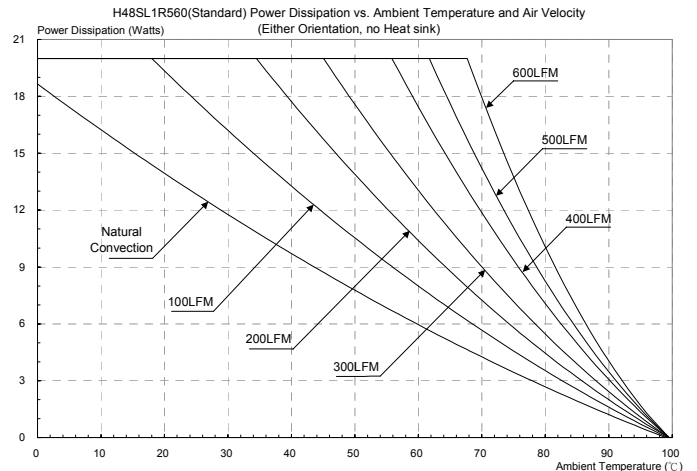
**Figure 16:** Case temperature measurement location. Pin locations are for reference only.



**Figure 17:** Output current vs. ambient temperature and air velocity ( $V_{in} < 60V$ )



**Figure 18:** Output current vs. ambient temperature and air velocity ( $V_{in} = 75V$ )



**Figure 19:** Power dissipation vs. ambient temperature and air velocity

## DESIGN CONSIDERATIONS

### Input Source Impedance

The impedance of the input source connecting to the DC/DC power modules will interact with the modules and affect the stability. A low ac-impedance input source is recommended. If the source inductance is more than a few  $\mu\text{H}$ , we advise adding a 10 to 100  $\mu\text{F}$  electrolytic capacitor ( $\text{ESR} < 0.7 \Omega$  at 100 kHz) mounted close to the input of the module to improve the stability.

### Layout and EMC Considerations

Delta's DC/DC power modules are designed to operate in a wide variety of systems and applications. For design assistance with EMC compliance and related PWB layout issues, please contact Delta's technical support team. An external input filter module is available for easier EMC compliance design. Application notes to assist designers in addressing these issues are pending release.

### Safety Considerations

The power module must be installed in compliance with the spacing and separation requirements of the end-user's safety agency standard, i.e., UL60950, CAN/CSA-C22.2 No. 60950-00 and EN60950:2000 and IEC60950-1999, if the system in which the power module is to be used must meet safety agency requirements.

Basic insulation based on 75 Vdc input is provided between the input and output of the module for the purpose of applying insulation requirements when the input to this DC-to-DC converter is identified as TNV-2 or SELV. An additional evaluation is needed if the source is other than TNV-2 or SELV.

When the input source is 60 Vdc or below, the power module meets SELV (safety extra-low voltage) requirements. If the input source is a hazardous voltage which is greater than 60 Vdc and less than or equal to 75 Vdc, for the module's output to meet SELV requirements, all of the following must be met:

- The input source must be insulated from the ac mains by reinforced or double insulation.
- The input terminals of the module are not operator accessible.
- If the metal baseplate is grounded, one  $V_i$  pin and one  $V_o$  pin shall also be grounded.
- A SELV reliability test is conducted on the system where the module is used, in combination with the module, to ensure that under a single fault, hazardous voltage does not appear at the module's output.

When installed into a Class II equipment (without grounding), spacing consideration should be given to the end-use installation, as the spacing between the module and mounting surface have not been evaluated.

The power module has extra-low voltage (ELV) outputs when all inputs are ELV.

This power module is not internally fused. To achieve optimum safety and system protection, an input line fuse is highly recommended. The safety agencies require a normal-blow fuse with 20A maximum rating to be installed in the ungrounded lead. A lower rated fuse can be used based on the maximum inrush transient energy and maximum input current.

### Soldering and Cleaning Considerations

Post solder cleaning is usually the final board assembly process before the board or system undergoes electrical testing. Inadequate cleaning and/or drying may lower the reliability of a power module and severely affect the finished circuit board assembly test. Adequate cleaning and/or drying is especially important for un-encapsulated and/or open frame type power modules. For assistance on appropriate soldering and cleaning procedures, please contact Delta's technical support team.

## FEATURES DESCRIPTIONS

### Over-Current Protection

The modules include an internal output over-current protection circuit, which will endure current limiting for an unlimited duration during output overload. If the output current exceeds the OCP set point, the modules will automatically shut down (hiccup mode).

The modules will try to restart after shutdown. If the overload condition still exists, the module will shut down again. This restart trial will continue until the overload condition is corrected.

### Over-Voltage Protection

The modules include an internal output over-voltage protection circuit, which monitors the voltage on the output terminals. If this voltage exceeds the over-voltage set point, the module will shut down and latch off. The over-voltage latch is reset by either cycling the input power or by toggling the on/off signal for one second.

### Over-Temperature Protection

The over-temperature protection consists of circuitry that provides protection from thermal damage. If the temperature exceeds the over-temperature threshold the module will shut down.

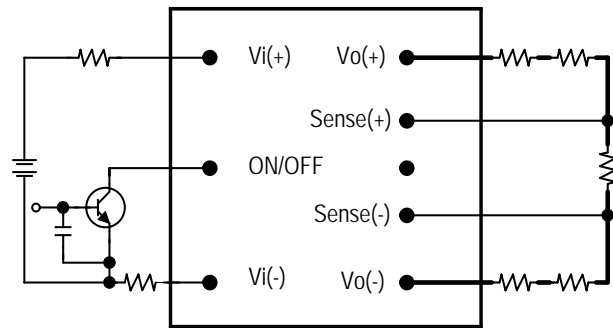
The module will try to restart after shutdown. If the over-temperature condition still exists during restart, the module will shut down again. This restart trial will continue until the temperature is within specification.

### Remote On/Off

The remote on/off feature on the module can be either negative or positive logic. Negative logic turns the module on during a logic low and off during a logic high. Positive logic turns the modules on during a logic high and off during a logic low.

Remote on/off can be controlled by an external switch between the on/off terminal and the Vi(-) terminal. The switch may be an open collector or open drain.

For negative logic if the remote on/off feature is not used, please short the on/off pin to Vi(-). For positive logic if the remote on/off feature is not used, please leave the on/off pin floating.



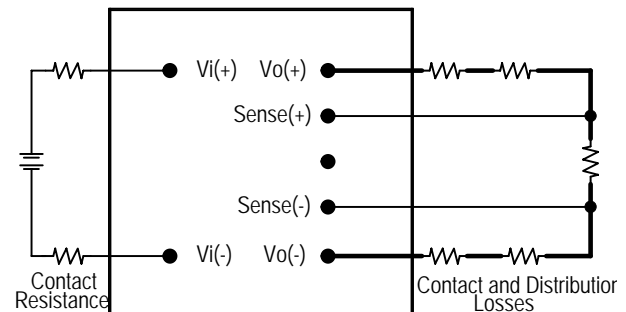
**Figure 20:** Remote on/off implementation

### Remote Sense

Remote sense compensates for voltage drops on the output by sensing the actual output voltage at the point of load. The voltage between the remote sense pins and the output terminals must not exceed the output voltage sense range given here:

$$[Vo(+) - Vo(-)] - [SENSE(+) - SENSE(-)] \leq 10\% \times V_{out}$$

This limit includes any increase in voltage due to remote sense compensation and output voltage set point adjustment (trim).



**Figure 21:** Effective circuit configuration for remote sense operation

If the remote sense feature is not used to regulate the output at the point of load, please connect SENSE(+) to Vo(+) and SENSE(-) to Vo(-) at the module.

The output voltage may be increased by both the remote sense and the trim; however, the maximum increase is the larger of either the remote sense or the trim, not the sum of both.

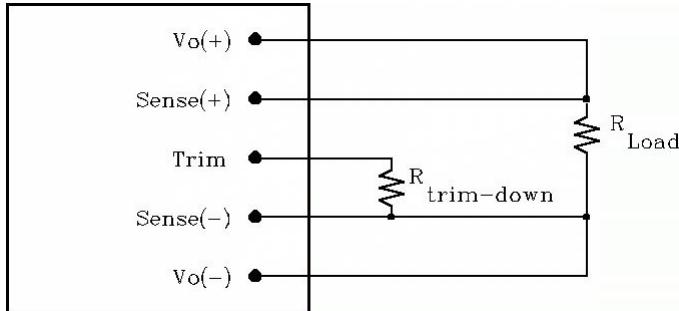
When using remote sense and trim, the output voltage of the module is usually increased, which increases the power output of the module with the same output current.

Care should be taken to ensure that the maximum output power does not exceed the maximum rated power.

## FEATURES DESCRIPTIONS (CON.)

### Output Voltage Adjustment (TRIM)

To increase or decrease the output voltage set point, connect an external resistor between the TRIM pin and either the SENSE(+) or SENSE(-). The TRIM pin should be left open if this feature is not used.



**Figure 22:** Circuit configuration for trim-down (decrease output voltage)

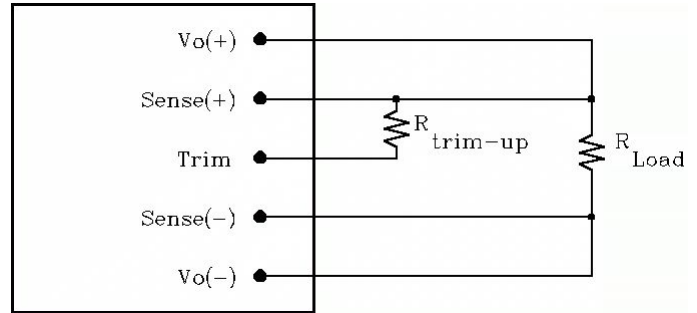
If the external resistor is connected between the TRIM and SENSE (-) pins, the output voltage set point decreases.(Fig. 22) The external resistor value required to obtain a percentage of output voltage change  $\Delta\%$  is defined as:

$$R_{\text{trim down}} = \left( \frac{100}{\Delta\%} - 2 \right) \text{K}\Omega$$

Ex. When Trim-down -20%(1.5V×0.8=1.2V)

$$V_o := 1.5 \text{ V} \quad \Delta := 20$$

$$\frac{100}{\Delta} - 2 = 3 \text{ K}\Omega$$



**Figure 23:** Circuit configuration for trim-up (increase output voltage)

If the external resistor is connected between the TRIM and SENSE (+) the output voltage set point increases (Fig. 23). The external resistor value required to obtain a percentage output voltage change  $\Delta\%$  is defined as:

$$R_{\text{trim up}} = \left[ \frac{V_o \cdot (100 + \Delta\%)}{1.225 \Delta\%} - \frac{100 + 2\Delta\%}{\Delta\%} \right] \text{K}\Omega$$

Ex. When Trim-up +10%(1.5V×1.1=1.65V)

$$V_o := 1.5 \text{ V} \quad \Delta := 10$$

$$\frac{V_o \cdot (100 + \Delta)}{1.225 \cdot \Delta} - \frac{100 + 2 \cdot \Delta}{\Delta} = 1.469 \text{ K}\Omega$$

The output voltage can be increased by both the remote sense and the trim, however the maximum increase is the larger of either the remote sense or the trim, not the sum of both.

When using remote sense and trim, the output voltage of the module is usually increased, which increases the power output of the module with the same output current.

Care should be taken to ensure that the maximum output power of the module remains at or below the maximum rated power.

## Thermal Considerations

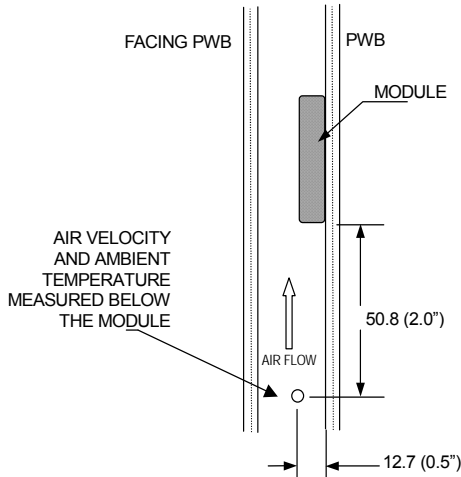
Thermal management is an important part of the system design. To ensure proper, reliable operation, sufficient cooling of the power module is needed over the entire temperature range of the module. Convection cooling is usually the dominant mode of heat transfer.

Hence, the choice of equipment to characterize the thermal performance of the power module is a wind tunnel.

### Thermal Testing Setup

Delta's DC/DC power modules are characterized in heated vertical wind tunnels that simulate the thermal environments encountered in most electronics equipment. This type of equipment commonly uses vertically mounted circuit cards in cabinet racks in which the power modules are mounted.

The following figure shows the wind tunnel characterization setup. The power module is mounted on a test PWB and is vertically positioned within the wind tunnel. The space between the neighboring PWB and the top of the power module is constantly kept at 6.35mm (0.25").



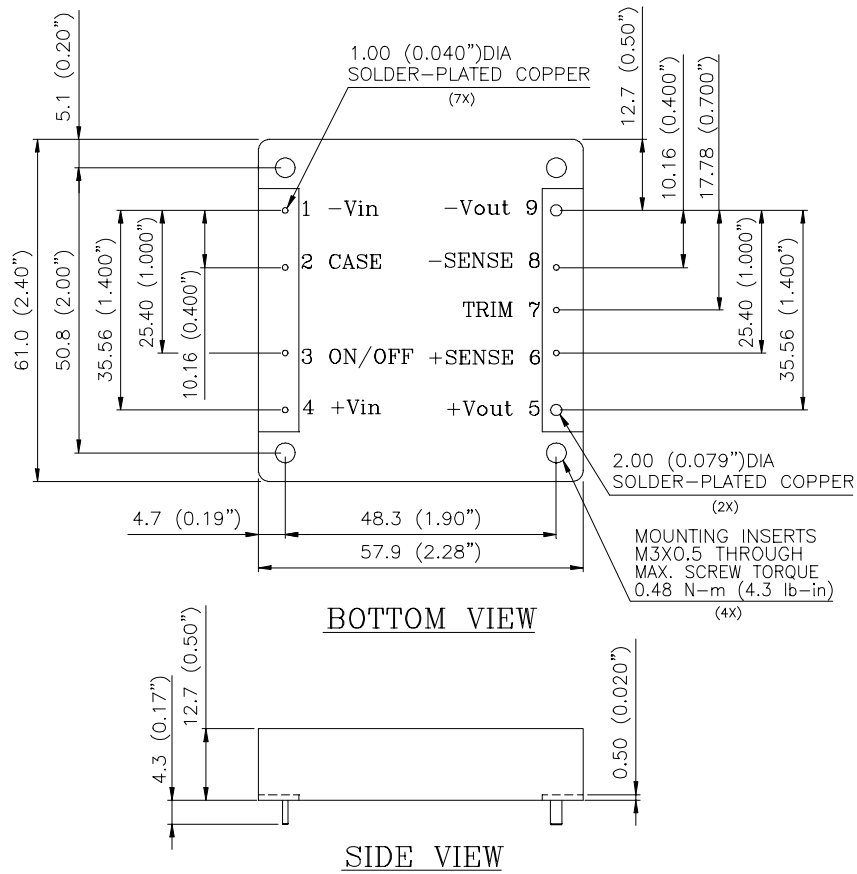
Note: Wind Tunnel Test Setup Figure Dimensions are in millimeters and (Inches)

Figure 24: Wind tunnel test setup

### Thermal Derating

Heat may be removed by increasing airflow over the module. The module's maximum case temperature is +100°C. To enhance system reliability, the power module should always be operated below the maximum operating temperature. If the temperature exceeds the maximum module temperature, reliability of the unit may be affected.

# MECHANICAL DRAWING



## NOTES:

DIMENSIONS ARE IN MILLIMETERS AND (INCHES)

TOLERANCES: X.Xmm±0.5mm(X.XX in.±0.02 in.)

X.XXmm±0.25mm(X.XXX in.±0.010 in.)

<u>Pin No.</u>	<u>Name</u>	<u>Function</u>
1	-Vin	Negative input voltage
2	Case	Case ground
3	ON/OFF	Remote ON/OFF
4	+Vin	Positive input voltage
5	+Vout	Positive output voltage
6	+SENSE	Positive remote sense
7	TRIM	Output voltage trim
8	-SENSE	Negative remote sense
9	-Vout	Negative output voltage

## Pin Specification:

Pins 1-4, 6-8                    1.00mm (0.040") diameter  
Pins 5 & 9                        2.00mm (0.079") diameter

All pins are copper with Tin plating.

## PART NUMBERING SYSTEM

H	48	S	L	1R5	60	N	R	F	A
Form Factor	Input Voltage	Number of Outputs	Product Series	Output Voltage	Output Current	ON/OFF Logic	Pin Length		Option Code
H – Half-Brick	48V	S - Single	L - IMS, positive trim	1R5 - 1.5V	60 - 60A	N - Negative P - Positive	R - 0.170" N - 0.145" K - 0.110"	F- RoHS 6/6 Lead Free)	A - Standard Functions

## MODEL LIST

MODEL NAME	INPUT		OUTPUT		EFF @ 100% LOAD
H48SL1R560NRFA	36V~75V	3.6A	1.5V	60A	84%
H48SL1R860NRFA	36V~75V	4.3A	1.8V	60A	85%
H48SL2R560NRFA	36V~75V	5.7A	2.5V	60A	88%
H48SL3R360NRFA	36V~75V	7.4A	3.3V	60A	89%
H48SL05040NRFA	36V~75V	7.4A	5V	40A	90.5%
H48SL12020NRFA	36V~75V	8.7A	12V	20A	91%

Default remote on/off logic is negative and pin length is 0.170"

For different remote on/off logic and pin length, please refer to part numbering system above or contact your local sales office.

### CONTACT: [www.delta.com.tw/dcdc](http://www.delta.com.tw/dcdc)

#### USA:

Telephone:  
East Coast: (888) 335 8201  
West Coast: (888) 335 8208  
Fax: (978) 656 3964  
Email: [DCDC@delta-corp.com](mailto:DCDC@delta-corp.com)

#### Europe:

Telephone: +41 31 998 53 11  
Fax: +41 31 998 53 53  
Email: [DCDC@delta-es.tw](mailto:DCDC@delta-es.tw)

#### Asia & the rest of world:

Telephone: +886 3 4526107 x6220  
Fax: +886 3 4513485  
Email: [DCDC@delta.com.tw](mailto:DCDC@delta.com.tw)

## WARRANTY

Delta offers a two (2) year limited warranty. Complete warranty information is listed on our web site or is available upon request from Delta.

Information furnished by Delta is believed to be accurate and reliable. However, no responsibility is assumed by Delta for its use, nor for any infringements of patents or other rights of third parties, which may result from its use. No license is granted by implication or otherwise under any patent or patent rights of Delta. Delta reserves the right to revise these specifications at any time, without notice.