

DATA SHEET

GENERAL PURPOSE CHIP RESISTORS

RC0201
5%, 1%, 0.5%
RoHS compliant & Halogen free



SCOPE

This specification describes RC0201 series chip resistors with lead-free terminations made by thick film process.

APPLICATIONS

- All general purpose application

FEATURES

- Halogen Free Epoxy
- RoHS compliant
 - Products with lead free terminations meet RoHS requirements.
 - Pb-glass contained in electrodes, resistor element and glass are exempted by RoHS.
- Reduce environmentally hazardous wastes
- High component and equipment reliability
- Save of PCB space
- None forbidden-materials used in products/production.

ORDERING INFORMATION - GLOBAL PART NUMBER & I2NC

Both part numbers are identified by the series, size, tolerance, packing type, temperature coefficient, taping reel and resistance value.

YAGEO BRAND ordering code

GLOBAL PART NUMBER (PREFERRED)

RC0201 **X** **R** - **XX** **XXXX** **L**
 (1) (2) (3) (4) (5) (6)

(1) TOLERANCE

- D = ±0.5%
- F = ±1%
- J = ±5% (for Jumper ordering, use code of J)

(2) PACKAGING TYPE

R = Paper / PE taping reel

(3) TEMPERATURE COEFFICIENT OF RESISTANCE

- = Based on spec.

(4) TAPING REEL

- 07 = 7 inch dia. Reel
- 7C = 7 inch dia. Reel, 1.5 x Standard Quantity
- 7D = 7 inch dia. Reel, 2 x Standard Quantity
- 13 = 13 inch dia. Reel

(5) RESISTANCE VALUE

There are 2~4 digits indicated the resistance value. Letter R/K/M is decimal point, no need to mention the last zero after R/K/M, e.g.1K2, not 1K20.
 Detailed coding rules of resistance are shown in the table of "Resistance rule of global part number".

(6) DEFAULT CODE

Letter L is system default code for ordering only. (Note)

| Resistance rule of global part number | |
|---------------------------------------|--|
| Resistance code rule | Example |
| DI | DI = Dummy |
| OR | OR = Jumper |
| XRXX (1 to 9.76 Ω) | IR = 1 Ω IR5 = 1.5 Ω 9R76 = 9.76 Ω |
| XXRX (10 to 97.6 Ω) | I0R = 10 Ω 97R6 = 97.6 Ω |
| XXXXR (100 to 976 Ω) | I00R = 100 Ω |
| XKXX (1 to 9.76 KΩ) | IK = 1,000 Ω 9K76 = 9760 Ω |
| XMXX (1 to 9.76 MΩ) | IM = 1,000,000 Ω 9M76 = 9,760,000 Ω |

ORDERING EXAMPLE

The ordering code of a RC0201 chip resistor, value 56 Ω with ±1% tolerance, supplied in 7-inch tape of 15,000 units per reel is: RC0201FR-7C56RL.

NOTE

1. All our RSMD products meet RoHS compliant and Halogen Free. "LFP" of the internal 2D reel label mentions "Lead Free Process".
2. On customized label, "LFP" or specific symbol can be printed.

PHYCOMP BRAND ordering codes

Both GLOBAL PART NUMBER (preferred) and I2NC (traditional) codes are acceptable to order Phycomp brand products.

GLOBAL PART NUMBER (PREFERRED)

For detailed information of GLOBAL PART NUMBER and ordering example, please refer to page 2.

I2NC CODE

| TYPE/ 0201 | 2322 | TOL. (%) | XXX | XXXXX | L | PAPER / PE TAPE ON REEL (units) ⁽²⁾ | | |
|---------------|------|-------------|-----|-------|-----|--|-----------|-----------|
| | (1) | | (2) | (3) | (4) | 10,000 | 20,000 | 50,000 |
| RC41 | 2322 | ±5% | 1 | to 1 | MΩ | 803 70xxx | 806 80xxx | 803 60xxx |
| RC42 | 2322 | ±1% | 1 | to 1 | MΩ | 806 7xxxx | 806 8xxxx | 806 6xxxx |
| Jumper | 2322 | - | 0 | Ω | | 803 91001 | --- | --- |
| Dummy | 2322 | - | - | | | 803 93001 | --- | --- |

| Resistance decade ⁽³⁾ | Last digit |
|----------------------------------|------------|
| 0.01 to 0.0976 Ω | 0 |
| 0.1 to 0.976 Ω | 7 |
| 1 to 9.76 Ω | 8 |
| 10 to 97.6 Ω | 9 |
| 100 to 976 Ω | 1 |
| 1 to 9.76 KΩ | 2 |
| 10 to 97.6 KΩ | 3 |
| 100 to 976 KΩ | 4 |
| 1 to 9.76 MΩ | 5 |
| 10 to 97.6 MΩ | 6 |

- (1) The resistors have a 12-digit ordering code starting with 2322.
- (2) The subsequent 4 or 5 digits indicate the resistor tolerance and packaging.
- (3) The remaining 4 or 3 digits represent the resistance value with the last digit indicating the multiplier as shown in the table of "Last digit of I2NC".
- (4) Letter L is system default code for order only. ^(Note)

Example:

| | | |
|--------|---|-------------|
| 0.02 Ω | = | 0200 or 200 |
| 0.3 Ω | = | 3007 or 307 |
| 1 Ω | = | 1008 or 108 |
| 33 KΩ | = | 3303 or 333 |
| 10 MΩ | = | 1006 or 106 |

ORDERING EXAMPLE

The ordering code of a RC42 resistor, value 56 Ω with ±1% tolerance, supplied in tape of 10,000 units per reel is: 232280675609L or RC0201FR-0756RL.

NOTE

- 1. All our RSMD products meet RoHS compliant and Halogen Free. "LFP" of the internal 2D reel label mentions "Lead Free Process".
- 2. On customized label, "LFP" or specific symbol can be printed.

MARKING

RC0201

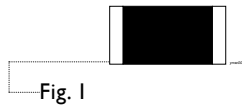

No marking

For further marking information, please refer to data sheet “Chip resistors marking”.

CONSTRUCTION

The resistor is constructed on top of a high-grade ceramic body. Internal metal electrodes are added on each end to make the contacts to the thick film resistive element. The composition of the resistive element is a noble metal imbedded into a glass and covered by a second glass to prevent environment influences. The resistor is laser trimmed to the rated resistance value. The resistor is covered with a protective epoxy coat, finally the two external terminations (matte tin on Ni-barrier) are added, as shown in Fig.2.

OUTLINES

For dimension, please refer to Table I

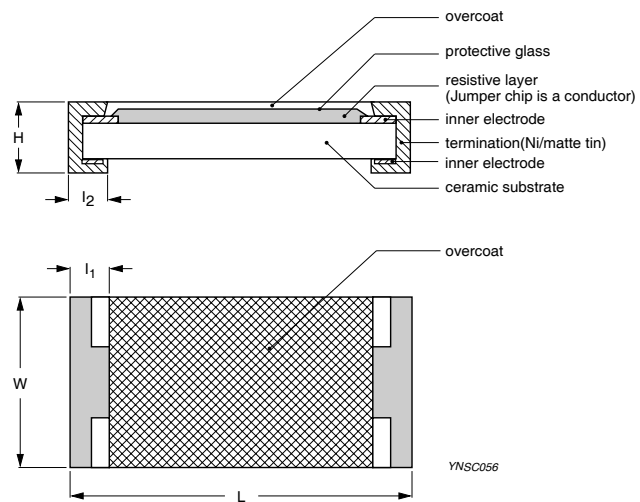

Fig. 2 Chip resistor outlines

DIMENSIONS

Table I

| TYPE | RC0201 |
|---------------------|------------|
| L (mm) | 0.60 ±0.03 |
| W (mm) | 0.30 ±0.03 |
| H (mm) | 0.23 ±0.03 |
| l ₁ (mm) | 0.10 ±0.05 |
| l ₂ (mm) | 0.15 ±0.05 |

ELECTRICAL CHARACTERISTICS

Table 2

| CHARACTERISTICS | RC0201 1/20 W |
|---------------------------------|---------------------------------|
| Operating Temperature Range | -55 °C to +125 °C |
| Maximum Working Voltage | 25 V |
| Maximum Overload Voltage | 50 V |
| Dielectric Withstanding Voltage | 50 V |
| Resistance Range | 5% (E24) 1 Ω to 10 MΩ |
| | 1% (E24/E96) 1 Ω to 10 MΩ |
| | 0.5% (E24/E96) 10 Ω to 1 MΩ |
| | Jumper < 0.05 Ω |
| Temperature Coefficient | 1 Ω ≤ R ≤ 10 Ω -100/+350 ppm/°C |
| | 10 Ω < R ≤ 10 MΩ ±200 ppm/°C |
| Jumper Criteria | Rated Current 0.5 A |
| | Maximum Current 1.0 A |

FOOTPRINT AND SOLDERING PROFILES

For recommended footprint and soldering profiles, please refer to data sheet “Chip resistors mounting”.

PACKING STYLE AND PACKAGING QUANTITY

Table 3 Packing style and packaging quantity

| PRODUCT TYPE | PACKING STYLE | REEL DIMENSION | QUANTITY PER REEL |
|--------------|----------------------------|----------------|----------------------------|
| RC0201 | Paper / PE Taping Reel (R) | 7" (178 mm) | 10,000/15,000/20,000 units |
| | | 13" (330 mm) | 50,000 units |

NOTE

1. For paper/PE tape and reel specification/dimensions, please refer to data sheet “Chip resistors packing”.
2. For size of 0201, standard quantity is 10,000 units per reel.

FUNCTIONAL DESCRIPTION

POWER RATING

RC0201 rated power at 70°C is 1/20 W

RATED VOLTAGE

The DC or AC (rms) continuous working voltage corresponding to the rated power is determined by the following formula:

$$V = \sqrt{P \times R}$$

or max. working voltage whichever is less

Where

$$V = \text{Continuous rated DC or AC (rms) working voltage (V)}$$

$$P = \text{Rated power (W)}$$

$$R = \text{Resistance value (Ω)}$$

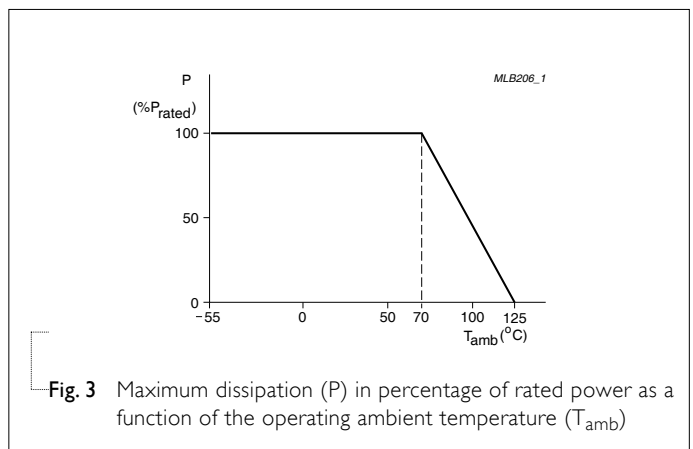

Fig. 3 Maximum dissipation (P) in percentage of rated power as a function of the operating ambient temperature (T_{amb})

TESTS AND REQUIREMENTS
Table 4 Test condition, procedure and requirements

| TEST | TEST METHOD | PROCEDURE | REQUIREMENTS |
|---|--------------------------|--|--|
| Temperature Coefficient of Resistance (T.C.R.) | IEC 60115-1 4.8 | At +25/-55 °C and +25/+125 °C Formula: $T.C.R = \frac{R_2 - R_1}{R_1(t_2 - t_1)} \times 10^6 \text{ (ppm/°C)}$ Where t ₁ =+25 °C or specified room temperature t ₂ =-55 °C or +125 °C test temperature R ₁ =resistance at reference temperature in ohms R ₂ =resistance at test temperature in ohms | Refer to table 2 |
| Life/Endurance | IEC 60115-1 4.25.1 | At 70±5 °C for 1,000 hours, RCWV applied for 1.5 hours on, 0.5 hour off, still air required | ±(1.0%+0.05 Ω) for 1%, 0.5% tol. ±(3.0%+0.05 Ω) for 5% tol. <100 mΩ for Jumper |
| High Temperature Exposure/Endurance at Upper Category Temperature | IEC 60068-2-2 | 1,000 hours at 125±5 °C, unpowered | ±(1.0%+0.05 Ω) for 1%, 0.5% tol. ±(2.0%+0.05 Ω) for 5% tol. <50 mΩ for Jumper |
| Moisture Resistance | MIL-STD-202G Method-106G | Each temperature / humidity cycle is defined at 8 hours, 3 cycles / 24 hours for 10d. with 25 °C / 65 °C 95% R.H, without steps 7a & 7b, unpowered Parts mounted on test-boards, without condensation on parts Measurement at 24±2 hours after test conclusion | ±(0.5%+0.05 Ω) for 1%, 0.5% tol. ±(2.0%+0.05 Ω) for 5% tol. <100 mΩ for Jumper |
| Thermal Shock | MIL-STD-202G Method-107G | -55/+125 °C Number of cycles required is 300. Devices unmounted Maximum transfer time is 20 seconds. Dwell time is 15 minutes. Air – Air | ±(0.5%+0.05 Ω) for 1%, 0.5% tol. ±(1%+0.05 Ω) for 5% tol. <50 mΩ for Jumper |

| TEST | TEST METHOD | PROCEDURE | REQUIREMENTS | | | | | | | | | | | | | | |
|------------------------------------|----------------------|---|---|-----------------|--------------|------------------|---------------------------|---------------------------------|-------|---------------------------------|-------|-----------------------------------|-------|----------------------------------|-------|------------------------------------|-------|
| Short Time Overload | IEC60115-1 4.13 | 2.5 times of rated voltage or maximum overload voltage whichever is less for 5 sec at room temperature | $\pm(1.0\%+0.05 \Omega)$ for 1%, 0.5% tol. $\pm(2.0\%+0.05 \Omega)$ for 5% tol. <50 m Ω for Jumper No visible damage | | | | | | | | | | | | | | |
| Board Flex/Bending | IEC 60068-2-21 | Chips mounted on a 90mm glass epoxy resin PCB (FR4) 5 mm bending Bending time: 60 \pm 5 seconds | $\pm(1.0\%+0.05 \Omega)$ <50 m Ω for Jumper No visible damage | | | | | | | | | | | | | | |
| Low Temperature Operation | IEC 60068-2-1 | The resistor shall be subjected to a DC rated voltage for 1.5 h-on, 0.5 h-off, at -55 \pm 3 °C This constitutes shall be repeated for 96 hours However the applied voltage shall not exceed the maximum operating voltage | $\pm(0.5\%+0.05 \Omega)$ for 1%, 0.5% tol. $\pm(1.0\%+0.05 \Omega)$ for 5% tol. No visible damage | | | | | | | | | | | | | | |
| Insulation Resistance | IEC 60115-1 4.6 | Rated continuous overload voltage (RCOV) for 1 minute <table border="1" style="margin-left: 20px;"> <tr> <td>Type</td> <td>RC0201</td> </tr> <tr> <td>Voltage (DC)</td> <td>50 V</td> </tr> </table> | Type | RC0201 | Voltage (DC) | 50 V | $\geq 10 G\Omega$ | | | | | | | | | | |
| Type | RC0201 | | | | | | | | | | | | | | | | |
| Voltage (DC) | 50 V | | | | | | | | | | | | | | | | |
| Dielectric Withstand Voltage | IEC 60115-1 4.7 | Maximum voltage (V_{rms}) applied for 1 minute <table border="1" style="margin-left: 20px;"> <tr> <td>Type</td> <td>RC0201</td> </tr> <tr> <td>Voltage (AC)</td> <td>50 V_{rms}</td> </tr> </table> | Type | RC0201 | Voltage (AC) | 50 V_{rms} | No breakdown or flashover | | | | | | | | | | |
| Type | RC0201 | | | | | | | | | | | | | | | | |
| Voltage (AC) | 50 V_{rms} | | | | | | | | | | | | | | | | |
| Resistance to Solvent | IPC/JEDEC J-STD-020D | Isopropylalcohol (C ₃ H ₇ OH) followed by brushing | No smeared | | | | | | | | | | | | | | |
| Noise | IEC 60115-1 4.12 | Maximum voltage (V_{rms}) applied | <table border="1" style="margin-left: 20px;"> <thead> <tr> <th>Resistors range</th> <th>Value</th> </tr> </thead> <tbody> <tr> <td>$R < 100 \Omega$</td> <td>10 dB</td> </tr> <tr> <td>$100 \Omega \leq R < 1 K\Omega$</td> <td>20 dB</td> </tr> <tr> <td>$1 K\Omega \leq R < 10 K\Omega$</td> <td>30 dB</td> </tr> <tr> <td>$10 K\Omega \leq R < 100 K\Omega$</td> <td>40 dB</td> </tr> <tr> <td>$100 K\Omega \leq R < 1 M\Omega$</td> <td>46 dB</td> </tr> <tr> <td>$1 M\Omega \leq R \leq 22 M\Omega$</td> <td>48 dB</td> </tr> </tbody> </table> | Resistors range | Value | $R < 100 \Omega$ | 10 dB | $100 \Omega \leq R < 1 K\Omega$ | 20 dB | $1 K\Omega \leq R < 10 K\Omega$ | 30 dB | $10 K\Omega \leq R < 100 K\Omega$ | 40 dB | $100 K\Omega \leq R < 1 M\Omega$ | 46 dB | $1 M\Omega \leq R \leq 22 M\Omega$ | 48 dB |
| Resistors range | Value | | | | | | | | | | | | | | | | |
| $R < 100 \Omega$ | 10 dB | | | | | | | | | | | | | | | | |
| $100 \Omega \leq R < 1 K\Omega$ | 20 dB | | | | | | | | | | | | | | | | |
| $1 K\Omega \leq R < 10 K\Omega$ | 30 dB | | | | | | | | | | | | | | | | |
| $10 K\Omega \leq R < 100 K\Omega$ | 40 dB | | | | | | | | | | | | | | | | |
| $100 K\Omega \leq R < 1 M\Omega$ | 46 dB | | | | | | | | | | | | | | | | |
| $1 M\Omega \leq R \leq 22 M\Omega$ | 48 dB | | | | | | | | | | | | | | | | |

| TEST | TEST METHOD | PROCEDURE | REQUIREMENTS |
|--------------------------------|-----------------------------|--|--|
| Humidity | IEC 60115-1 4.21 | Steady state for 1000 hours at 40 °C / 95% R.H. RCWV applied for 1.5 hours on and 0.5 hour off | $\pm(1.0\%+0.05 \Omega)$ for 1%, 0.5% tol. $\pm(2.0\%+0.05 \Omega)$ for 5% tol. <100 m Ω for Jumper |
| Intermittent Overload | IEC 60115-1 4.39 | 2.5 times of rated voltage or maximum overload voltage whichever is less for 1 second on and 25 seconds off; total 10,000 cycles | $\pm(1.0\%+0.05 \Omega)$ for 1%, 0.5% tol. $\pm(2.0\%+0.05 \Omega)$ for 5% tol. <100 m Ω for Jumper |
| Solderability - Wetting | IPC/JEDEC J-STD-002B test B | Electrical Test not required Magnification 50X SMD conditions: 1 st step: method B, aging 4 hours at 155 °C dry heat 2 nd step: lead-free solder bath at 245 \pm 3 °C Dipping time: 3 \pm 0.5 seconds | Well tinned (\geq 95% covered) No visible damage |
| - Leaching | IPC/JEDEC J-STD-002B test D | Lead-free solder, 260 °C, 30 seconds immersion time | No visible damage |
| - Resistance to Soldering Heat | IEC 60068-2-58 | Condition B, no pre-heat of samples Lead-free solder, 260 °C, 10 seconds immersion time Procedure 2 for SMD: devices fluxed and cleaned with isopropanol | $\pm(0.5\%+0.05 \Omega)$ for 1%, 0.5% tol. $\pm(1.0\%+0.05 \Omega)$ for 5% tol. <50 m Ω for Jumper No visible damage |

REVISION HISTORY

| REVISION | DATE | CHANGE NOTIFICATION | DESCRIPTION |
|-----------|--------------|---------------------|--|
| Version 8 | May 02, 2011 | - | <ul style="list-style-type: none"> - Add $\pm 0.5\%$ tolerance for RC0201 - Add new taping reel code of 7 inch dia. reel with 1.5 x standard quantity (15,000 units per reel) - 10" taping reel removed |
| Version 7 | Jan 06, 2011 | - | <ul style="list-style-type: none"> - Typo updated |
| Version 6 | Apr 27, 2010 | - | <ul style="list-style-type: none"> - Updated test items and methods - Add new taping reel code of 7 inch dia. reel with double standard quantity (20,000 units per reel) |
| Version 5 | Nov 10, 2009 | - | <ul style="list-style-type: none"> - Test items and methods updated - Test requirements upgraded - Resistance range extend |
| Version 4 | Jul 15, 2008 | - | <ul style="list-style-type: none"> - Description of "Halogen Free Epoxy" added - Define global part number |
| Version 3 | Apr 25, 2007 | - | <ul style="list-style-type: none"> - New datasheet for 0201 thick film 1% and 5% with lead-free terminations - Replace the 0201 part of pdf files: Pu-RC0201_51_PbFree_L_2 and Yu-RC0201_51_PbFree_L_2 - Max. working voltage, resistance rage, and TCR updated - Tests and Requirements updated |
| Version 2 | Sep 03, 2004 | - | <ul style="list-style-type: none"> - New datasheet for 0201 thick film 1% and 5% with lead-free terminations - Replace the 0201 part of pdf files: RC41_5_4, RC42_1_1 - Test method and procedure updated - PE tape added (paper tape will be replaced by PE tape) |

“ Yageo reserves all the rights for revising the content of this datasheet without further notification, as long as the products itself are unchanged. Any product change will be announced by PCN.”