

# TS-SG-02-X.X Drawing

**Note: Screw needs to be calibrated for a specific torque.  
Use part numbers shown in the table below to order appropriate screw**

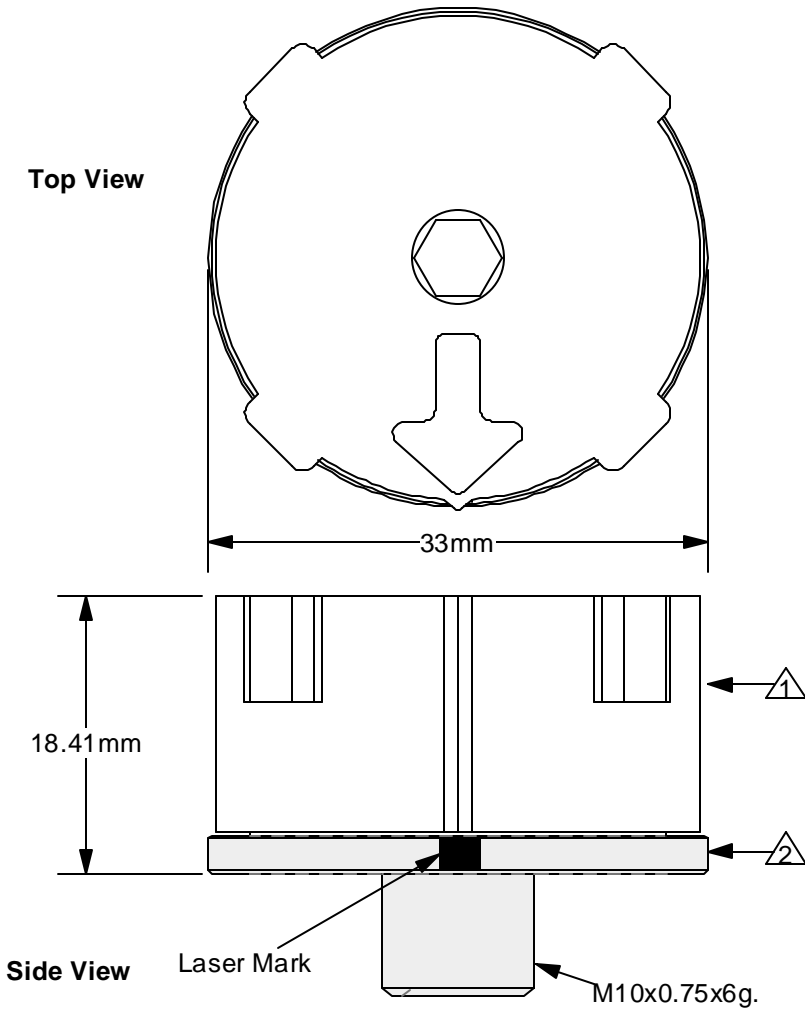

- ① Compression Screw Top: Clear anodized Aluminum.
- ② Compression Screw Bottom: Black anodized Aluminum M10 x0.75x6g Thread.

## Ordering Information

Part Number	Torque (in. lbs)
TS-SG-02-0.5	0.5
TS-SG-02-1.0	1.0
TS-SG-02-1.5	1.5
TS-SG-02-2.0	2.0
TS-SG-02-2.5	2.5
TS-SG-02-3.0	3.0
TS-SG-02-3.5	3.5
TS-SG-02-4.0	4.0
TS-SG-02-4.5	4.5
TS-SG-02-5.0	5.0

**Description: Torque Indicating Screw**  
Torque screw for 0.5 in lbs -5.2 in lbs

To be used with swivel lid sockets.  
Compression screw needs to be turned clockwise up to the point where the arrow on top of the compression screw aligns with laser mark on the compression screw bottom.

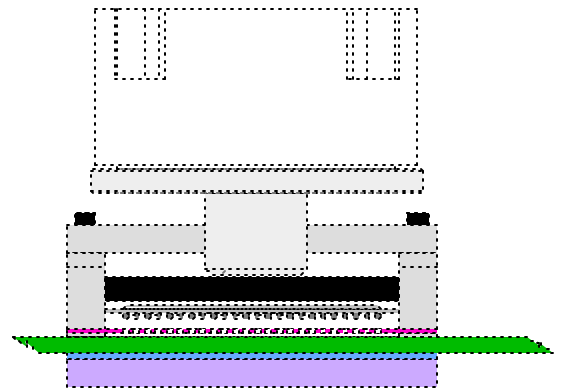

**Swivel lid socket with Torque Indicating Screw**

Tolerances: All tolerances are  $\pm 0.13\text{mm}$  [ $\pm 0.005$ " ] unless stated otherwise. Materials and specifications are subject to change without notice.

	<b>TS-SG-02-X.X Drawing</b>	Status: Released	Scale: 2:1	Rev: C
	© 2009 IRONWOOD ELECTRONICS, INC. Tele: (952) 229-8200 www.ironwoodelectronics.com	Drawing: Vinayak R		Date: 6/4/08
		File: TS-SG-02X_X Dwg	Modified: 10/21/09	