

# Ultra High Dynamic Range, Shutdown Monolithic Amplifier

## TSS-13HLN+

50Ω      1MHz to 1 GHz



CASE STYLE: DQ1225

### The Big Deal

- Ultra-High IP3, +42.9 dBm typ.
- Medium power, +28.4 dBm typ.
- Excellent Noise Figure, 1.4 dB typ.
- Shutdown feature

### Product Overview

TSS-13HLN+ (RoHS compliant) is an advanced wideband amplifier with shutdown feature. It is fabricated using E-PHEMT technology and offers extremely high dynamic range over a broad frequency range and with low noise figure. In addition, the TSS-13HLN+ has good input and output return loss over a broad frequency range. TSS-13HLN+ is enclosed in a 3mm x 3mm, 12-lead MCLP package and has very good thermal performance.

### Key Features

Feature	Advantages
Broad Band: 1MHz to 1GHz	Broadband covering primary wireless communications bands: VHF, UHF, Cellular
Extremely High IP3 40.6 dBm typical at 1 MHz 42.9 dBm typical at 0.5 GHz	The TSS-13HLN+ matches industry leading IP3 performance relative to device size and power consumption. The combination of the design and E-PHEMT Structure provides enhanced linearity over a broad frequency range as evidence in the IP3 being approximately 14-15 dB above the P1dB point. This feature makes this amplifier ideal for use in: <ul style="list-style-type: none"><li>• Driver amplifiers for complex waveform up converter paths</li><li>• Drivers in linearized transmit systems</li><li>• Secondary amplifiers in ultra-High Dynamic range receivers</li></ul>
Shutdown feature	Allow users to turn on and off the amplifier with pulsed signals while keeping the power supply at constant voltage to minimize DC power consumption
Low Noise Figure 1.4 dB at 0.5 GHz	Enables lower system noise figure performance and along with High OIP3 provides high dynamic range
High P1dB, 28.4 dBm at 0.5 GHz	High P1dB, High OIP3, Low NF results in a very dynamic range preventing amplifier saturation under strong interfering signals.



# Ultra High Dynamic Range, Shutdown Monolithic Amplifier

1 MHz to 1 GHz

## Product Features

- High IP3, 42.9 dBm typ. at 0.5 GHz
- Gain, 23 dB typ. at 0.5 GHz
- Low noise figure, 1.4 dB at 0.5 GHz
- High P1dB 28.4 dBm 0.5 GHz
- Shutdown feature

## Typical Applications

- Base station infrastructure
- CATV
- Cellular



## TSS-13HLN+

CASE STYLE: DQ1225

**+RoHS Compliant**

The +Suffix identifies RoHS Compliance. See our web site for RoHS Compliance methodologies and qualifications

## General Description

TSS-13HLN+ (RoHS compliant) is an advanced wideband amplifier with shutdown feature. It is fabricated using E-PHEMT technology and offers extremely high dynamic range over a broad frequency range and with low noise figure. In addition, the TSS-13HLN+ has good input and output return loss over a broad frequency range. TSS-13HLN+ is enclosed in a 3mm x 3mm, 12-lead MCLP package and has very good thermal performance.

### *simplified schematic and pad description*

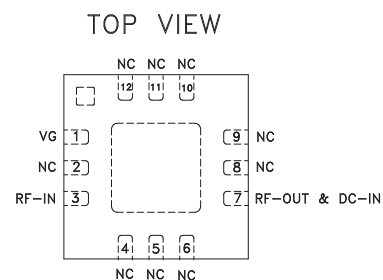
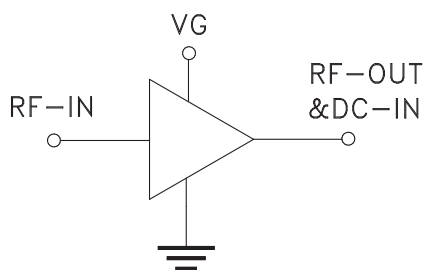

Function	Pin Number	Description
RF IN	3	RF Input
RF-OUT and DC-IN	7	RF Output and DC Bias
GND	Paddle	Connections to ground.
NC	2, 4-6, 8-12	No connection, grounded externally
VG	1	Control voltage for shutdown (VG)

**Electrical Specifications<sup>1</sup> at 25°C & 50Ω, unless noted**

Parameter	Condition (MHz)	Amplifier-ON			Amplifier-OFF	Units
		VDD = 8V			VDD = 8V	
		Min.	Typ.	Max.	Typ.	
Frequency Range		1		1000	1-1000	MHz
Noise Figure	1		3		—	dB
	20		1.4		—	
	250		1.3		—	
	500		1.4		—	
	1000		1.6		—	
Gain	1	22.4	25	27.4	-24	dB
	20	—	24.4	—	-22	
	250	20.8	23.2	25.4	-21	
	500	—	23	—	-22	
	1000	18.3	21.1	22.3	-26	
Reversed Isolation	1-1000		26		27	dB
Input Return Loss	1		11		12	dB
	20		16		12	
	250		17		12	
	500		20		12	
	1000		14		10	
Output Return Loss	1		11		1	dB
	20		19		2	
	250		18		2	
	500		33		2	
	1000		12		2	
Output Power @ 1dB compression AMP-ON	1		25.2		—	dBm
	20		26.7		—	
	250		28		—	
	500		28.4		—	
	1000		26.7		—	
Output IP3 (Pout = 0dBm/Tone)	1	—	40.6		—	dBm
	20	—	41.3		—	
	250	—	41.2		—	
	500	37.4	42.9		—	
	1000	—	40.8		—	
Device Operating Voltage (VDD)		7.6	8	8.4	8	V
Device Operating Current (ID)			234	241	7.5	mA
Control Voltage (VG)			0		5	V
DC Current (ID) Variation Vs. Temperature <sup>2</sup>			-136		—	uA/degC
DC Current(ID) Variation Vs. Voltage			0.025		—	mA/mV
Thermal Resistance			23.3		—	degC/W

1. Measured on Mini-Circuits Characterization test board TB-TSS-13HLN+. See Characterization Test Circuit (Fig. 1)

2. (Current at 95°C — Current at -45°C)/140

**Absolute Maximum Ratings<sup>3</sup>**

Parameter	Ratings
Operating Temperature (ground lead)	-40°C to 95°C
Storage Temperature	-65°C to 150°C
Total Power Dissipation	3.3W
Input Power	28 dBm (5 minutes max.) 10 dBm (continuous) for 1- 30 MHz 18 dBm (continuous) for 0.03-1 GHz
DC Voltage V <sub>DD</sub> <sup>4</sup> (Pad 7)	10V
DC Voltage V <sub>G</sub> <sup>5</sup> (Pad 1)	10V

<sup>3</sup> Permanent damage may occur if these limits are exceeded.

<sup>4</sup> Measured by keeping V<sub>G</sub>=0V.

<sup>5</sup> Measured by keeping V<sub>DD</sub>=8V.

**Control Voltage (V<sub>G</sub>) Fig. 1**

	Min.	Typ.	Max.	Units
Amplifier-ON	—	0	0.7	V
Amplifier-OFF	1.9	5	—	V

Switching Specifications

Parameter		Min.	Typ.	Max.	Units
Amplifier ON to Shutdown	OFF TIME (50% Control to 10% RF)	—	5.3	—	μs
	FALL TIME (90 to 10% RF)	—	7.3	—	
Amplifier Shutdown to ON	ON TIME (50% Control to 90% RF)	—	77.7	—	μs
	RISE TIME (10% to 90% RF)	—	54.2	—	
Control Voltage Leakage		—	633.3	—	mV

Characterization Test Circuit / Recommended Application Circuit

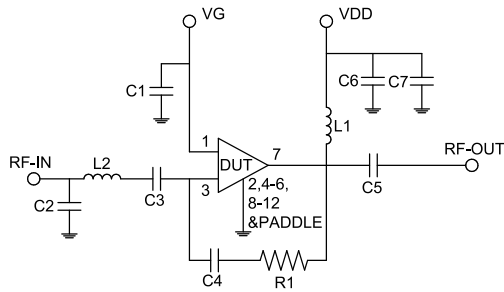

Component	Size	Value	Part Number	Manufacturer
C1	0402	0.1uF	GRM155R71C104KA88D	Murata
C2	0402	1.5pF	GRM1555C1H1R5CA1D	Murata
C3	0603	2.2uF	GRM188C71E225KE11D	Murata
C4	0402	0.1uF	GRM155R71C104KA88D	Murata
C5	0603	2.2uF	GRM188C71E225KE11D	Murata
C6	0402	1000pF	GRM1555C1H102JA01D	Murata
C7	0805	10uF	GRM21BC71E106KE11L	Murata
L1	1210	15uH	LQH32DN150K53L	Murata
L2	0603	5.1nH	0603CS-5N1XJLU	Coilcraft
R1	0402	1.5KOhm	RK73H1ETTP1501F	Koa

Fig 1. Block diagram of Test Circuit used for characterization. (DUT soldered on Mini-Circuits Characterization test board TB-TSS-13LN+) Gain, Return loss, Output power at 1dB compression (P1dB) , output IP3 (OIP3) and noise figure measured using Agilent’s N5242A PNA-X microwave network analyzer.

Conditions:

- Gain and Return Loss: Pin= -25dBm
- Output IP3 (OIP3): Two tones, spaced 1 MHz apart, +0dBm/tone at output.
- Switching Time  
 RF Signal: Pin=-25 dBm, f<sub>RF</sub>=500 MHz.  
 V<sub>DD</sub>=8V DC, V<sub>G</sub>=Pulse signal at 1 KHz with V<sub>HIGH</sub>=5V, V<sub>LOW</sub>=0V, 50% duty cycle.

Product Marking

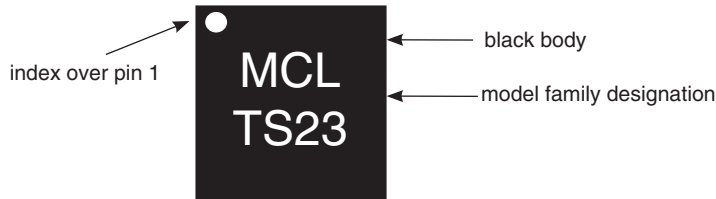

Marking may contain other features or characters for internal lot control

Additional Detailed Technical Information	
<i>additional information is available on our dash board. To access this information <a href="#">click here</a></i>	
<b>Performance Data</b>	Data Table
	Swept Graphs
	S-Parameter (S2P Files) Data Set (.zip file)
<b>Case Style</b>	DQ1225 <i>Plastic package, exposed paddle lead finish: Matte-Tin</i>
<b>Tape &amp; Reel</b> Standard quantities available on reel	F66 <i>7" reels with 20, 50, 100, 200, 500 or 1K devices</i>
<b>Suggested Layout for PCB Design</b>	PL-623
<b>Evaluation Board</b>	TB-TSS-13HLN+
<b>Environmental Ratings</b>	ENV08T9

**ESD Rating**

Human Body Model (HBM): Class 1A (Pass 250 V) in accordance with ANSI/ESD STM 5.1 - 2001

**MSL Test Flow Chart**

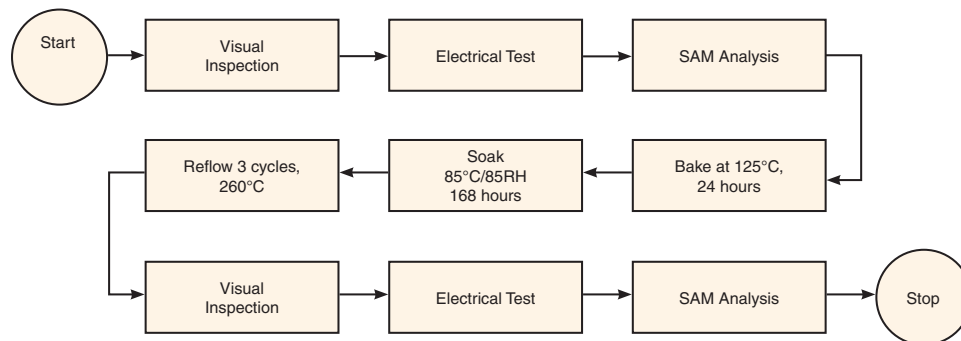

**Additional Notes**

- A. Performance and quality attributes and conditions not expressly stated in this specification document are intended to be excluded and do not form a part of this specification document.
- B. Electrical specifications and performance data contained in this specification document are based on Mini-Circuit's applicable established test performance criteria and measurement instructions.
- C. The parts covered by this specification document are subject to Mini-Circuits standard limited warranty and terms and conditions (collectively, "Standard Terms"); Purchasers of this part are entitled to the rights and benefits contained therein. For a full statement of the Standard Terms and the exclusive rights and remedies thereunder, please visit Mini-Circuits' website at [www.minicircuits.com/MCLStore/terms.jsp](http://www.minicircuits.com/MCLStore/terms.jsp)

