

# APPROVAL SHEET

**MM07N, MM04N, MM07O, MM04O**

**$\pm 1\%$ ,  $\pm 0.5\%$ ,  $\pm 0.25\%$ ,  $\pm 0.1\%$**

**TC50 , TC25**

Automotive Power Thin Film MELF  
Resistors

(Tantalum Nitride Thin Film MELF Resistor)

Size: 0207, 0204

AEC-Q200 Qualified



\*Contents in this sheet are subject to change without prior notice.

## FEATURE

1. High Reliability Tantalum Nitride Thin Film MELF Resistor.
2. AEC-Q200 qualified.
3. Products with lead free terminations meet RoHS requirements
4. Best in class pulse load capability
5. High power Rating up to 1W .
6. +/-0.1% is upon the customer request.

## APPLICATION

- Automotive electronics
- Medical equipment
- Measuring instrument
- Industrial.

## DESCRIPTION

The resistors are constructed in a high grade ceramic body (aluminum oxide), external metal electrodes are added at both end and connected by a resistive layer that is applied to the metallised rods. The composition of the resistive layer is adjusted to give the approximate resistance required and the value is trimmed to nominated value within tolerance which controlled by laser trimming of this resistive layer.

The resistive film is covered by epoxy molding compound designed for electrical, mechanical and climatic protection, and color code rings designate the resistance value.

Finally, the two external end terminations are added nickel plating and tin. For environmental soldering issue, the outer layer of these end terminations is a Lead-free solder .

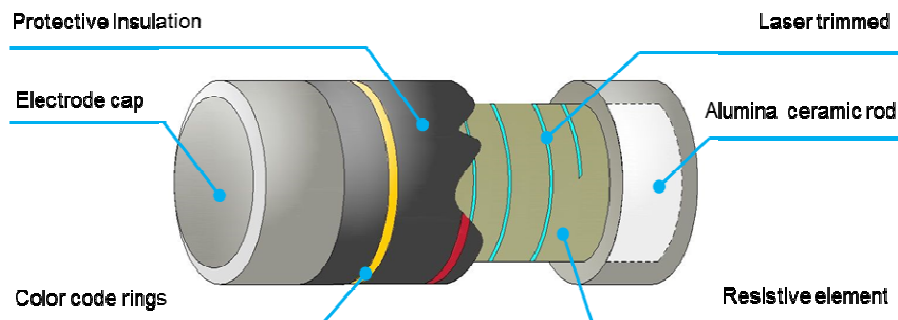

Fig 1. Construction of MELF

### QUICK REFERENCE DATA

Item	General Specification			
Series No.	MM07N	MM07O	MM04N	MM04O
Size code	0207 ( 6123 )		0204 ( 3715 )	
Resistance Tolerance	±1% ,±0.5% ,±0.25% ,±0.1%			
Resistance Range	11Ω ~ 100KΩ		10Ω ~ 50KΩ	
TCR (ppm/°C)	±50ppm/°C	±25ppm/°C	±50ppm/°C	±25ppm/°C
Max. dissipation at T <sub>amb</sub> =70°C	1W		2/5W	
Max. Operating Voltage (DC or RMS)	350V		200V	
Max. Overload Voltage (DC or RMS)	700V		400V	
Operating temperature	- 55 ~ +155 °C			

Note :

1. This is the maximum voltage that may be continuously supplied to the resistor element, see "IEC publication 60115-8"
2. Max. Operation Voltage : So called RCWV (Rated Continuous Working Voltage) is determined by

$$RCWV = \sqrt{\text{Rated Power} \times \text{Resistance Value}} \text{ or Max. RCWV listed above, whichever is lower.}$$

### DIMENSIONS:( unit:mm)

Type	0207	0204
L	5.90±0.20	3.50±0.10
D	2.20±0.10	1.40±0.15
K	1.40±0.10	0.90±0.10
Weight (g) 1000pcs	87.81	22.34

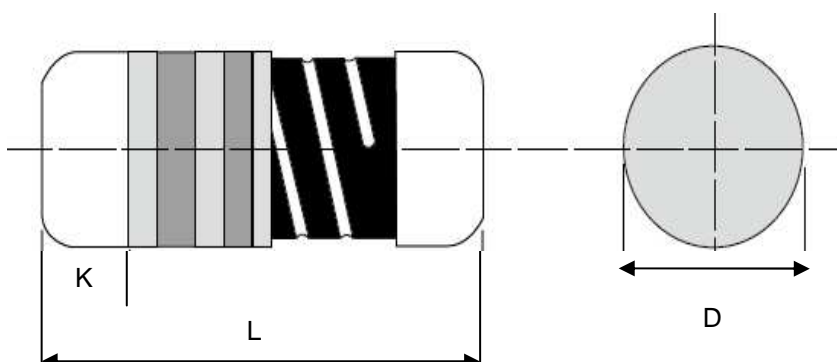

## FUNCTIONAL DESCRIPTION

### PRODUCT CHARACTERIZATION

Standard values of nominal resistance are taken from the E192 series for resistors with a tolerance of  $\pm 1\%$ ,  $\pm 0.5\%$ ,  $\pm 0.25\%$ ,  $\pm 0.1\%$ . The values of the E192 series are in accordance with "IEC publication 60063".

### DERATING

The power that the resistor can dissipate depends on the operating temperature; see Fig.2

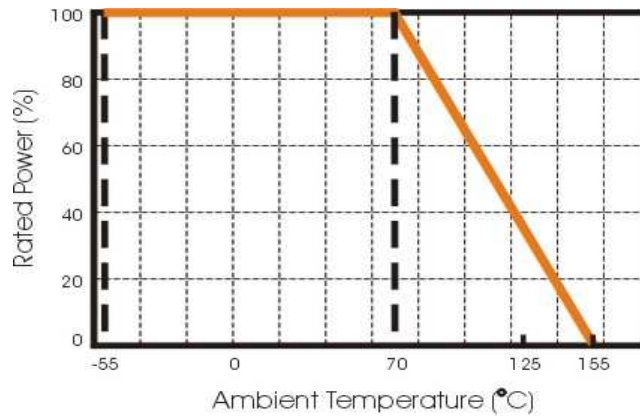

Fig.2 Maximum dissipation in percentage of rated power  
As a function of the ambient temperature

### MOUNTING

Due to their rectangular shapes and small tolerances, Surface Mountable Resistors are suitable for handling by automatic placement systems.

Cylindrical placement can be on ceramic rods and printed-circuit boards (PCBs).

Electrical connection to the circuit is by individual soldering condition.

The end terminations guarantee a reliable contact.

### RECOMMEND LAND PATTERN

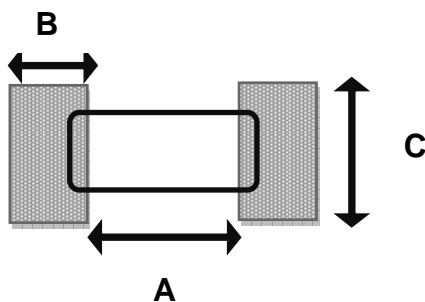

Type	0207	0204
A (mm)	3.0	1.6
B (mm)	1.7	1.2
C (mm)	2.4	1.6

## SOLDERING CONDITION

The robust construction of cylindrical resistors allows them to be completely immersed in a solder bath of 260°C for 10 seconds. Therefore, it is possible to mount Surface Mount Resistors on one side of a PCB and other discrete components on the reverse (mixed PCBs).

Surface Mount Resistors are tested for solderability at 235°C during 2 seconds within lead-free solder bath. The test condition for no leaching is 260°C for 30 seconds. Typical examples of soldering profile and condition that provide reliable joints without any damage are given in Fig 3. and Table 1.

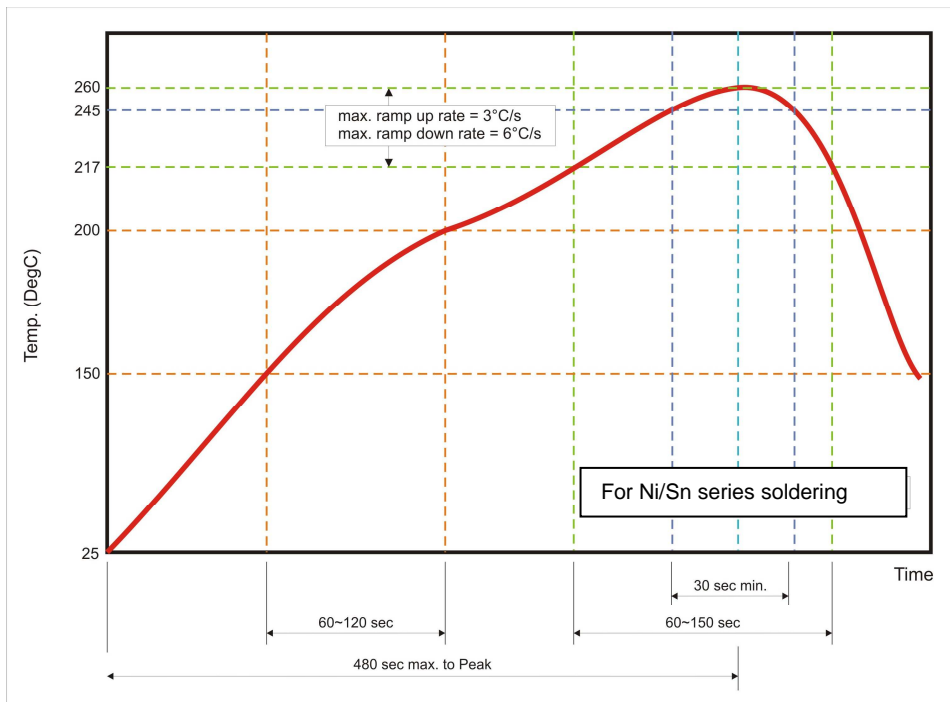

Fig. 3 Infrared soldering profile for MELF Resistors

Table 1. Infrared soldering condition for MELF Resistors

Temperature Condition	Exposure Time
Average ramp-up rate (217°C to 260°C)	Less than 3°C/second
Between 150 and 200°C	Between 60-120 seconds
> 217°C	Between 60-150 seconds
Peak Temperature	260°C +0/-5°C
Time within 245°C	Min. 30 seconds
Ramp-down rate (Peak to 217°C)	Less than 6°C/second
Time from 25°C to Peak	No greater than 480 seconds

## CATALOGUE NUMBERS

The resistors have a catalogue number starting with .

MM07	N	xxxx	B	T	L
<b>Size code</b>	<b>TCR</b>	<b>Resistance code</b>	<b>Tolerance</b>	<b>Packaging code</b>	<b>Termination code</b>
MM07: 0207	N: 50 ppm Power	102Ω =1020	F : ±1.0%	T: Taped & Reeled	L : Sn base
MM04: 0204	O: 25 ppm Power	37.4KΩ =3742	D : ±0.5%		(lead free)
		220Ω =2200	C : ±0.25%		
		20Ω =20R0	B : ±0.1%		
		0.1Ω =R100			
		0.033Ω =R033			

1. Reeled tape packaging: 12mm width plastic taping for MM07.
2. Reeled tape packaging: 8 mm width plastic taping for MM04.  
2,000pcs/reel for MM07.  
3,000pcs/reel for MM04.



## TEST AND REQUIREMENTS

TEST	PROCEDURE	REQUIREMENT
		Resistor
Electrical Characteristics <b>IEC 60115-1 4.8</b>	- DC resistance values measurement - Temperature Coefficient of Resistance (T.C.R) Natural resistance change per change in degree centigrade. $\frac{R_2 - R_1}{R_1(t_2 - t_1)} \times 10^6 \text{ (ppm/}^\circ\text{C)} \quad t_1 : 20^\circ\text{C}+5^\circ\text{C}-1^\circ\text{C}$ $R_1$ : Resistance at reference temperature (20°C+5°C/-1 °C) $R_2$ : Resistance at test temperature (-55°C or +125°C)	Within the specified tolerance
Short time overload (S.T.O.L) <b>IEC60115-1 4.13</b>	Permanent resistance change after a 5second application of a voltage 2.5 times RCWV or the maximum overload voltage specified in the above list, whichever is less.	$\Delta R/R$ max. $\pm(0.1\%+0.02\Omega)$
Resistance to soldering heat(R.S.H) <b>AEC- Q200-15</b>	Un-mounted chips completely immersed for 10±1second in a SAC solder bath at 260°C±5°C	no visible damage $\Delta R/R$ max. $\pm(0.1\%+0.02\Omega)$
Solderability <b>IEC-60115-1 4.17</b>	Un-mounted chips completely immersed for 2±0.5 second in a SAC solder bath at 235°C±5°C	good tinning (>95% covered) no visible damage
Thermal Shock <b>MIL-STD-202 Method 107</b>	Test -55 to 125°C/ dwell time 15min/ Max transfer time 20sec 1000 cycles	no visible damage $\Delta R/R$ max. $\pm(0.25\%+0.02\Omega)$
Bias Humidity <b>AEC- Q200-7</b>	1000 +48/-0 hours, loaded with 10% rated power in humidity chamber controller at +85°C/ 85%RH	$\Delta R/R$ max. $\pm(0.25\%+0.02\Omega)$
Load Life(Endurance) <b>IEC60115-1 4.25</b>	1000 +48/-0 hours, loaded with RCWV or Vmax in chamber controller 70 ±2°C, 1.5 hours on and 0.5 hours off	$\Delta R/R$ max. $\pm(0.20\%+0.02\Omega)$
Operational Life <b>AEC- Q200-8 MIL-STD-202 -108</b>	1000 hours at 125±2°C, loaded with rated power cont inuously	$\Delta R/R$ max. $\pm(0.25\%+0.02\Omega)$
High Temperature Exposure <b>AEC- Q200-3</b>	1000 hours @ 125°C, un-powered	$\Delta R/R$ max. $\pm(0.25\%+0.02\Omega)$
Moisture Resistance <b>AEC- Q200 -6 MIL-STD-202 Method 106</b>	65±2°C, 80~100% RH, 10 cycles, 24 hours/ cycle	$\Delta R/R$ max. $\pm(0.1\%+0.02\Omega)$
Mechanical Shock <b>MIL-STD-202 Method 213</b>	1/2 Sine Pulse / 1500g Peak / Velocity 15.4ft/sec	$\Delta R/R$ max. $\pm(0.1\%+0.02\Omega)$
Vibration <b>MIL-STD-202 Method 204</b>	5 g's for 20 min , 12 cycles each of 3 orientations	$\Delta R/R$ max. $\pm(0.1\%+0.02\Omega)$
Terminal strength <b>AEC- Q200-6</b>	1.8 kg for 60 s	No broken
Board flex <b>AEC- Q200-005</b>	Bending 2mm for 60 sec	$\Delta R/R$ max. $\pm(0.1\%+0.02\Omega)$

## PACKAGING

Paper Tape specifications (unit :mm)

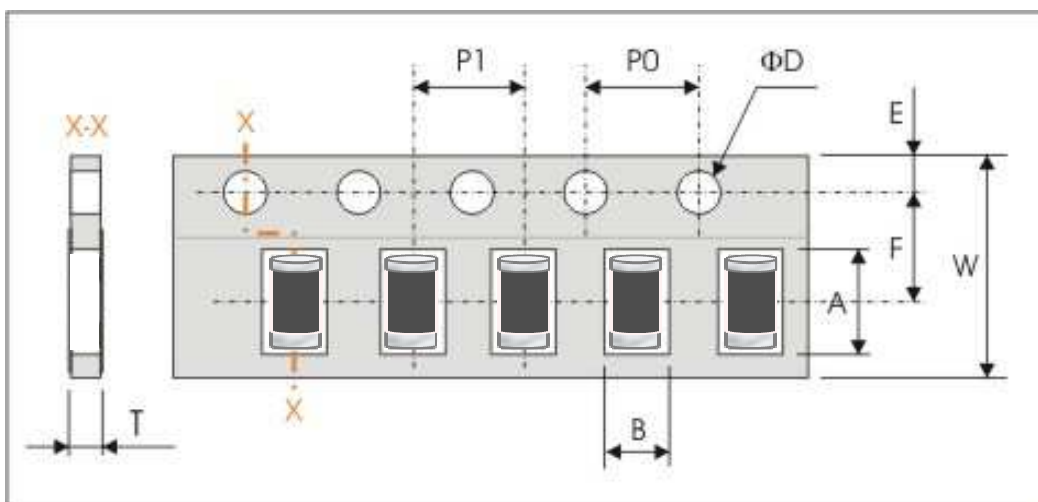

Series No.	A	B	W	E	F
MM07	6.15±0.10	2.40±0.10	12.0±0.10	1.75±0.10	5.50±0.05
MM04	3.65±0.10	1.555±0.10	0.80±0.10	1.75±0.10	3.50±0.05

Series No.	P0	P1	P2	ΦD0	T
MM07	4.00±0.10	4.00±0.10	2.00±0.05	1.50±0.05	1.80±0.1
MM04	4.00±0.10	4.00±0.10	2.00±0.05	1.50±0.05	2.70±0.1

### Reel dimensions

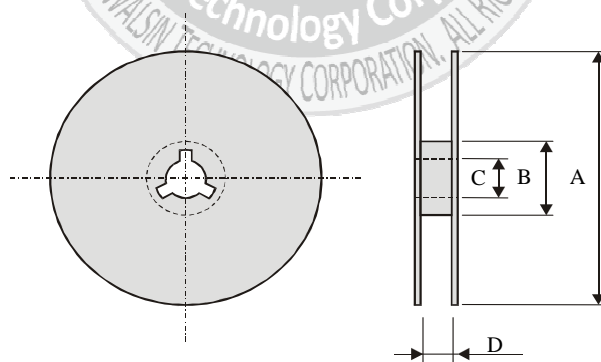

Symbol	A	B	C	D
0207	Φ178.0±2.0	Φ60.0±1.0	13.0±0.5	13.0±0.5
0204	Φ178.0±2.0	Φ60.0±1.0	13.0±0.2	9.0±0.5

### Taping quantity

- Cylinder resistors 2,000 pcs per reel ( MM07 )
- Cylinder resistors 3,000 pcs per reel ( MM04 )

**PULSE LOAD PERFORMANCE:**

**Single Pulse**

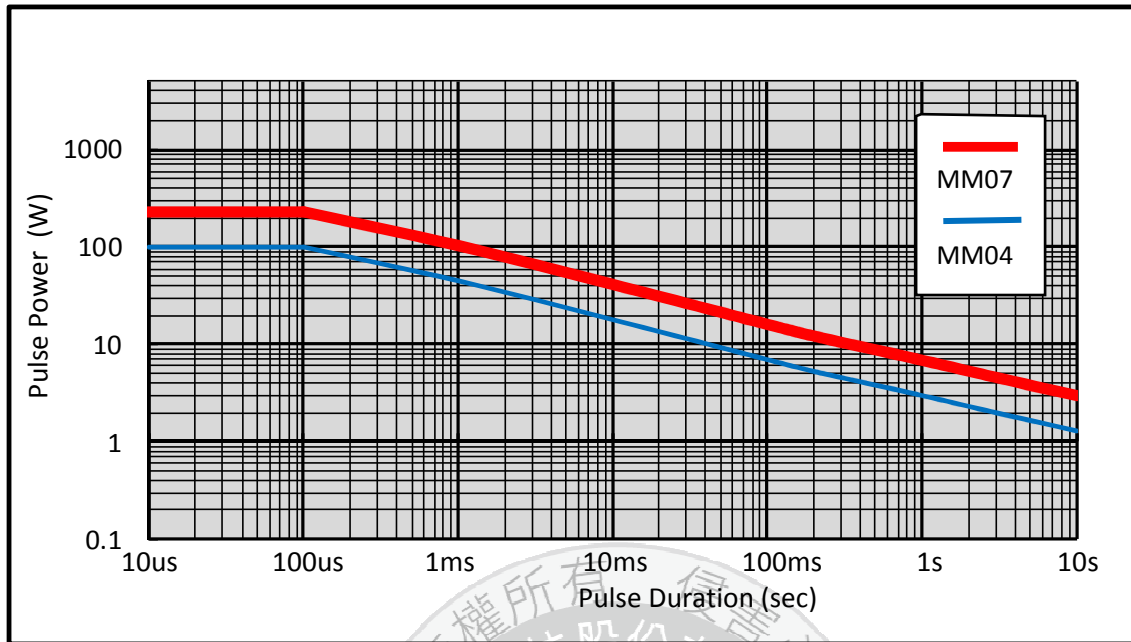

**Single Pulse for  $R \geq 10 \Omega$**

1000 rectangular pulse amplitudes are applied to the component at intervals of 60seconds, permissible the resistance to be varied by  $\pm (0.5\% R + 0.01\Omega)$ .

**Continuous Pulse :**

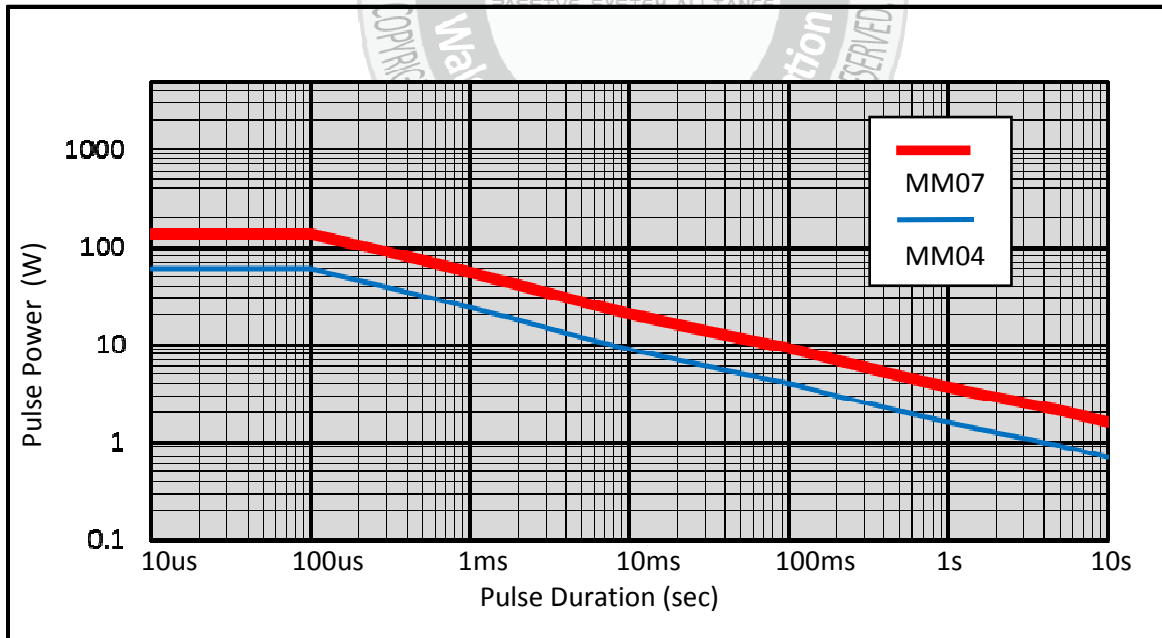

**Continuous Pulse for  $R \geq 10 \Omega$**

Continuous load is a pulse period generated by the repetitive rectangular pulse amplitude, the applied power dissipation is at a rated power of 70 °C. Permissible the resistance to be varied by  $\pm (0.5\% R + 0.01\Omega)$ .

**Pulse Voltage:**

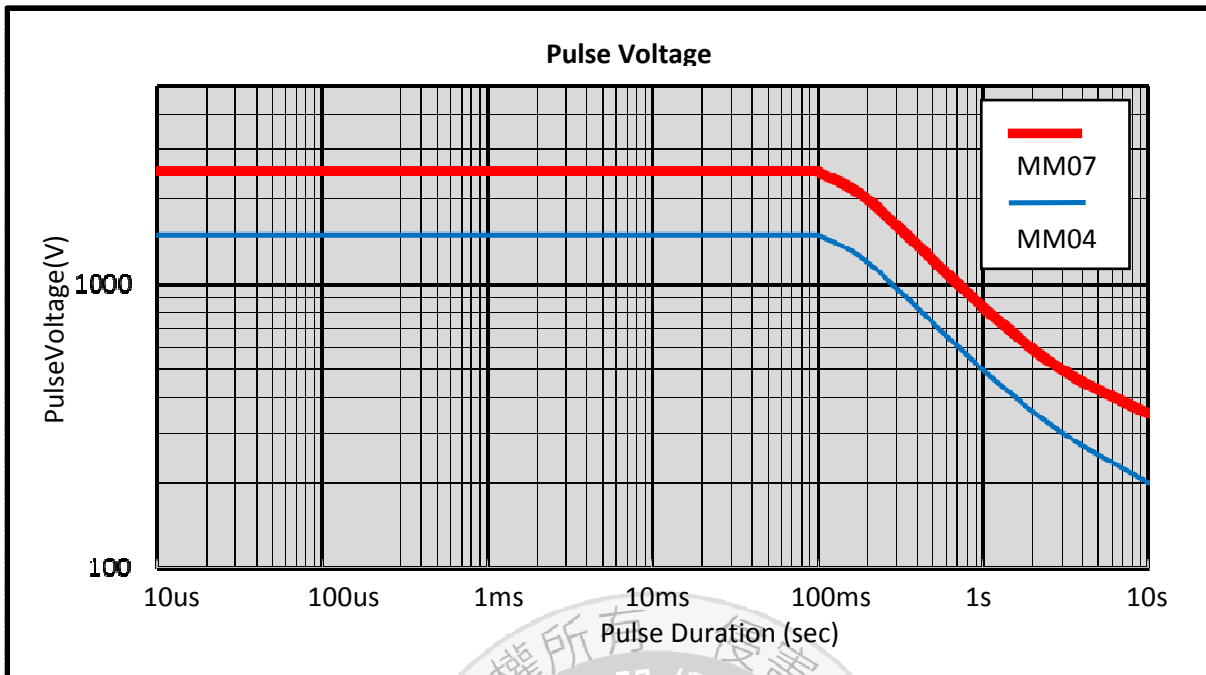

**Pulse Surge Overload :**

**1.2 / 50us Pulse**

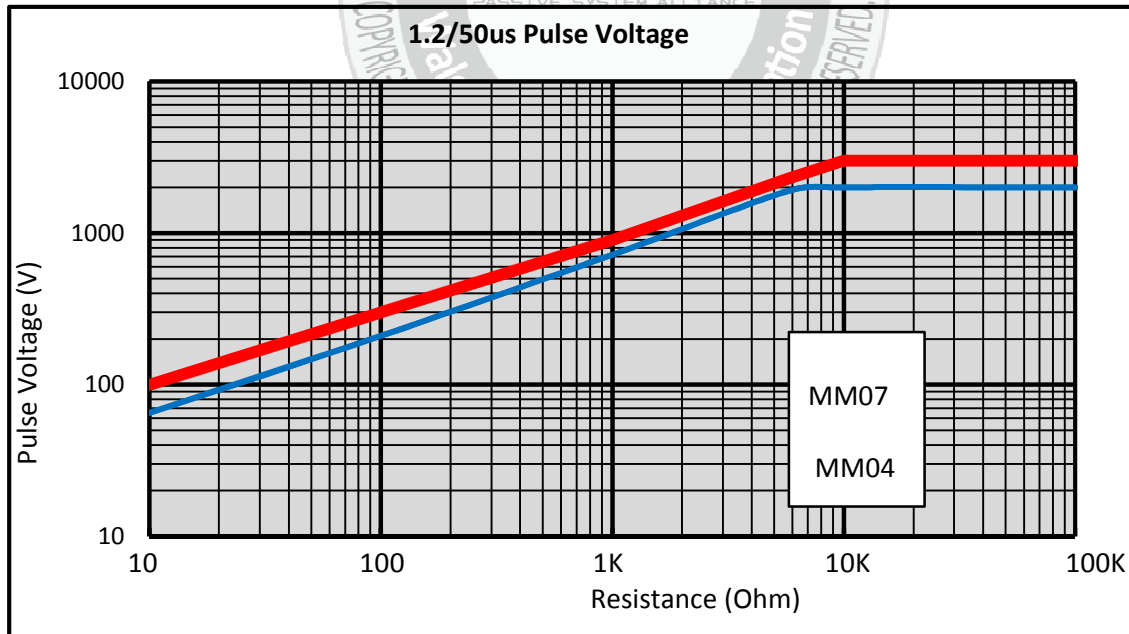

According to IEC 60115-1 4.27 1.2 / 50us use 5 pulses at 12sec intervals pulse shapes test resistor, permissible the resistance to be varied by  $\pm (0.5\% R + 0.01\Omega)$ .

### 10 / 700us Pulse

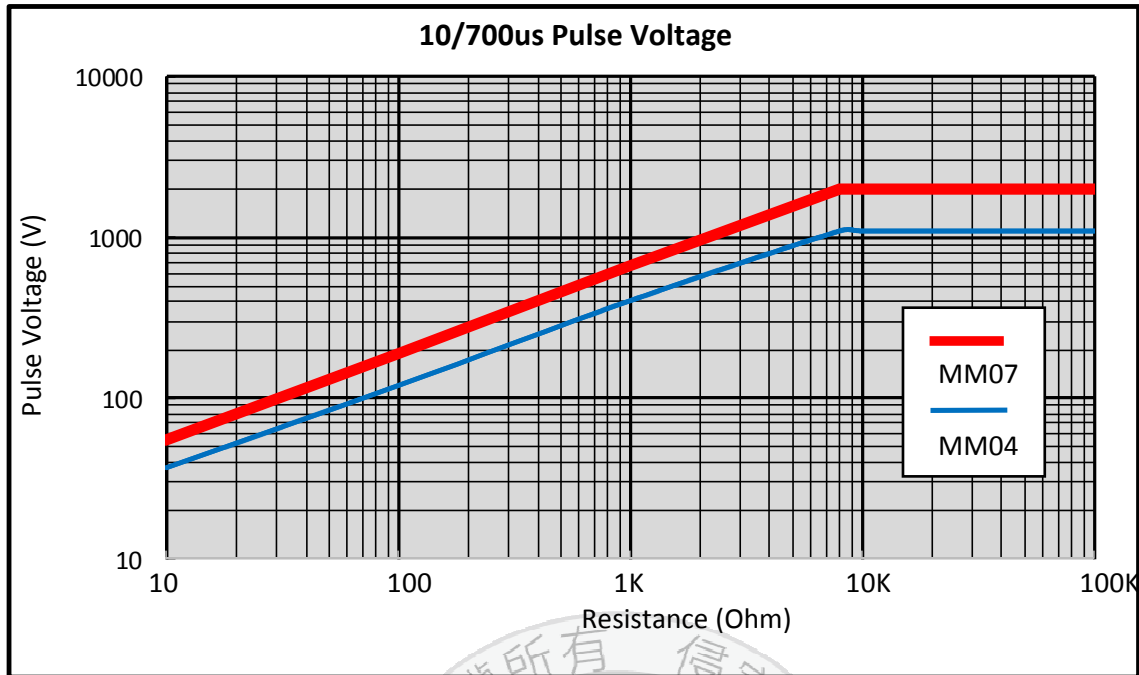

According to IEC 60115-1 4.27 10 / 700us use 10 pulses at 60sec intervals pulse shapes test resistor, permissible the resistance to be varied by  $\pm (0.5\% R + 0.01\Omega)$ .

