

Ideal for packaging printers requiring high reliability.

●Applications

Distribution / Food label printers
 Packaging printers
 Date-code printers

●Features

These thermal heads feature a near-edge structure based on the high-speed, high-quality, reliable step-free SE, SF series, enabling straight path for hand media or high speed printing

●External dimensions (Unit : mm)

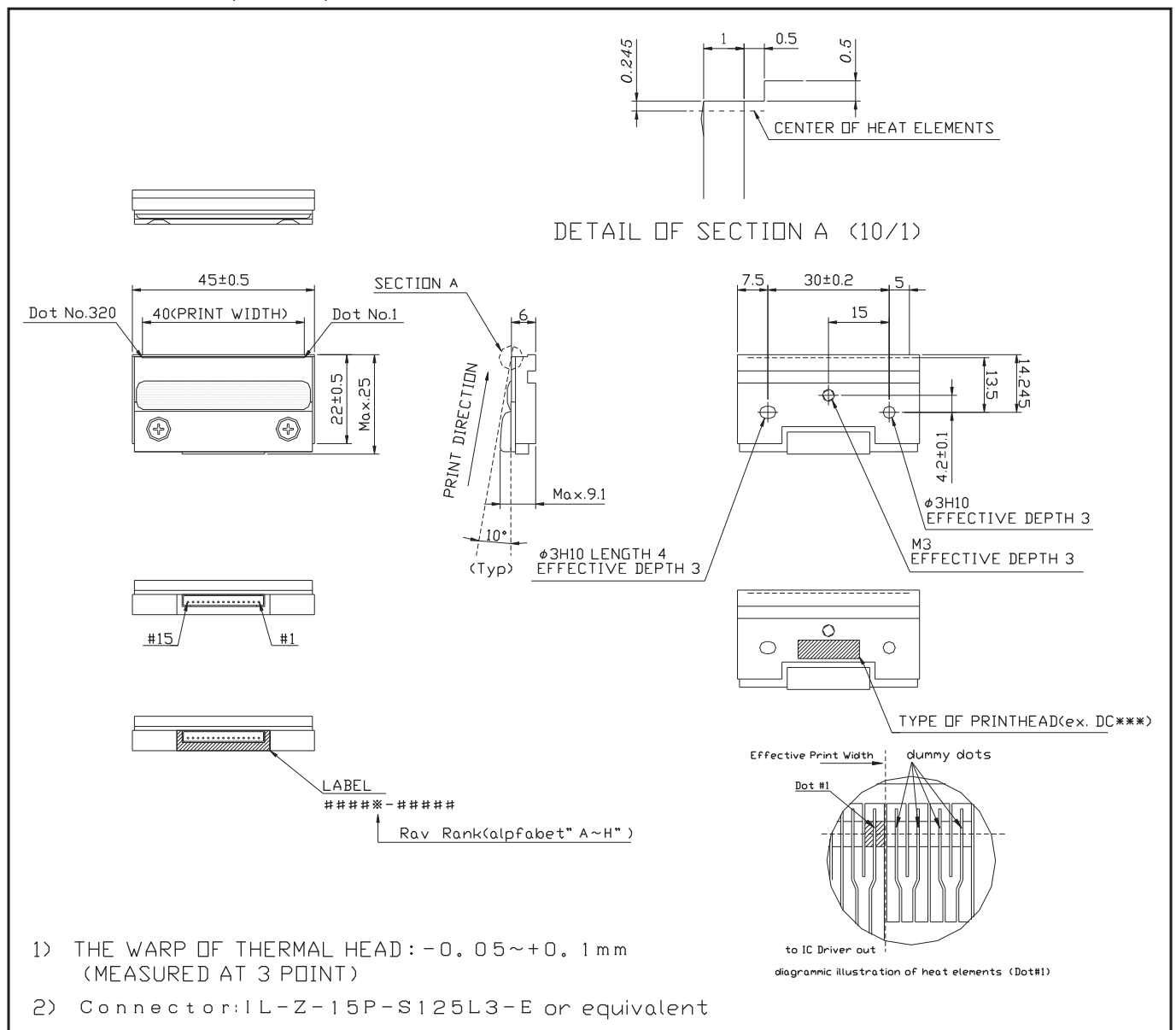

●Equivalent circuit

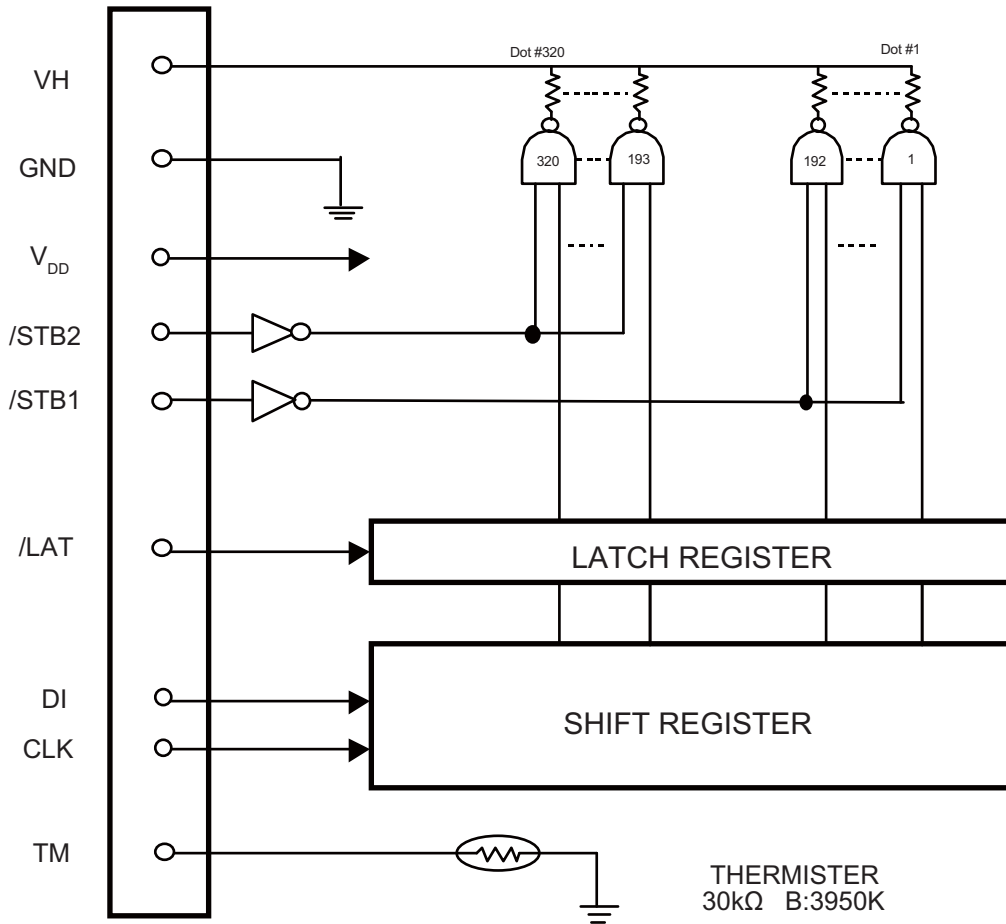

DI, STB DIVISION DOT No. CORRESPONDENCE

DI No.	DOT No.
DI	320 to 1

/STB No.	DOT No.
/STB 2	320 to 193
/STB 1	192 to 1

●Pin assignments

Connector A : IL-Z-15P-S125L3-E (JAE) or equivalent

No.	Circuit
1	V _H
2	V _H
3	/LAT
4	GND
5	GND
6	/STB1
7	V _{DD}
8	/STB2
9	TM
10	GND
11	GND
12	DI
13	CLK
14	V _H
15	V _H

Pin number : Refer to External dimensions

DI: Data In (Serial Input)

CLK : Clock Pulse(Max Transfer Frequency)

/LAT: Data Latch

TM: Thermistor

/STBn: Strobe

V_{DD} : Power Supply for Driver IC

N.C. : Non Connection

● Timing Chart

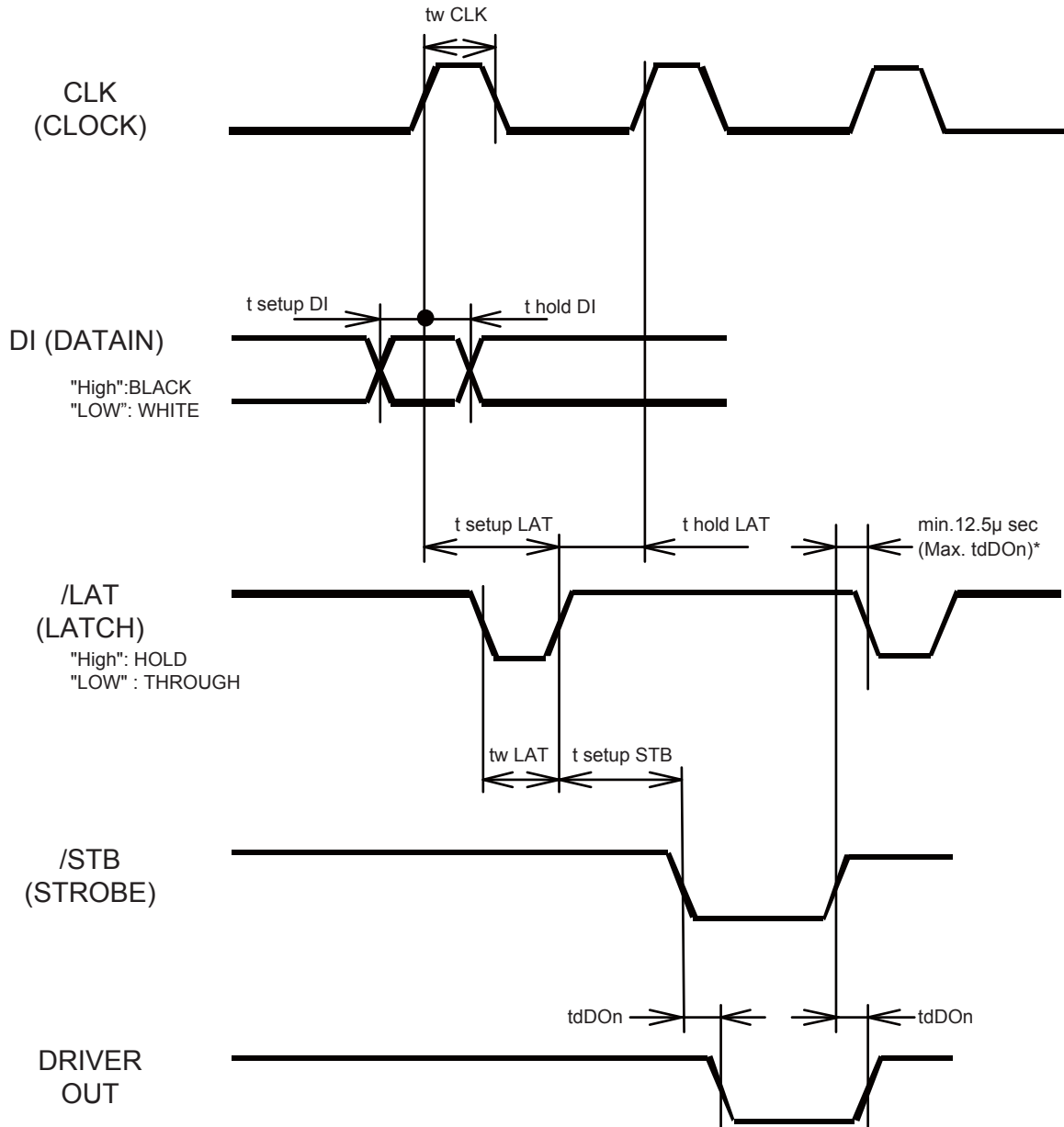

*If delay time for Driver Out can not be secured enough, there is a possibility that VH would fluctuate greatly. Please design the circuit so that VH does not exceed peak voltage (V_p).

●Characteristics

Parameter	symbol	Typical	Unit
Effective printing width	-	40	mm
Dot pitch	-	0.125	mm
Total dot number	-	320	dots
Average resistance value	R_{ave}	850	Ω
Applied voltage	V_H	12	V
Applied power	P_o	0.15	W/dot
Print cycle	SLT	2	ms/line
Pulse width	T_{ON}	1.5	ms
Maximum number of dots energized simultaneously	-	320	dots
Maximum clock frequency	-	10	MHz
Maximum platen diameter	-	∞	mm
Running life / pulse life	-	$50/1 \times 10^8$	Km/pulse
Operating temperature	-	5 to 45	$^{\circ}\text{C}$

Notes

- 1) The information contained herein is subject to change without notice.
- 2) Before you use our Products, please contact our sales representative and verify the latest specifications :
- 3) Although ROHM is continuously working to improve product reliability and quality, semiconductors can break down and malfunction due to various factors.
Therefore, in order to prevent personal injury or fire arising from failure, please take safety measures such as complying with the derating characteristics, implementing redundant and fire prevention designs, and utilizing backups and fail-safe procedures. ROHM shall have no responsibility for any damages arising out of the use of our Products beyond the rating specified by ROHM.
- 4) Examples of application circuits, circuit constants and any other information contained herein are provided only to illustrate the standard usage and operations of the Products. The peripheral conditions must be taken into account when designing circuits for mass production.
- 5) The technical information specified herein is intended only to show the typical functions of and examples of application circuits for the Products. ROHM does not grant you, explicitly or implicitly, any license to use or exercise intellectual property or other rights held by ROHM or any other parties. ROHM shall have no responsibility whatsoever for any dispute arising out of the use of such technical information.
- 6) The Products are intended for use in general electronic equipment (i.e. AV/OA devices, communication, consumer systems, gaming/entertainment sets) as well as the applications indicated in this document.
- 7) The Products specified in this document are not designed to be radiation tolerant.
- 8) For use of our Products in applications requiring a high degree of reliability (as exemplified below), please contact and consult with a ROHM representative : transportation equipment (i.e. cars, ships, trains), primary communication equipment, traffic lights, fire/crime prevention, safety equipment, medical systems, servers, solar cells, and power transmission systems.
- 9) Do not use our Products in applications requiring extremely high reliability, such as aerospace equipment, nuclear power control systems, and submarine repeaters.
- 10) ROHM shall have no responsibility for any damages or injury arising from non-compliance with the recommended usage conditions and specifications contained herein.
- 11) ROHM has used reasonable care to ensure the accuracy of the information contained in this document. However, ROHM does not warrants that such information is error-free, and ROHM shall have no responsibility for any damages arising from any inaccuracy or misprint of such information.
- 12) Please use the Products in accordance with any applicable environmental laws and regulations, such as the RoHS Directive. For more details, including RoHS compatibility, please contact a ROHM sales office. ROHM shall have no responsibility for any damages or losses resulting non-compliance with any applicable laws or regulations.
- 13) When providing our Products and technologies contained in this document to other countries, you must abide by the procedures and provisions stipulated in all applicable export laws and regulations, including without limitation the US Export Administration Regulations and the Foreign Exchange and Foreign Trade Act.
- 14) This document, in part or in whole, may not be reprinted or reproduced without prior consent of ROHM.



Thank you for your accessing to ROHM product informations.
More detail product informations and catalogs are available, please contact us.

ROHM Customer Support System

<http://www.rohm.com/contact/>