

Technical Data Sheet
Plastic Gear Analog Servo
Part No. LS-0006

1. Apply Environmental Condition

No.	Item	Specification
1-1	Storage Temperature Range	-20°C - 60°C
1-2	Operating Temperature Range	-10°C - 50°C
1-3	Operating Voltage Range	4.5V - 6.0V

2. Standard Test Environment

No.	Item	Specification
2-1	Standard Test Environment	Any test must be under normal temperature and humidity. Temperature: $25 \pm 5^{\circ}\text{C}$ Humidity: $65 \pm 10\%$, according to the standard to judge.

3. Appearance Inspection

No.	Item	Specification
3-1	Outline Drawing	21.5*11.8*22.7mm
3-2	Appearance	No damage

4. Electrical Specification (Function of the Performance)

No.	Item	4.8V	6.0V
4-1	Operating speed (at no load)	0.14 sec / 60°	0.12 sec / 60°
4-2	Running current (at no load)	120mA	140 mA
4-3	Stall torque (at locked)	1.0 kg-cm,	1.2 kg-cm
4-4	Stall current (at locked)	390 mA	460 mA
4-5	Idle current (at stopped)	4 mA	5 mA

5. Mechanical Specification

No.	Item	Specification
5-1	Overall Dimensions	21.5*11.8*22.7
5-2	Limit angle	180°± 10°
5-3	Weight	8 ± 1 g
5-4	Connector wire gauge	# 28 PVC
5-5	Connector wire length	150 ± 5 mm
5-6	Horn gear spline	24T/ψ 3.92
5-7	Horn type	Cross, disk, star
5-8	Reduction ratio	1/630

6. Control Specification

No.	Item	Specification
6-1	Control system	Change pulse width
6-2	Amplifier type	Analog control
6-3	Operating travel	90° (at 1000 → 2000 μsec)
6-4	Neutral position	1500 μsec
6-5	Dead band width	5 μsec
6-6	Rotating direction	anticlockwise (at 1500 → 2000 μsec)
6-7	Pulse width range	800 → 2200 μsec
6-8	Maximum travel	About 165° (at 800 → 2200 μsec)

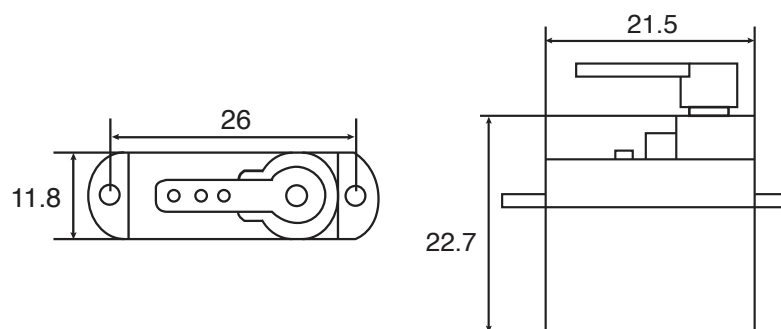

Leo Sales Ltd.

Richmond, BC, Canada | support@leosales.com